



# Guide on How to Develop a Small Hydropower Plant



The present document is an updated version developed by the Thematic Network on Small hydropower (TNSHP) of the Layman's Guidebook on how to develop a small hydro site, by Celso Penche1998.

This Guide has been translated by the TNSHP to German, French, and Swedish



## **INDEX**

Acknowledgements	i
Executive Summary	ii
Chapter 1. Introduction	1
Chapter 2. Fundamental of Hydraulic Engineering	12
Chapter 3. Evaluating Stream Flow	42
Chapter 4. Site Evaluation Methodologies	71
Chapter 5. Hydraulic Structures	91
Chapter 6. Electromechanical Equipment	152
Chapter 7. Environmental impact and its mitigation	199
Chapter 8. Economic analysis	236
Chapter 9. Administrative procedures	254
Glossary	290

## **ACKNOWLEDGEMENTS**

This Guide is an updated and adapted version of the publication “Layman’s Guidebook on How to Develop a Small Hydro Site”, published by ESHA - the European Small Hydropower Association – in 1998 in the frame of the European Commission DG-TREN (Directorate General for Transport and Energy) ALTENER programme.

Although based on the original, this guide has been entirely updated and adapted due to significant changes in the sector in the latest years as concern environmental and administrative aspects in particular. The updated version is available in English, French, German and Swedish what has added value to the already existing Spanish and Italian versions of the original publication.

The “Guide on how to develop a Small Hydro Site” has been carried out within the EC Project “Thematic Network on Small Hydropower”, financed by the Fifth RD&D Framework Programme (FP5). It has been updated and adapted by a Revision Committee under the coordination and guidelines of ESHA. Members of the Revision Committee include the project partners Francis Armand (ADEME), Anton Schleiss (EPFL-LCH), Erik Bollaert (EPFL-LCH), Pedro Manso (EPFL-LCH), Jochen Bard (ISET), Jamie O’Nians (IT Power), Vincent Denis (MHyLab), Bernhard Pelikan (ÖVFK), Jean-Pierre Corbet (SCPTH), Christer Söderberg (SERO), Jonas Rundqvist (SERO) and Luigi Papetti (Studio Frosio). The network thanks Steve Cryer (BHA) for his input.

Special thanks to Celso Penche (ESHA), author of the Layman’s Guide, who has revised the contents of the current Guide guaranteeing its consistency and accuracy.

## **EXECUTIVE SUMMARY**

Developing a small hydropower site is not a simple task. There are many aspects which have to be taken into consideration, covering many disciplines ranging from business, engineering, financial, legal and administration. These will all be necessary at the different development stages from, first choosing a site until the plant goes into operation.

The “Laymans Guide” guide brings together all of these aspects in a step-by-step approach, and will serve as a useful tool for a potential developer of a small hydropower scheme.

This guide is divided into nine chapters and covers the basic concepts, meaning of definitions and technological issues to be addressed.

**Chapter 1** – Introduces basic concepts, such as the definition of small hydropower, types of schemes, ways of exploiting the water resource available and gives a general overview of the guide’s contents,

**Chapters 2 through to 9** – describe the essential steps to be followed to evaluate a proposed scheme before deciding whether to proceed to a detailed feasibility study.

The basic concepts considered in the guide are:

- Topography and geomorphology of the site.
- Evaluation of the water resource and its generating potential.
- Site selection and basic layout.
- Hydraulic turbines and generators and their control.
- Environmental impact assessment and mitigation measures.
- Economic evaluation of the project and financing potential.
- Institutional framework and administrative procedures to obtain the necessary consents

Reading this guide will inform the potential small hydropower developer and give a better understanding of the different issues, phases and procedures that need be followed to develop and run a small hydropower operation.

Bernhard Pelikan

President ESHA

## **CHAPTER 1: INTRODUCTION**

### **CONTENTS**

1	INTRODUCTION .....	2
1.1	A free fuel resource potentially everlasting .....	2
1.2	Definition of small hydropower .....	3
1.3	Site configurations .....	3
1.3.1	Run-of-river schemes .....	3
1.3.2	Schemes with the powerhouse at the base of a dam .....	5
1.3.3	Schemes integrated within an irrigation canal .....	7
1.3.4	Schemes integrated in a water abstraction system .....	8
1.4	Planning a small hydropower scheme.....	8

### **LIST OF FIGURES**

Figure 1-1	High head scheme .....	4
Figure 1-2	Low head scheme with penstock.....	4
Figure 1-3	Low head scheme integrated in the dam .....	5
Figure 1-4	Low head scheme using an existing dam .....	6
Figure 1-5	Low head scheme – siphon intake .....	6
Figure 1-6	Integrated scheme using an irrigation canal.....	7
Figure 1-7	Elongated spillway scheme using an irrigation canal .....	7
Figure 1-8	Scheme integrated in a water supply system.....	8

# 1 INTRODUCTION<sup>i</sup>

## 1.1 A free fuel resource potentially everlasting.

Following the “Third Conference of the Parties to the United Nations Framework Convention on Climate Change” held in Kyoto in December 1997, the European Union has recognized the urgent need to tackle the climate change issue. It has also adopted a target to reduce greenhouse gas emissions by 8 % by 2010 from 1990 levels, whereas for other industrialised countries the target is 5 %.

To facilitate the Member States achieving this objective, the Commission identified a series of actions, focusing on reducing energy consumption and carbon emissions (CO<sub>2</sub>).

The development of energy from renewable resources is a very important step in the reduction of CO<sub>2</sub> emissions. Therefore the EU Council and Parliament has brought forward Directive 2001/77/EC for the promotion of electricity produced from renewable energy resources

Electricity production from hydropower has been, and still is today, the first renewable source used to generate electricity. Nowadays hydropower electricity in the European Union - both large and small scale – represents, according to the White Paper, 13% of the total electricity generated, so reducing the CO<sub>2</sub> emissions by more than 67 million tons a year. But whereas the conventional hydro requires the flooding of large areas of land, with its consequential environmental and social issues, the properly designed small hydro schemes are easily integrated into local ecosystems.

In 2001, approximately 365 TWh of hydro energy was produced in the European Union from an overall capacity of 118 GW. Small hydro plants accounted for 8.4% of installed capacity (9.9 GW) and produced 39 TWh (about 11% of Hydropower generation). Given a more favorable regulatory environment, the European Commission objective of 14000 MW by 2010 should be achievable and that small hydro would be the second largest contributor behind windpower.

The large majority of small hydro plants are “run-of-river” schemes, meaning that they have no or relatively small water storage capability. The turbine only produces power when the water is available and provided by the river.

When the river flow falls below some predetermined value, the generation ceases. Some plants are stand alone systems used in isolated sites, but in most cases in Europe, the electricity generated is connected to the grid. Stand-alone, small, independent schemes may not always be able to supply energy, unless their size is such that they can operate whatever the flow in the river is. In some cases, this problem can be overcome by using any existing lakes or reservoir storage that exists upstream, of the plant.

The connection to the grid has the advantage of easier control of the electrical system frequency of the electricity, but has the disadvantage of being tripped off the system due to problems outside of the plant operator’s control.

It is possible for grid connected systems to sell either all or some of their energy to supply company. (Note: this may not necessarily be the grid operator). However, the price paid for this energy is generally, in Europe particularly, fairly low. In recent years, supported by the RES-e

Directive and in some cases National Government legislation enhanced payments are available for trading renewable energy states. This has helped small scale developments obtain a reasonable rate of return on the investment. It has also led to an increase in small scale hydro schemes being developed.

## **1.2 Definition of small hydropower**

There is no consensus in EU member states on the definition of small hydropower: Some countries like Portugal, Spain, Ireland and now, Greece and Belgium, accept 10 MW as the upper limit for installed capacity. In Italy the limit is fixed at 3 MW (plants with larger installed power should sell their electricity at lower prices) and in Sweden 1.5 MW. In France the limit has been recently established at 12 MW, not as an explicit limit of SHP, but as the maximum value of installed power for which the grid has the obligation to buy electricity from renewable energy sources. In the UK 20MW is generally accepted as the threshold for small hydro. For the purposes of this text any scheme with an installed capacity of 10 MW or less will be considered as small. This figure is adopted by five member states, ESHA, the European Commission and UNIPED (International Union of Producers and Distributors of Electricity).

## **1.3 Site configurations**

The objective of a hydropower scheme is to convert the potential energy of a mass of water, flowing in a stream with a certain fall to the turbine (termed the "head"), into electric energy at the lower end of the scheme, where the powerhouse is located. The power output from the scheme is proportional to the flow and to the head.

Schemes are generally classified according to the "Head":

- High head: 100-m and above
- Medium head: 30 - 100 m
- Low head: 2 - 30 m

These ranges are not rigid but are merely means of categorizing sites.

Schemes can also be defined as:

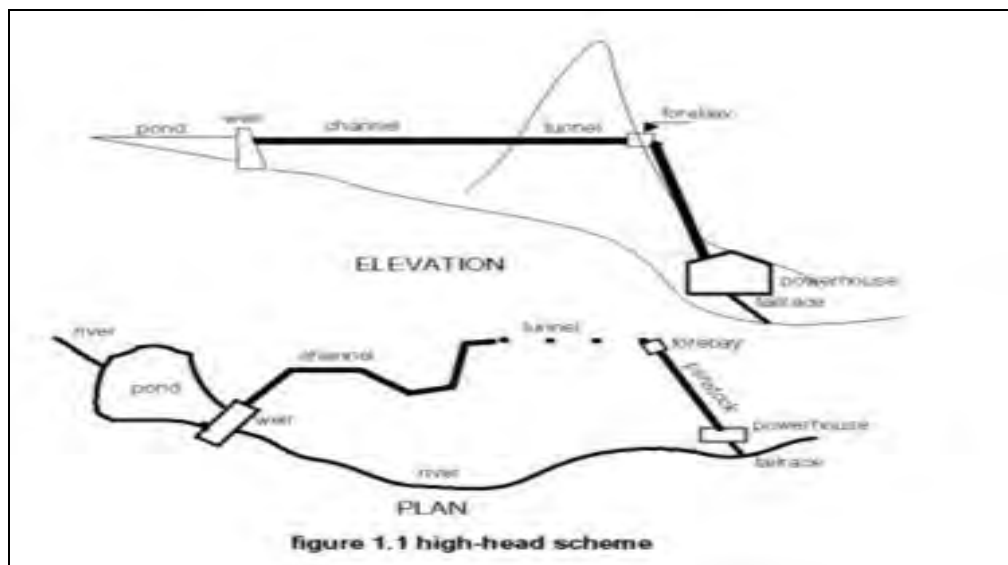
- Run-of-river schemes
- Schemes with the powerhouse located at the base of a dam
- Schemes integrated on a canal or in a water supply pipe

### **1.3.1 Run-of-river schemes**

Run-of-river schemes are where the turbine generates electricity as and when the water is available and provided by the river. When the river dries up and the flow falls below some predetermined amount or the minimum technical flow for the turbine, generation ceases.

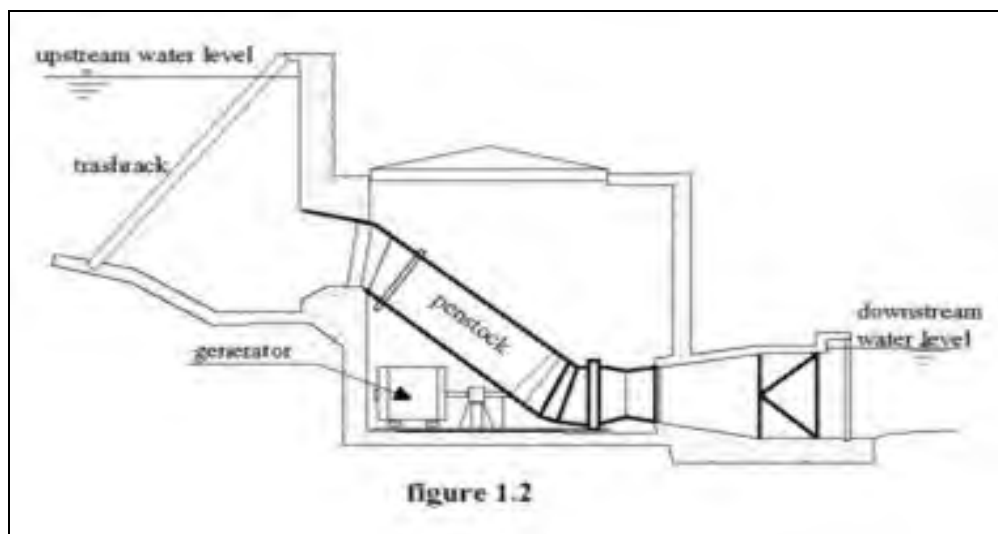
Medium and high head schemes use weirs to divert water to the intake, it is then conveyed to the turbines via a pressure pipe or penstock. Penstocks are expensive and consequently this design is usually uneconomic. An alternative (figure 1.1) is to convey the water by a low-slope canal, running alongside the river to the pressure intake or forebay and then in a short penstock to the turbines. If the topography and morphology of the terrain does not permit the easy layout of a canal

a low pressure pipe, can be an economical option. At the outlet of the turbines, the water is discharged to the river via a tailrace.



**Figure 1-1 High head scheme**

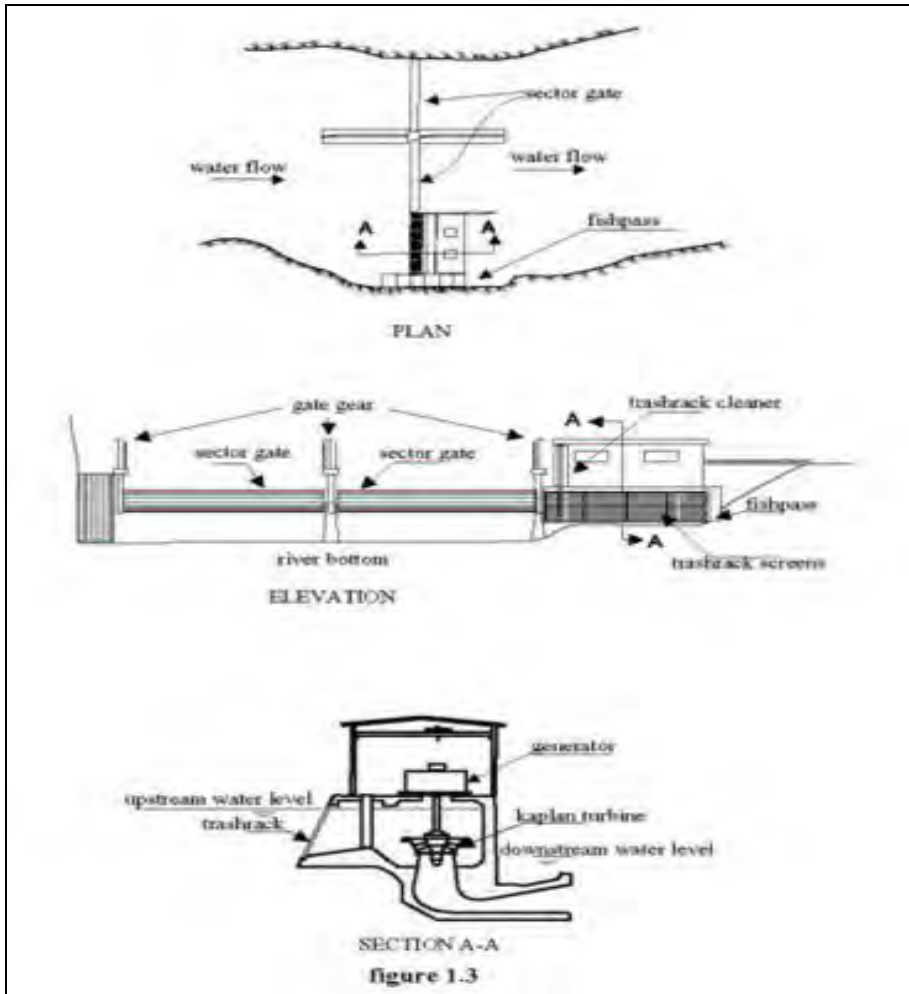
Occasionally a small reservoir, storing enough water to operate only on peak hours, when prices for electricity are higher, can be created by the weir, or a similarly sized pond can be built in the forebay.



**Figure 1-2 Low head scheme with penstock**

Low head schemes are typically built in river valleys. Two technological options can be selected. Either the water is diverted to a power intake with a short penstock (figure 1.2), as in the high head schemes, or the head is created by a small dam, provided with sector gates and an integrated intake (figure 1.3), powerhouse and fish ladder.

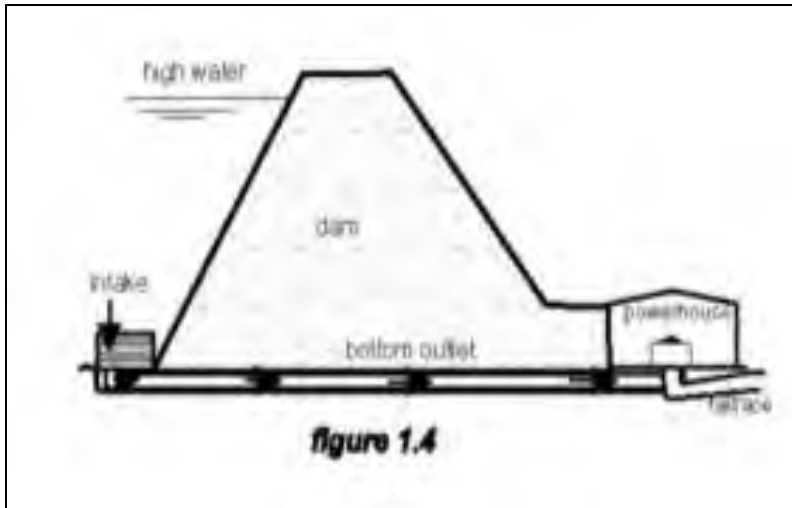




**Figure 1-3 Low head scheme integrated in the dam**

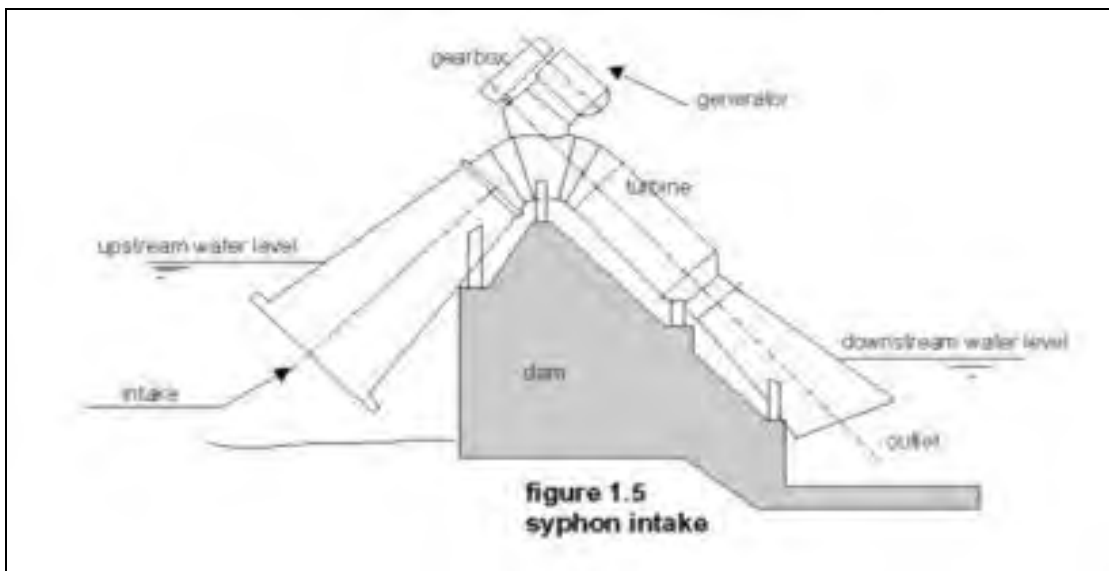
1.3.2 Schemes with the powerhouse at the base of a dam

A small hydropower scheme cannot afford a large reservoir to operate the plant when it is most convenient, the cost of a relatively large dam and its hydraulic appurtenances would be too high to make it economically viable. But if the reservoir has already been built for other purposes, such as flood control, irrigation, water abstraction for a big city, recreation area, etc, - it may be possible to generate electricity using the discharge compatible with its fundamental use or the ecological flow of the reservoir. The main issue is how to link headwater and tail water by a waterway and how to fit the turbine in this waterway. If the dam already has a bottom outlet, see figure 1.4, for a possible solution.



**Figure 1-4 Low head scheme using an existing dam**

Provided the dam is not too high, a siphon intake can be installed. Integral siphon intakes (figure 1.5) provide an elegant solution in schemes, generally, with heads up to 10 metres and for units up to about 1000 kW, although there are examples of siphon intakes with an installed power up to 11 MW (Sweden) and heads up to 30.5 meters (USA). The turbine can be located either on top of the dam or on the downstream side. The unit can be delivered pre-packaged from the works, and installed without major modifications to the dam.

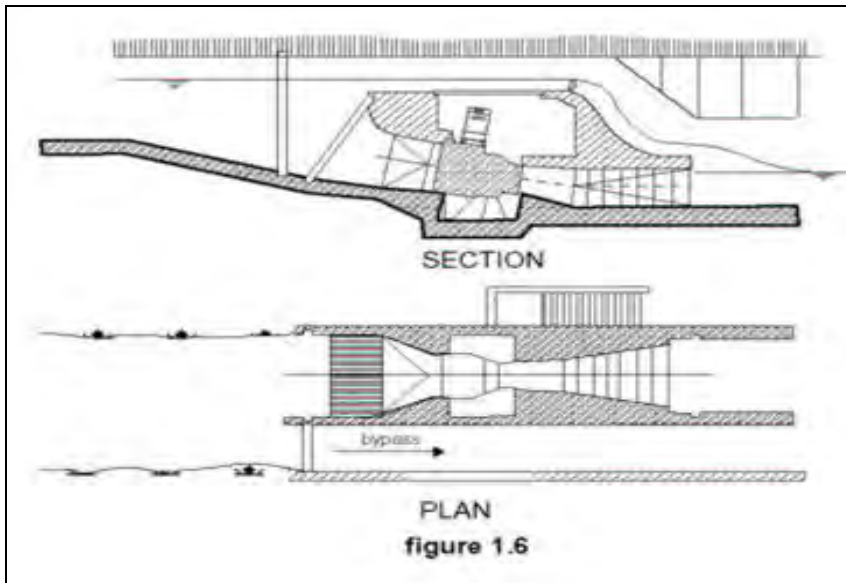


**Figure 1-5 Low head scheme – siphon intake**

### 1.3.3 Schemes integrated within an irrigation canal

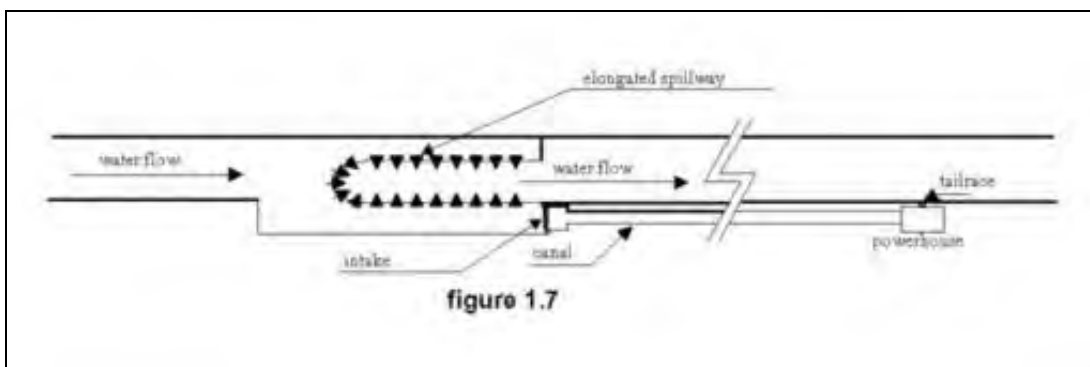
Two types of schemes can be designed to exploit irrigation canal:

- The canal is enlarged to accommodate the intake, the power station, the tailrace and the lateral bypass. Figure 1.6 shows a scheme of this kind, with a submerged powerhouse equipped with a right angle drive Kaplan turbine. To safeguard the water supply for irrigation, the scheme should include a lateral bypass, as in the figure, in case of shutdown of the turbine. This kind of scheme must be designed at the same time as the canal, as additional works whilst the canal is in full operation can be a very expensive option



**Figure 1-6 Integrated scheme using an irrigation canal**

- If the canal already exists, a scheme like the one shown in figure 1.7 is a suitable option. The canal should be slightly enlarged to include the intake and the spillway. To reduce the width of the intake to a minimum, an elongated spillway should be installed. From the intake, a penstock running along the canal brings the water under pressure to the turbine. The water passes through the turbine and is returned to the river via a short tailrace.



**Figure 1-7 Elongated spillway scheme using an irrigation canal**

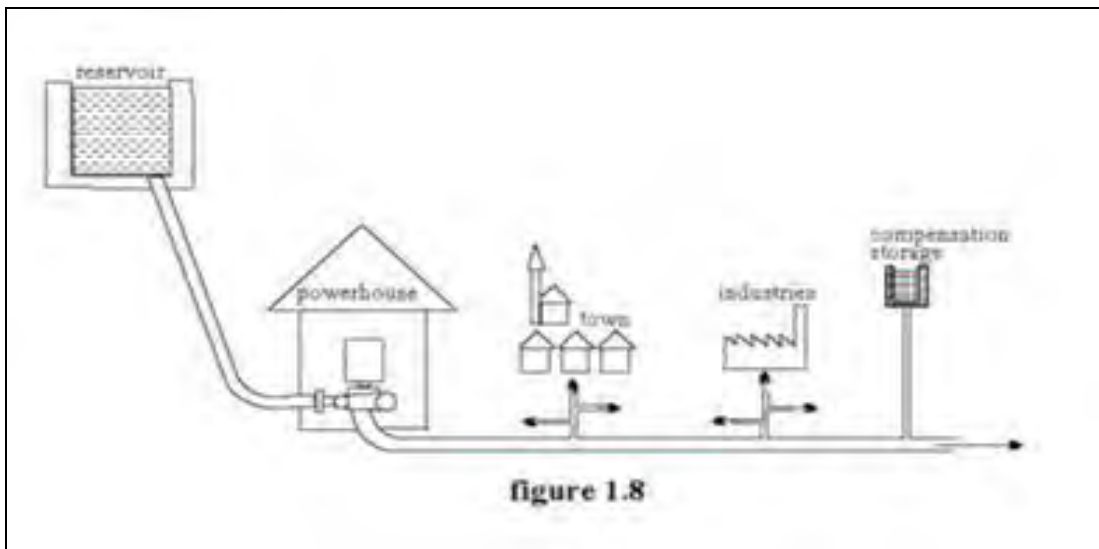
Generally, migratory fish are not present in canals, fish passes are unnecessary.

1.3.4 Schemes integrated in a water abstraction system

The drinking water is supplied to a city by conveying the water from a headwater reservoir via a pressure pipe. Usually in this type of installation, the dissipation of energy at the lower end of the pipe at the entrance to the Water Treatment Plant is achieved through the use of special valves. The fitting of a turbine at the end of the pipe, to convert this otherwise lost energy to electricity, is an attractive option, provided that the water hammer phenomenon is avoided. Water hammer overpressures are especially critical when the turbine is fitted on an old pressure pipe.

To ensure the water supply at all times, a system of bypass valves should be installed. In some water supply systems the turbine discharges to an open-air pond. The control system maintains the level of the pond. In case mechanical shutdown or turbine failure, the bypass valve system can also maintain the level of the pond. Occasionally if the main bypass valve is out-of-operation and overpressure occurs, an ancillary bypass valve is rapidly opened by a counterweight. All the opening and closing of these valves must be slow enough to keep pressure variations within acceptable limits.

The control system has to be more complex in those systems where the turbine outlet is subject to the counter-pressure of the network, as is shown in figure 1.8.



**Figure 1-8 Scheme integrated in a water supply system**

1.4 Planning a small hydropower scheme

The definitive project or scheme comes as the result of a complex and iterative process, where consideration is given to the environmental impact and different technological options. These are then costed and an economic evaluation carried out.

Although it is not easy to provide a detailed guide on how to evaluate a scheme, it is possible to describe the fundamental steps to be followed, before deciding if one should proceed to a detailed feasibility study or not. A list of the studies that should be undertaken:

- Topography and geomorphology of the site.
- Evaluation of the water resource and its generating potential
- Site selection and basic layout
- Hydraulic turbines and generators and their control
- Environmental impact assessment and mitigation measures
- Economic evaluation of the project and financing potential
- Institutional framework and administrative procedures to attain the necessary consents

The water flowing along natural and man-made canals, conducted by low and high-pressure pipes, spilling over weir crests and moving the turbines involves the application of fundamental engineering principles in fluid mechanics. In Chapter 2 those principles are reviewed together with shortcuts arising from the experience accumulated from centuries of hydraulic systems construction.

To decide if a scheme will be viable it is necessary to begin by evaluating the water resource existing at the site. The energy potential of the scheme is proportional to the product of the flow and the head. Except for very low heads, the gross head can usually be considered as constant, but the flow varies over the year. To select the most appropriate hydraulic equipment and estimate the sites potential with calculations of the annual energy output, a flow-duration curve is most useful. A single measurement of instantaneous flow in a stream has little value.

Measuring the gross head requires a topographical survey. The results obtained, by using a surveyor's level and staff is accurate enough, but the recent advances in electronic surveying equipment make the topographical surveying work much simpler and faster. To produce a flow-duration curve on a gauged site is easier than producing a curve at an ungauged site. This requires a deeper understanding of hydrology. In Chapter 3 various methods for measuring the quantity of water flowing in a stream are analysed and hydrological models to calculate the flow regime at ungauged sites are discussed.

Chapter 4 presents techniques such as orthophotography, RES, GIS, geomorphology, geotectonics, etc - used nowadays for site evaluation. Some failures are also analysed and conclusions about how they might have been avoided are explained.

In Chapter 5 the basic layouts are explained and the hydraulic structures, such as weirs, canals, spillways, intakes and penstocks, studied in detail.

Chapter 6 deals with the electromechanical equipment used to convert the potential energy of the mass of water to electricity. Turbines themselves are not studied in detail, but attention is focused on turbine configurations, specifically for low head schemes, and on the process of turbine selection, with emphasis on specific speed criteria. Since small hydro schemes are usually operated unattended, the control systems, based on personal computers, are also reviewed.

An Environmental Impact Assessment may be required to obtain the necessary consents to build the scheme and utilize the water available. Although several recent studies have shown that small hydropower produce no emissions to atmosphere, nor do they produce toxic wastes, does not contribute to climatic change, designers should implement all necessary measures to mitigate local ecological impacts. Chapter 7 analyses those impacts and mitigating measures.

Chapter 8 reviews techniques for an economical evaluation of a scheme. Various methodologies of economic analysis are described and illustrated with tables showing the cash flows generated by the schemes.

In Chapter 9, the administrative procedures a developer will have to go through are presented. Unfortunately the recent deregulation of much of the electricity industry in the EU has made it difficult to establish a common procedure to follow.

A few years ago ESHA produced (December 1994) on behalf of the E.C. DGXVII, a report "Small Hydropower. General Framework for Legislation and Authorisation Procedures in the European Union", and though it is not current it still has many valid aspects. The report can be found in [www.eshab.be](http://www.eshab.be), the ESHA web page.

Further important considerations for the developer to take into account are trading tariffs for green and base energy and administrative procedures, for grid connection. These depend on the energy policy and the institutional framework of each country. An overview has been provided in the Appendix A of Chapter 9.

---

<sup>i</sup> By Celso Penche (ESHA), Francis Armand (ADEME), Vincent Dennis (MhyLab) and Christer Söderberg (SERO)

## CHAPTER 2: FUNDAMENTALS OF HYDRAULIC ENGINEERING

### CONTENTS

2. FUNDAMENTALS OF HYDRAULIC ENGINEERING .....	13
2.1. Introduction.....	13
2.2. Water flow in pipes.....	13
2.2.1. Head losses due to friction.....	16
2.2.2. Local head losses .....	23
2.2.2. Transient flow .....	28
2.3. Water flow in open channels.....	31
2.3.1. Classification of open channel flows .....	31
2.3.2. Uniform flow in open channels.....	32
2.3.3. Efficient cross-section in open channels.....	33
2.3.4. Principles of energy in open channel flows .....	33
Bibliography .....	40

### LIST OF FIGURES

Figure 2-1 Velocity distribution for laminar and turbulent flow .....	14
Figure 2-2 Hydraulic gradient and energy gradient.....	16
Figure 2-3 $\mu$ as a function of Reynolds number .....	20
Figure 2-4 Loss coefficients for trash racks.....	24
Figure 2-5 $K_c$ and $K_{ex}$ values as a function of $d/D$ .....	25
Figure 2-6 Diffuser coefficients.....	26
Figure 2-7 Entrance loss coefficients.....	27
Figure 2-8 Loss coefficients for flow in bends .....	27
Figure 2-9 Typical loss coefficients for flow through valves .....	28
Figure 2-10 Typical velocity distributions for open channel flow .....	31
Figure 2-11 Illustration of various types of varied flow .....	32
Figure 2-12 Pressure distribution for channels with vertically curved bed .....	34
Figure 2-13 Specific energy as a function of flow depth.....	36
Figure 2-14 Moody's Chart: Friction factors for pipe flow.....	39
Figure 2-15 Illustration of pressure wave in pipes.....	39

### LIST OF TABLES

Table 2-1 Roughness height "e", for various commercial pipes.....	17
Table 2-2 Manning coefficient n for several commercial pipes .....	21
Table 2-3 Hazen-Williams coefficients .....	23
Table 2-4 Additional trash rack losses for non-perpendicular approach flows .....	24
Table 2-5 Geometrical characteristics of different channel profiles.....	37
Table 2-6 Empirical formulae used to estimate $y_c$ , in typical channel. ....	37

## 2. FUNDAMENTALS OF HYDRAULIC ENGINEERING<sup>i</sup>

### 2.1. Introduction

Hydraulic engineering is based on the principles of fluid mechanics, although many empirical relationships are applied to achieve practical engineering solutions. Until now there does not exist and probably never will, a general methodology for the mathematical analysis of the movement of fluids. Based on the experience accumulated, over many years of study and practice, there are particular solutions to specific problems. Experience that goes back 2500 years, when a massive irrigation system, that is still operative, was built in Sichuan, China, and to the many aqueducts built during the period of the Roman Empire

In hydropower, hydraulic engineering is applied to:

- .Optimise the performance of waterways to reduce energy losses
- .Design spillways and structure for floods prevention
- .Design adequate energy dissipation works downstream of spillways
- .Control erosion and manage silt transportation

Control phenomena such as:

- Instability in waterways due to dynamic effects
- Air entrance into closed conduits
- Surges in long waterways
- Surge pressures in closed conduits
- Cavitation of structures and equipment
- Prevent reservoir sedimentation, intake obstruction and sediment related damage to the hydraulic circuit and the equipment

In order to successfully develop small hydropower a thorough understanding of the principles of hydraulics is required.

In this chapter, the fundamentals of hydraulic engineering are explained together with an explanation of some of the phenomena mentioned above.

### 2.2. Water flow in pipes

A body of water will have a potential energy by virtue of its velocity and the vertical height through which it drops, (as a difference in water levels is what drives the flow of water), which is known as its “head”. This energy is its “Gravitational Potential Energy” which is product of mass, acceleration due to the effects of gravity and head  $m.g.h$  and is generally expressed in Joules (J)

The energy head in the water flowing in a closed conduit of circular cross section, under a certain pressure, is given by Bernoulli's equation:

$$H_1 = h_1 + \frac{P_1}{\gamma} + \frac{V_1^2}{2g}$$

(2.1)

Where:

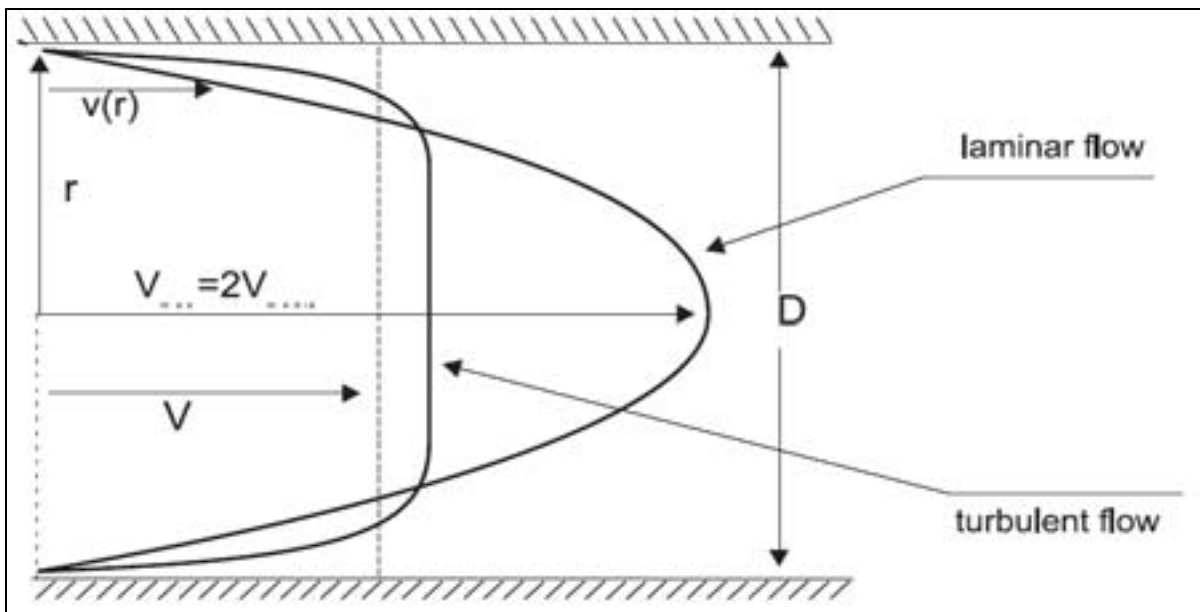


- $H_1$  is the total energy head
- $h_1$  is the elevation above some specified datum plane,
- $P_1$  the pressure
- $\gamma$  the specific weight of water
- $V_1$  the velocity of the water, and
- $g$  the gravitational acceleration.

The total energy head at point 1 is then the algebraic sum of the potential energy  $h_1$ , the pressure energy  $P_1/\gamma$ , and the kinetic energy  $V_1^2/2g$ , commonly known as the “Velocity head”.

For an open channel, the same equation applies, but with the term  $P_1/\gamma$  replaced by  $d_1$ , the water depth.

If water is allowed to flow very slowly in a long, straight, glass pipe of small bore into which a fine stream of coloured water is introduced at the entrance to the pipe, the coloured water would appear as a straight line all along the pipe. This effect is known as laminar flow. The water flows in lamina (layers), like a series of thin walled concentric pipes. The outer virtual pipe adheres to the wall of the real pipe, while each of the inner ones moves at a slightly higher speed, which reaches a maximum value near the centre of the pipe. The velocity distribution has the form of a parabola and the average velocity (figure 2.1) is 50% of the maximum centre line velocity.



**Figure 2-1 Velocity distribution for laminar and turbulent flow**

If the flow rate is gradually increased, a point is reached when the lamina flow suddenly breaks up and mixes with the surrounding water. The particles close to the wall mix up with the ones in the midstream, moving at a higher speed, and slow them. At that moment the flow becomes turbulent, and the velocity distribution curve is much flatter. Experiments carried out by Osborne Reynolds, near the end of the 19<sup>th</sup> century, found that the transition from laminar flow to turbulent flow depends, not only on the velocity, but also on the pipe diameter and on the viscosity of the fluid, and

is a ratio of the inertia force to the viscous force. This ratio, is known the Reynolds number and can be expressed, in the case of a circular pipe, by the equation:-

$$R_e = \frac{D \cdot V}{\nu} \tag{2.2}$$

where:

D (m) is the pipe diameter

V is the average water velocity (m/s), and

$\nu$  is the kinematics viscosity of the fluid (m<sup>2</sup>/s).

From experimentation it has been found that for flows in circular pipes the critical Reynolds number is about 2000. In fact this transition does not always happen at exactly  $R_e=2000$  but varies with the conditions. Therefore there is more than a transition point, what exists is a transition range.

**Example 2.1**

**A 60-mm diameter circular pipe carries water at 20°C. Calculate the largest flow-rate for which the flow would be laminar.**

The kinematics viscosity of water at 20°C is  $\nu = 1 \times 10^{-6} \text{ m}^2/\text{s}$ .

Assuming a conservative value for  $R_e = 2\ 000$

$$V = 2\ 000 / (10^6 \times 0.06) = 0.033 \text{ m/s}$$

$$Q = AV = \pi / 4 \times 0.06^2 \times 0.033 = 3.73 \times 10^{-4} \text{ m}^3/\text{s} = 0.373 \text{ l/s}$$

Water loses energy as it flows through a pipe, fundamentally due to:

1. friction against the pipe wall
2. viscous dissipation as a consequence of the internal friction of flow

The friction against the pipe wall depends on the wall material roughness and the velocity gradient nearest to the wall. Velocity gradient, as can be seen in figure 2.1, is higher in turbulent flow than in laminar flow. Therefore, as the Reynolds number increases, the friction loss will also increase. At the same time, at higher turbulences there is more intensive mixing of particles, and hence a higher viscous dissipation. Consequently the energy losses in flow in the pipe increase with the Reynolds number and with the wall pipe roughness. It can be verified that for water flowing between two sections, a certain amount of the head of energy  $h_f$  is lost:-

$$\frac{V_1^2}{2g} + \frac{P_1}{\gamma} + h_1 = \frac{V_2^2}{2g} + \frac{P_2}{\gamma} + h_2 + h_f \tag{2.3}$$

Due firstly, to the friction of the water against the pipe wall, and secondly, to the internal friction of the flow. In figure 2.2, HGL is the hydraulic gradient line and EGL the energy gradient line. If the pipe cross-section is constant,  $V_1 = V_2$  and both lines will be parallel. It is therefore necessary to determine the value of  $h_f$  ?

2.2.1. Head losses due to friction

Darcy and Weisbach, applying the principle of conservation of mass to a certain volume of fluid in a pipe, between two sections perpendicular to its axis - derived the following equation, valid for incompressible and steady flows, through pipes:

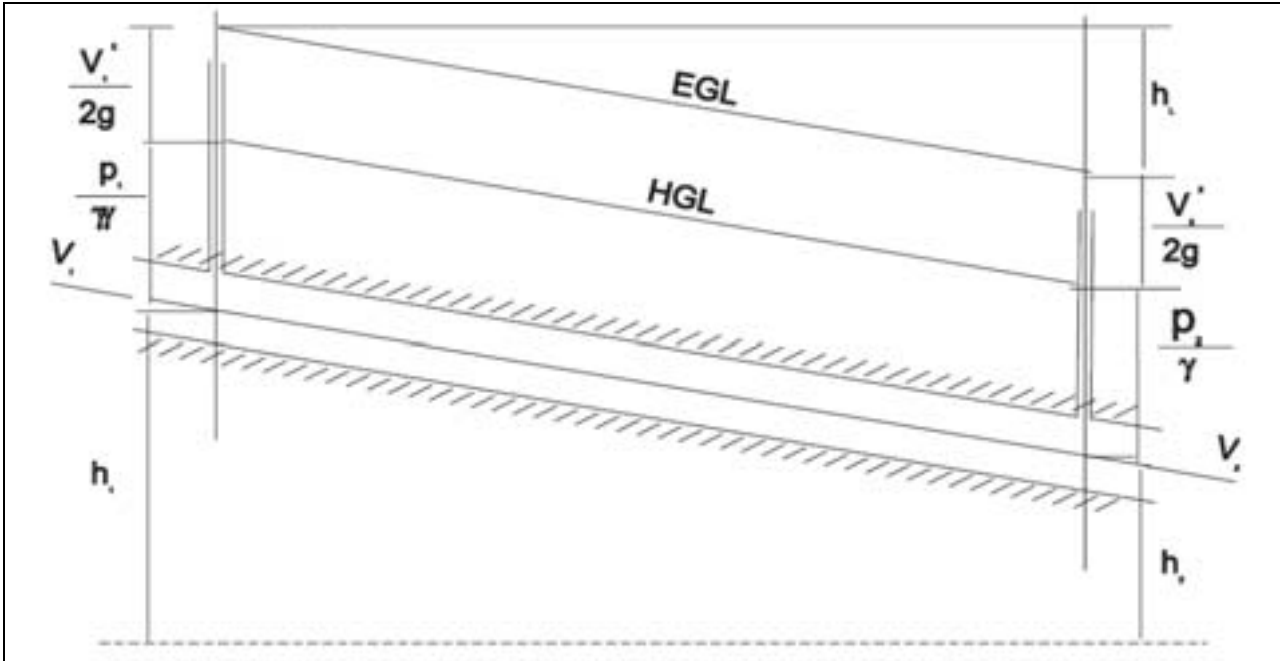


Figure 2-2 Hydraulic gradient and energy gradient

$$h_f = f \cdot \left(\frac{L}{D}\right) \cdot \frac{V^2}{2g} \quad (2.4)$$

where

- f = friction factor, a dimensionless number
- L = the length of the pipe in m
- D = the pipe diameter in m
- V = the average velocity in m/s, and
- g = the gravitational acceleration (9.81 m/s<sup>2</sup>).

In a laminar flow f can be calculated directly by the equation:

$$f = \frac{64 \cdot \nu}{V \cdot D} = \frac{64}{R_e} \quad (2.5)$$

According to equation (2.5) the friction factor f in a laminar flow is independent of the wall roughness and inversely proportional to the Reynolds number. The fact that, apparently, f decreases when  $R_e$  increases, does not mean that increasing the velocity decreases the friction losses.

Substituting f in equation (2.4) by its value in (2.5), gives:

$$h_f = \frac{64 \cdot \nu}{V \cdot D} \cdot \frac{L}{D} \cdot \frac{V^2}{2g} = \frac{32 \cdot \nu \cdot L \cdot V}{g \cdot D^2} \tag{2.6}$$

This shows that the specific head loss, in laminar flow, is proportional to V and inversely proportional to D<sup>2</sup>.

When the flow is practically turbulent (Re>2000), the friction factor become less dependent on the Reynolds number and more dependent on the relative roughness height e/D, where "e" represents the average roughness height of irregularities on the pipe wall and D the pipe diameter. Some values of the roughness height "e" are provided in table 2.1.

**Table 2-1 Roughness height "e", for various commercial pipes**

Pipe material	e (mm)
Polyethylene	0.003
Fiberglass with epoxy	0.003
Seamless commercial steel (new)	0.025
Seamless commercial steel (light rust)	0.250
Seamless commercial steel (galvanised)	0.150
Welded steel	0.600
Cast iron (enamel coated)	0.120
Asbestos cement	0.025
Wood stave	0.600
Concrete (steel forms, with smooth joints)	0.180

It is well known that, even in turbulent flows, immediately next to the wall pipe there exists, a very thin layer of flow referred to as the laminar sub layer. When Re increases, the sub layer's thickness diminishes. Whenever the roughness height "e" is resolutely lower than the sub layer thickness the pipe is considered hydraulically smooth.

In a hydraulically smooth pipe flow, the friction factor f is not affected by the surface roughness of the pipe, and for this case Von Karman, developed the following equation for the friction factor f:

$$\frac{1}{\sqrt{f}} = 2 \cdot \log_{10} \left( \frac{R_e \sqrt{f}}{2.51} \right) \tag{2.7}$$

At high Reynolds numbers, the sub layer thickness becomes very small and the friction factor f becomes independent of Re and depends only on the relative roughness height. In this case the pipe is a hydraulically rough pipe, and Von Karman found that the friction factor f:

$$\frac{1}{\sqrt{f}} = 2 \cdot \log_{10} \left( 3.7 \frac{D}{e} \right) \tag{2.8}$$

In between these two extreme cases, the pipe behaves neither completely smooth nor completely rough, for this situation, Colebrook and White devised the following equation:

$$\frac{1}{\sqrt{f}} = -2 \cdot \log_{10} \left( \frac{e/D}{3.7} + \frac{2.51}{Re \sqrt{f}} \right) \quad (2.9a)$$

Which can be expressed in terms of the average velocity U by:-

$$U = -2 \sqrt{2gD \frac{h_f}{L}} \log \left( \frac{e/D}{3.7} + \frac{2.51\nu}{D \sqrt{2gD \frac{h_f}{L}}} \right) \quad (2.9b)$$

Formulae 2.7 and 2.9 are difficult to solve by hand, prompting Moody to prepare his well-known chart "Friction factors for pipe flow" (figure 2.15).

Looking to the chart it shows four different flow zones:

1. A laminar flow zone (shaded area in the diagram) where f is a linear function of R (equation 2.5)
2. A badly defined critical zone (shaded area)
3. A transition zone, starting with the smooth pipes (equation 2.7) and finishing in the dashed line where, in between, f depends both of Re and e/D (equation 2.9a)
4. A developed turbulence zone where f depends exclusively of e/D (equation 2.8)

### Example 2.2

**Calculate, using the Moody chart, the friction loss in a 900-mm diameter welded steel pipe along a length of 500 m, conveying a flow of 2.3 m<sup>3</sup>/s.**

The average water velocity is  $4Q / (\pi D^2) = 1.886 \text{ m/s}$

From the table 2.1,

$e = 0.6 \text{ mm}$  and therefore  $e/D = 0.6/900 = 0.000617$

$Re = DV / \nu = (0.9 \times 1.886) / 1.31 = 1.3 \times 10^6$  ( $\nu = 1.31 \times 10^{-6}$ )

In the Moody chart for  $e/D = 0.00062$  and  $Re = 1.3 \times 10^6$  we find  $f = 0.019$

From equation (2.4):

$$h_f = 0.019 \cdot \frac{500}{0.9} \cdot \frac{1.886^2}{2 \cdot 9.81} = 1.91 \text{ m}$$

In engineering practice the Colebrook-White formula (2.9) and the Moody diagram can be used to solve the following typical problems with flows in closed pipes:

1. Given U (or Q), D and e, compute  $h_f$ ;
2. Given U (or Q),  $h_f$  and e, compute D;
3. Given D,  $h_f$  and e, compute U (or Q);
4. Given U (or Q), D,  $h_f$ , compute e.

Problems in 3 and 4 above can be solved directly by using formula (2.9b), whereas the remainder problems require an iterative solution. The Moody's diagram provides a direct solution for the 1st and 4th problems. Alternatively, if you want to know what the maximum water velocity flowing in a

pipe of diameter D and length L, without surpassing a friction head loss hf you only need to use an independent variable  $\mu$ :

$$\mu = \frac{1}{2} f R_e^2 \tag{2.10}$$

Substituting  $R_e$  by its value in (2.2) and f by its value in (2.4) becomes:-

$$\mu = \frac{g D^3 h_f}{L v^2} \tag{2.11}$$

where all the parameters are known. Once  $\mu$  is computed, f is derived from (2.10) and substituted in (2.9) to attain:

$$R_e = -2\sqrt{2\mu} \log_{10} \left( \frac{e/D}{3.7} + \frac{2.51}{\sqrt{2\mu}} \right) \tag{2.12}$$

An equation that makes it possible to plot the  $R_e$  with respect to U for different values of e/D, is shown in figure 2.3, a variation of the Moody Chart where  $R_e$  can be estimated directly.

**Example 2.3**

**Estimate the flow rate of water at 10°C that will cause a friction head loss of 2m per km in a welded steel pipe, 1.5 m in diameter.**

Substitute values in equation (2.12), with  $e/D=0.6/1500 = 4 \times 10^{-4}$ ,

After computing U .

$$\mu = \frac{9.81 \cdot 1.5^3 \cdot 2}{1000 \cdot (1.31 \cdot 10^{-6})^2} = 3.86 \cdot 10^{10}$$

$$R_e = -2\sqrt{2 \cdot 3.86 \cdot 10^{10}} \log_{10} \left( \frac{4 \cdot 10^{-4}}{3.7} + \frac{2.51}{\sqrt{2 \cdot 3.86 \cdot 10^{10}}} \right) = 2.19 \cdot 10^6$$

$$V = \frac{R_e \cdot \nu}{D} = \frac{2.19 \cdot 10^6 \cdot 1.31 \cdot 10^{-6}}{1.5} = 1.913 \text{ m/s}; Q=V \cdot A=3.38 \text{ m}^3/\text{s}$$

Also based on the Colebrook-White equation there exists some other monographs, to compute the friction head loss on a pipe, given a certain flow, a certain pipe diameter, with a certain roughness coefficient such as the one shown in the next page and published by courtesy of Hydraulic Research, Wallingford U.K.

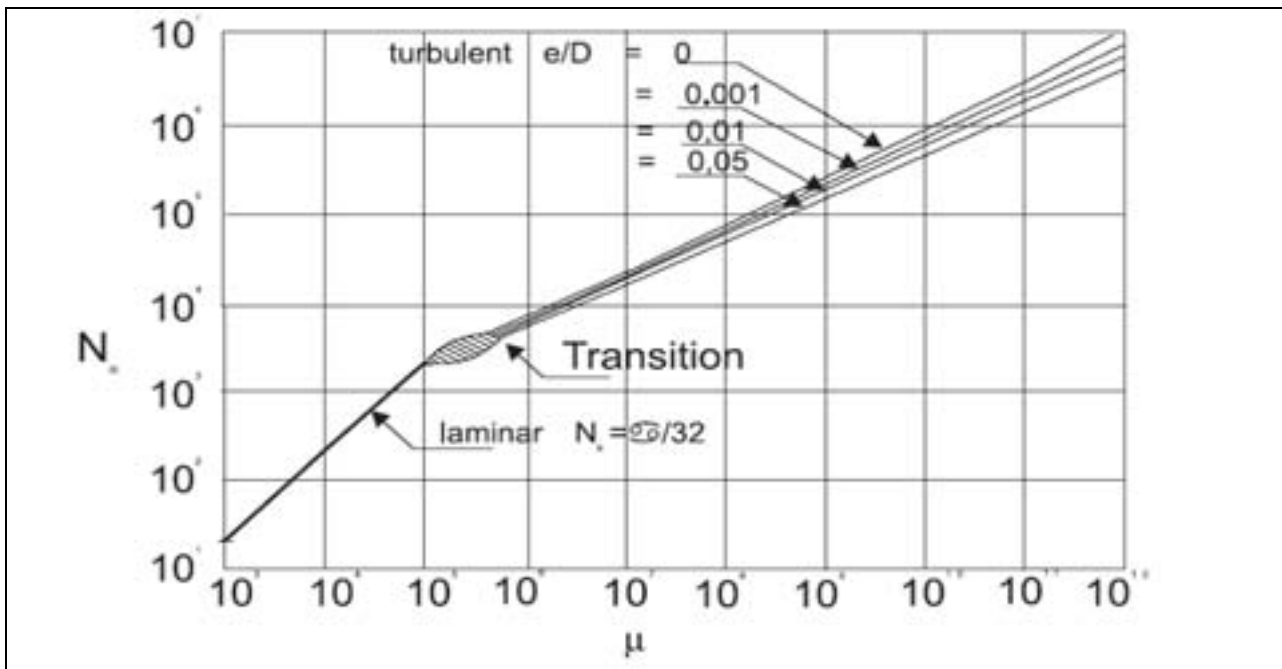


Figure 2-3  $\mu$  as a function of Reynolds number

Empirical formulae

Over the years many empirical formulae, based on accumulated experience, have been developed. They are, generally, not based on sound physics principles and even, occasionally, lack dimensional coherence, but are intuitively based on the belief that the friction on a closed full pipe is:

1. Independent of the water pressure
2. Linearly proportional to its length
3. Inversely proportional to a certain power of its diameter

4. Proportional to a certain exponent of the water velocity

In turbulent flows it is influenced by the wall roughness

One of these formulae, widely used to estimate the flow in open channels, but also applicable to closed pipes, is that developed by Manning (resp. Strickler):

$$Q = \frac{1}{n} \cdot \frac{A^{5/3} S^{1/2}}{P^{2/3}} \tag{2.13}$$

Where: n is the Manning roughness coefficient (s/m<sup>1/3</sup>, K<sub>Strickler</sub>=1/n)  
 P is the wetted perimeter (m)  
 A is cross-sectional area of the pipe (m<sup>2</sup>), and  
 S is the hydraulic gradient or head loss by linear meter (hf/L).  
 Applying the above formulae to a full closed circular cross section pipe:

$$S = \frac{10.29 \cdot n^2 \cdot Q^2}{D^{5.333}} \tag{2.14}$$

$$S = \frac{4^{10/3} n^2 Q^2}{\pi^2 D^{16/3}} \tag{2.14a}$$

In Table 2.2 the Manning coefficient n for several commercial pipes is shown:

**Table 2-2 Manning coefficient n for several commercial pipes**

Kind of pipe n	
Welded steel	0.012
Polyethylene (PE)	0.009
PVC	0.009
Asbestos cement	0.011
Ductile iron	0.015
Cast iron	0.014
Wood-stave (new)	0.012
Concrete (steel forms smooth finish)	0.014

In example 2.4 and more specifically in example 2.5 the results obtained by applying the Colebrook-White equation and the Manning formulae can be compared.

**Example 2.4**

**Using the parameters in example 2.2 compute the friction head loss applying the Manning formulae**

Accepting n=0.012 for welded steel pipe

$$\frac{h_f}{L} = \frac{10.29 \cdot 0.012^2 \cdot 1.2^2}{0.9^{5.333}} = 0.00374$$



Whereby for L=500 m, hf=1.87 m, slightly inferior to the value estimated with the Moody chart.

**Example 2.5**

**Compute, using the Colebrook equation and the Manning formulae, the friction head loss on a welded pipe 500 m long, of respectively 500 mm, 800 mm, 1 200 mm, and 1 500 mm diameter respectively, under a 4 m/s average flow velocity.**

D (mm)	500	800	1200	1500
Q (m <sup>3</sup> /s)	0.785	2.011	4.524	7.069
V (m/s)	4	4	4	4
L (m)	500	500	500	500

**Applying Colebrook-White**

e (mm)	0.6	0.6	0.6	0.6
hf(m)	17.23	9.53	5.73	4.35

**Applying Manning**

n	0.012	0.012	0.012	0.012
hf(m)	18.40	9.85	5.73	4.26

It can be observed that the solutions provided by the Manning formula do not differ much from those offered by the Colebrook equation, except in the smaller diameters, where the head loss provided by Manning is higher than that provided by Colebrook. In fact, both formulae agree for values of e/D=9.17E-3 and provide results within a 5 % range for values of e/D between 9E-4 and 5E-2 in the turbulent (rough) zone (Dubois, 1998). In this range of flows, the relation between the Darcy-Weisbach and Manning’s coefficients is:

$$S = \frac{f}{D} \frac{U^2}{2g}; f = \frac{2g \cdot 4^{4/3} n^2}{D^{1/3}} \tag{2.14b}$$

In North America for pipes larger than 5 cm diameter and flow velocities under 3 m/s the Hazen-Williams formulae is typically used:

$$h_f = \frac{6.87 \cdot L}{D^{1.165}} \left( \frac{V}{C} \right)^{1.85} \tag{2.15}$$

Where V is the flow velocity (m/s), D the diameter (m), L the pipe length (m) and C the Hazen-Williams coefficient such as shown in Table 2.3.

**Table 2-3 Hazen-Williams coefficients**

Pipe type	C
Asbestos cement	140
Cast iron	
New	130
10 years	107 - 113
20 years	89 - 100
30 years	75 - 90
Concrete	
Cast on site - steel forms	140
Cast on site - wood forms	120
Centrifugal cast	135
Steel	
Brush tar and asphalt	150
New uncoated	150
Riveted	110
Wood-stave (new)	120
Plastic pipes	135 - 140

### 2.2.2. Local head losses

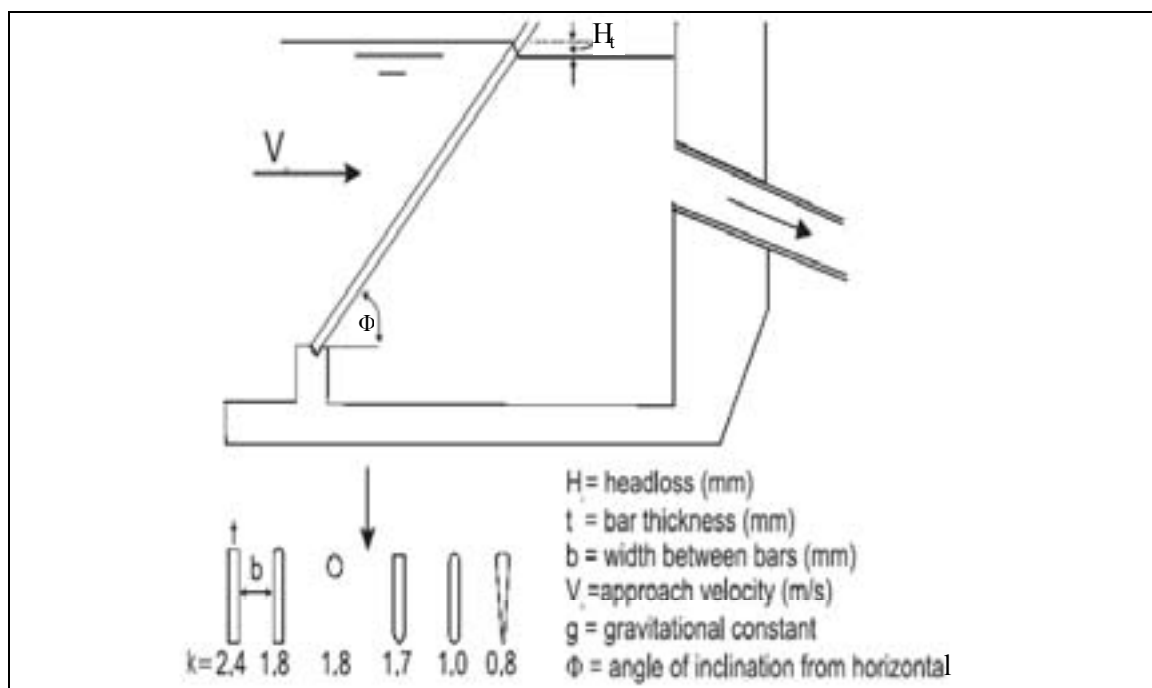
In addition to friction losses, water flowing through a pipe systems experience head losses due to geometric changes at entrances, bends, elbows, joints, racks, valves and at sudden contractions or enlargements of the pipe section. This loss also depends on the velocity and is expressed by an experimental coefficient K multiplied by the kinetic energy  $v^2/2g$ .

#### 2.2.1.1 **Trash rack (or screen) losses**

A screen is nearly always required at the entrance of both pressure pipes and intakes to avoid the entrance of floating debris. The flow of water through the rack also gives rise to a head loss. Though usually small, it can be calculated by a formula developed by Kirschmer:

$$h_t = Kt \left( \frac{t}{b} \right)^{4/3} \left( \frac{V_0^2}{2g} \right) \sin\Phi \tag{2.16}$$

where the parameters are identified in figure 2.4.



**Figure 2-4 Loss coefficients for trash racks**

For structural reasons, this formula is only valid if the length  $L$  of the bars is smaller than 5 times their diameter. If the grill is not perpendicular but makes an angle  $\beta$  with the water flow ( $\beta$  will have a maximum value of  $90^\circ$  for a grill located in the sidewall of a canal), there will be an additional head loss. The result of equation 2.16 should be multiplied by a correction factor  $\kappa$  provided in the table 2.4 (according to Mosonyi).

**Table 2-4 Additional trash rack losses for non-perpendicular approach flows**

$t/b$	1.0	0.9	0.8	0.7	0.6	0.5	0.4	0.3	0.2
$\beta$									
$0^\circ$	1.00	1.00	1.00	1.00	1.00	1.00	1.00	1.00	1.00
$10^\circ$	1.06	1.07	1.08	1.09	1.10	1.11	1.12	1.14	1.50
$20^\circ$	1.14	1.16	1.18	1.21	1.24	1.26	1.31	1.43	2.25
$30^\circ$	1.25	1.28	1.31	1.35	1.44	1.50	1.64	1.90	3.60
$40^\circ$	1.43	1.48	1.55	1.64	1.75	1.88	2.10	2.56	5.70
$50^\circ$	1.75	1.85	1.96	2.10	2.30	2.60	3.00	3.80	...
$60^\circ$	2.25	2.41	2.62	2.90	3.26	3.74	4.40	6.05	...

**2.2.1.2 Loss of head by sudden contraction or expansion**

When the pipe has a sudden contraction there is a loss of head due to the increase in velocity of the water flow and to the large-scale turbulence generated by the change of geometry. The flow path is so complex that, at least for the time being, it is impossible to provide a mathematical analysis of  $L$  the phenomenon. The head loss is estimated by multiplying the kinetic energy in the smaller pipe (section 2), by a coefficient  $K_c$  that varies with the ratio of contraction  $d/D$ :

$$h_c = K_c \cdot \left( \frac{V_2^2}{2g} \right) \tag{2.17}$$

For a ratio up to  $d/D = 0.76$ ,  $K_c$  approximately follows the formula:-

$$k_c = 0,42 \left( 1 - \frac{d^2}{D^2} \right) \tag{2.18}$$

The ratio,  $K_c$  is substituted by  $K_{ex}$ , the coefficient used for a sudden expansion.

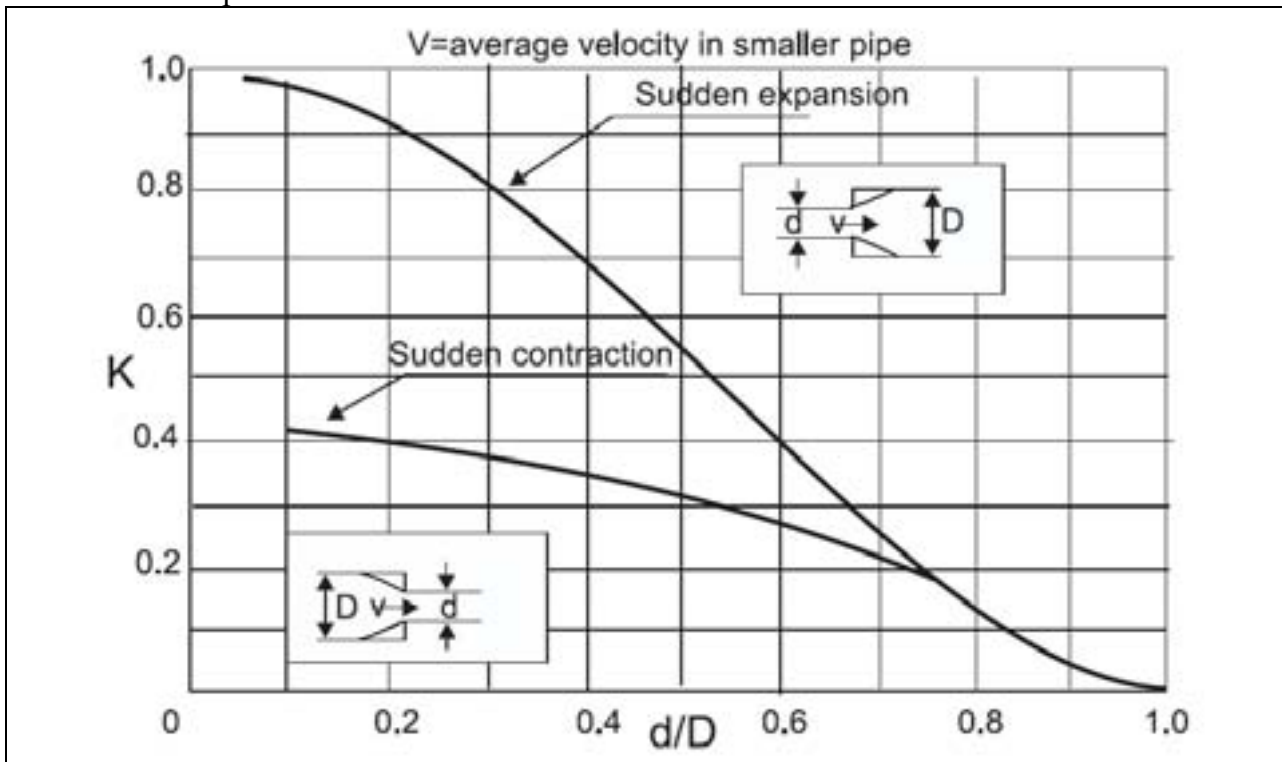
In sudden expansions, the loss of head can be derived from the momentum of flow and is given by:

$$h_{ex} = \frac{(V_1 - V_2)^2}{2g} = \left( 1 - \frac{V_2}{V_1} \right)^2 \frac{V_1^2}{2g} = \left( 1 - \frac{A_1}{A_2} \right)^2 \frac{V_1^2}{2g} = \left( 1 - \frac{d^2}{D^2} \right) \frac{V_1^2}{2g} \tag{2.19}$$

where  $V_1$  is the water velocity in the smaller pipe.

Figure 2.5 is a graphic representation of the  $K_c$  and  $K_{ex}$  values as a function of  $d/D$ .

The head loss can be reduced by using a gradual pipe transition, known as a confuser for contraction, or diffuser for expansion.



**Figure 2-5  $K_c$  and  $K_{ex}$  values as a function of  $d/D$**

In the confuser the head loss varies with the confuser angle as it is shown in the table below where  $K_c$  values are experimental:

Angle	$K_c$
$30^\circ$	0.02

45°	0.04
60°	0.07

In the diffuser the analysis of the phenomenon is more complex. Figure 2.6 shows the experimentally found values of  $K_{ex}$  for different diffuser angles. The head loss is given by:

$$h'_{ex} = K'_{ex} \frac{V_1^2 - V_2^2}{2g} \tag{2.20}$$

A submerged pipe discharging in a reservoir is an extreme case of a sudden expansion, where  $V_2$ , given the size of the reservoir, compared with the pipe, can be considered as zero, and the loss  $V_1^2/2g$ .

On the other hand, the entrance from a reservoir to a pipe is an extreme case of a sudden contraction. Figure 2.7 shows the value of the  $K_e$  coefficient that multiplies the kinetic energy  $V_2/2g$  in the pipe.

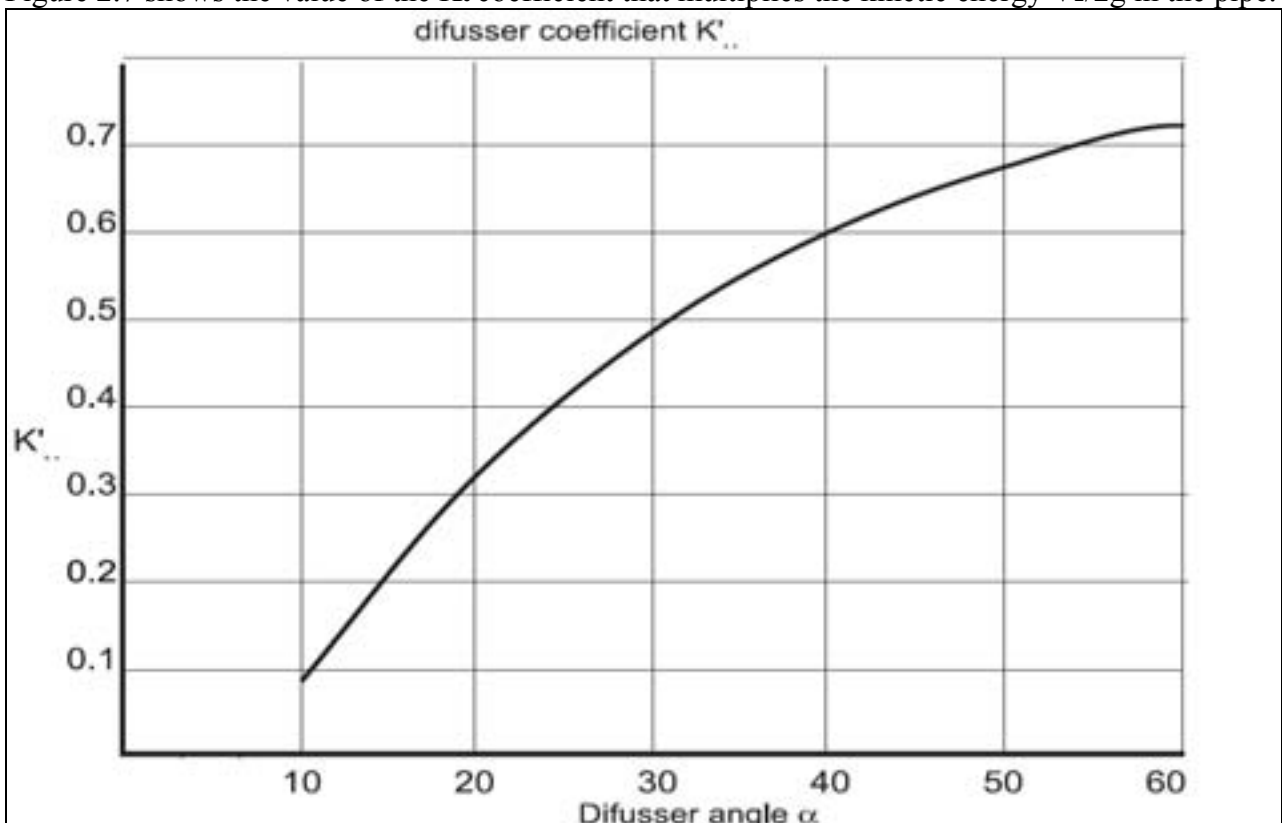
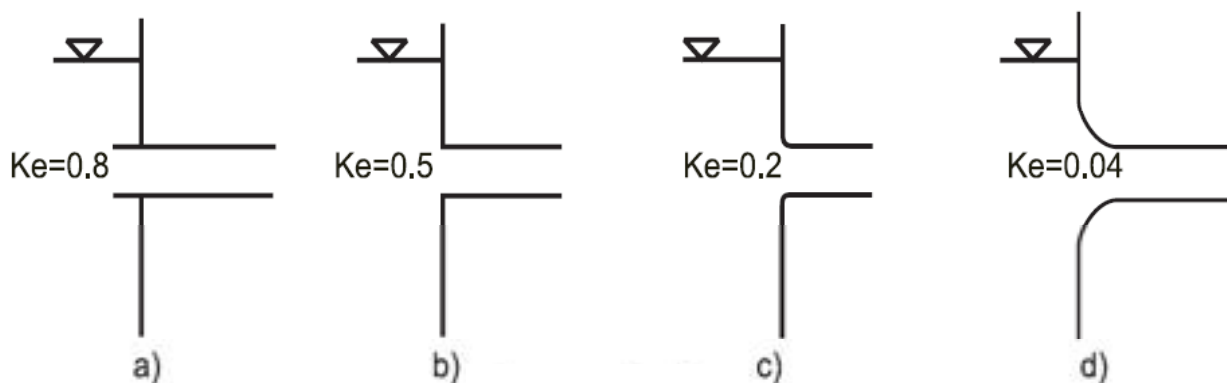


Figure 2-6 Diffuser coefficients

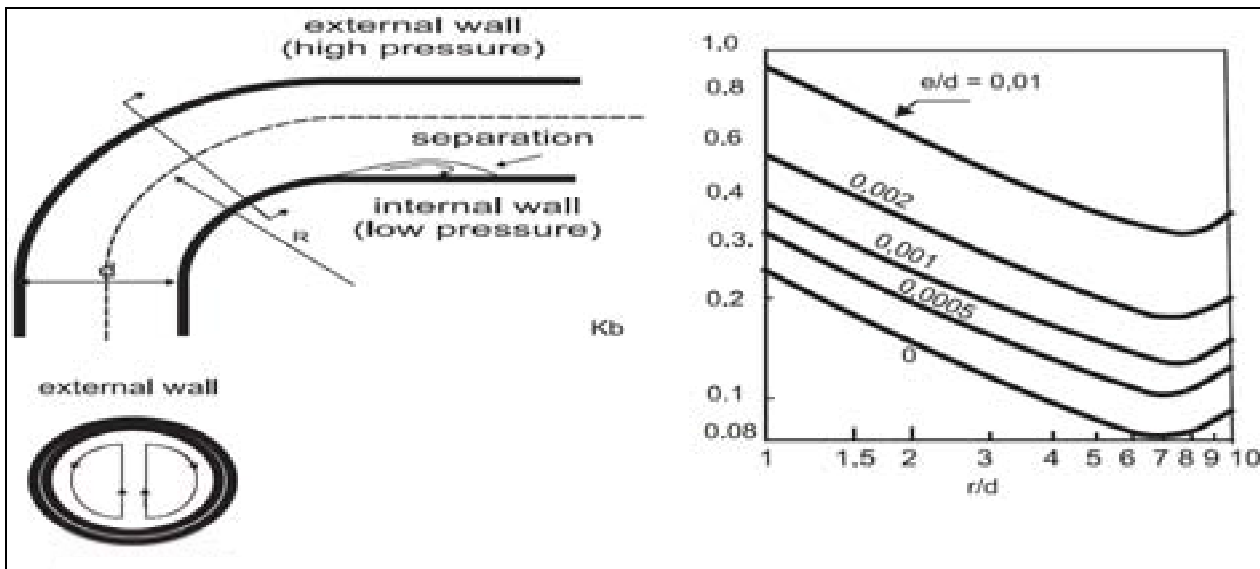


**Figure 2-7 Entrance loss coefficients**

**2.2.1.3 Loss of head in bends**

In a bend, pipe flow experiences an increase of pressure along the outer wall and a decrease of pressure along the inner wall. This pressure unbalance causes a secondary current such as shown in the figure 2.10. Both movements together - the longitudinal flow and the secondary current - produces a spiral flow that, at a length of around 100 diameters, is dissipated by viscous friction. The head loss produced in these circumstances depends on the radius of the bend and on the diameter of the pipe. Furthermore, in view of the secondary circulation, there is a secondary friction loss, dependent of the relative roughness  $e/D$ .

Figure 2.8, taken from reference 3 gives the value of  $K_b$  for different values of the ratio  $R/D$  and various relative roughness  $e/D$ . There is also a general agreement that, in seamless steel pipes, the loss in bends with angles under  $90^\circ$ , is almost proportional to the bend angle. The problem is extremely complex when successive bends are placed one after another, close enough to prevent the flow from becoming stabilized at the end of the bend. Fortunately, this is hardly ever the case in a small hydro scheme.



**Figure 2-8 Loss coefficients for flow in bends**

**2.2.1.4 Loss of head through valves**

Valves or gates are used in small hydro schemes to isolate a component from the rest, so they are either entirely closed or entirely open. Flow regulation is assigned to the distributor vanes or to the needle valves of the turbine. The loss of head produced by water flowing through an open valve depends of the type and manufacture of the valve. Figure 2.9 shows the value of  $K_v$  for different kind of valves.

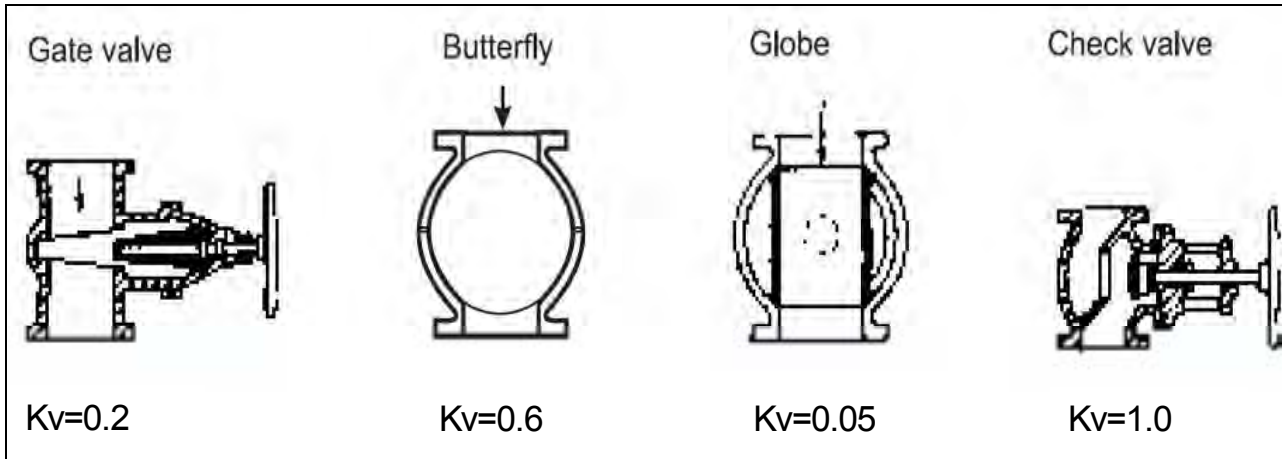


Figure 2-9 Typical loss coefficients for flow through valves

2.2.2 Transient flow

In steady flows where the discharge is assumed to remain constant with time, the operating pressure at any point along a penstock is equivalent to the head of water above that point. If a sudden change of flow occurs, for instance when the plant operator, or the governor system, open or close the gates too rapidly, the sudden change in the water velocity can cause dangerous high and low pressures.

This pressure wave is known as water hammer, or surge, and its effects can be dramatic. The penstock can burst from overpressure or collapse if the pressures are reduced below atmospheric. Although being transitional the surge pressure induced by the “water hammer phenomenon” can be of a magnitude several times greater than the static pressure due to the head. According to Newton’s second law of motion, the force developed in the penstock, by the sudden change in velocity, will be:

$$F = m \frac{dV}{dt} \tag{2.21}$$

If the velocity of the water column could be reduced to zero the resulting force would become infinite. Fortunately this is not possible in practice; a mechanical valve requires some time for total closure and the pipe walls are not perfectly rigid and the water column under large pressures is not incompressible.

The following description, reproduced with the permission of the author, Allen R. Inversin from Appendix F of his "Micro-Hydropower Sourcebook", is one of the best physical explanations of this phenomenon. Figure 2.16, enclosed at the end of this chapter, illustrates how a velocity change, caused by an instantaneous closure of a gate, or valve, at the end of a pipe creates a pressure wave that travels the length of the pipe.

Initially, water flows at a velocity (Vo) as shown in (a). When the gate is closed, the water flowing within the pipe has a tendency to continue flowing due to its momentum. Because this momentum is physically stopped by the gate closing, it “piles up” behind it, the kinetic energy of the element of water nearest the gate is converted to pressure energy, which slightly compresses the water and expands the circumference of the pipe at this point (b). This action is repeated by the following elements of water (c), and the wave front of increased pressure travels the length of the pipe until the velocity of the water Vo is destroyed, the water is compressed, and the pipe is expanded over its entire length (d). At this point, the water’s kinetic energy has all been converted to strain energy (under increased compression) and strain energy of the pipe (under increased tension).

Because the water in the reservoir remains under normal static pressure but the water in the pipe is now under a higher pressure, the flow reverses and is forced back into the reservoir again with velocity  $V_0$  (e). As the water under compression starts flowing back, the pressure in the pipe is reduced to normal static pressure. A pressure “unloading” wave then travels down the pipe toward the gate (f) until all the strain energy is converted back into kinetic energy (g). However, unlike case (a), the water is now flowing in the opposite direction and because of its momentum the water again tries to maintain this velocity. In so doing, it stretches the element of water nearest the gate, reducing the pressure there and contracting the pipe (h). This happens with successive elements of water and a negative pressure wave propagates back to the reservoir (i) until the entire pipe is under

compression and water under reduced pressure (j). This negative pressure wave would have the same absolute magnitude as the initial positive pressure wave if it were assumed that friction losses do not exist. The velocity then returns to zero but the lower pressure in the pipe compared to that in the reservoir forces water to flow back into the pipe (k). The pressure surge travels back toward the gate (e) until the entire cycle is complete and a second cycle commences (b). The velocity with which the pressure front moves is a function of the speed of sound in water modified by the elastic characteristics of the pipe material. In reality, the penstock pipe is usually inclined but the effect remains the same, with the surge pressure at each point along the pipe adding to or subtracting from the static pressure at that point. Also, the damping effect of friction within the pipe causes the kinetic energy of the flow to dissipate gradually and the amplitude of the pressure oscillations to decrease with time. Although some valves close almost instantaneously, closure usually takes at least several seconds. Still, if the valve is closed before the initial pressure surge returns to the gate end of the pipeline (g), the pressure peak will remain unchanged - all the kinetic energy contained in the water near the gate will eventually be converted to strain energy and result in the same peak pressure as if the gate were closed instantaneously. However, if the gate has been closed only partially, by the time the initial pressure surge returns to the gate (g), not all the kinetic energy will have been converted to strain energy and the pressure peak will be lower. If the gate then continues closing, the positive pressure surge, which it would then create, will be reduced somewhat by the negative pressure (h) surge which originated when the gate originally began closing. Consequently, if the gate opens or closes in more time than that required for the pressure surge to travel to the reservoir and back to the gate, peak surge pressures are reduced. This time is called the critical time,  $T_c$ , and is equal to:

$$T_c = 2L / c \tag{2.22}$$

where  $c$  is the wave velocity. The wave velocity, or speed of sound, in water is approximately 1420 m/s. However, the wave velocity in a pipe - the speed with which the pressure surge travels along the pipe - is a function of both the elastic characteristics of water and the pipe material. An expression for the wave velocity is:

$$c = \sqrt{\frac{k / \rho}{1 + \frac{k \cdot D}{E \cdot t}}} \tag{2.23}$$

- where  $K$  = bulk modulus of water,  $2.2 \times 10^9$  N/m<sup>2</sup>
- $\rho$  = density of water, 1 000 kg/m<sup>3</sup>
- $D$  = internal pipe diameter (m)
- $E$  = modulus of elasticity of pipe material (N/m<sup>2</sup>)
- $t$  = wall thickness (mm)



If the valve is already closed, when the pressure wave is on its way back ( $t < T_c$ ) all the kinetic energy of the water will be converted on an overpressure, and its value in meters of water column is:-

$$\frac{\Delta P}{\rho g} = \frac{c}{g} \Delta V \quad (2.24)$$

where  $\Delta V$  is the change of water velocity. In practical cases,  $\Delta V$  can be assumed equal to the initial flow velocity  $V_0$ . However, if  $t$  is greater than  $T_c$ , then the pressure wave reaches the valve before the valve is completely closed, and the overpressure will not develop fully, because the reflected negative wave arriving at the valve will compensate for the pressure rise. In this case the maximum overpressure may be calculated by the simplified Allievi formula, also known as the Michaud formula:-

$$\frac{\Delta P}{\rho g} = \frac{2L}{gt} \Delta V \quad (2.25)$$

where  $L$  = total pipe length (m)

$\Delta P/\rho g$  = pressure difference between the initial static pressure  $P_0/\rho g$  and the maximum pressure attained in the conduit (m column of water)  $t$  = closure time (s).

The total dynamic pressure experienced by the penstock will thus be:

$$P = P_0 + \Delta P \quad (2.26)$$

In chapter 5, several examples related to penstock design will clarify the above physics concepts. For a more rigorous approach it would be necessary to take into consideration not only the elasticity of the fluid and pipe material above, but also the hydraulic losses. The mathematical approach is rather cumbersome and requires the use of computers. For interested readers Chaudry, Fox and Parmakian, among others, give calculation methods, together with some worked examples.

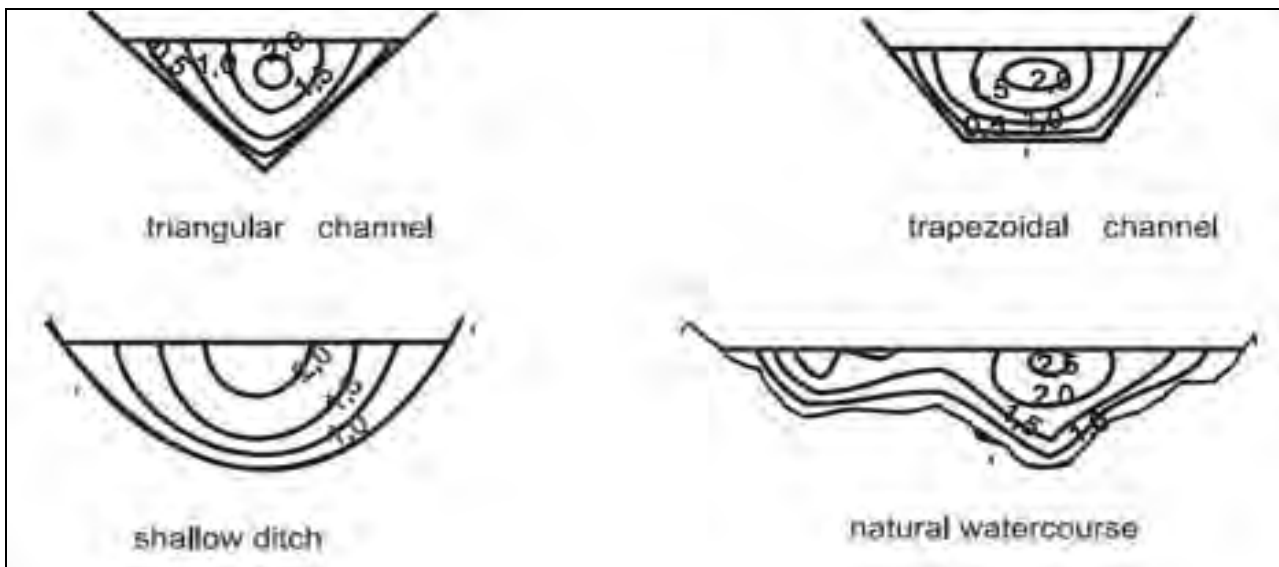
**2.3. Water flow in open channels**

In closed pipes the water fills the entire pipe, in an open canal there is always a free surface. Normally, the free water surface is subject to the atmospheric pressure, commonly referred to as the zero pressure reference, and usually considered as constant along the full length of the canal. In a way this fact, by dropping the pressure term, facilitates the analysis, but at the same time introduces a new dilemma. The depth of water changes with the flow conditions, and in unsteady flows its estimation is a part of the problem. Any kind of canal, even a straight one, has a three-dimensional distribution of velocities. A well-established principle in fluid mechanics is that any particle in contact with a solid stationary border has a zero velocity. Figure 2.10 illustrates the iso-velocity lines in channels of different profile. The mathematical approach is based on the theory of the boundary layer; the engineering approach is to deal with the average velocity  $V$ .

2.3.1. Classification of open channel flows

A channel flow is considered steady when the depth at any section of the stretch does not change with time, and unsteady if it changes with time. An open channel flow is said to be uniform if the discharge and the water depth at every section of a channel length does not change with time. Accordingly, it is said to be varied whenever the discharge and/or the water depth changes along its length. Non uniform flow is a rare occurrence, and with uniform flow, steady uniform flow is understood to occur. Steady variable flow is often stated as gradual or rapid.

Figure 2.11 represents different kinds of flows: steady uniform flow, steady gradually variable flow, and steady rapidly variable flow. Unsteady flow occurs if either the flow depth, or the discharge, over the length of the canal, changes as, for instance, in the case of upstream propagation of a small perturbation wave due to closure or opening of a valve, or in the case of the discharge increase in a collector channel.



**Figure 2-10 Typical velocity distributions for open channel flow**

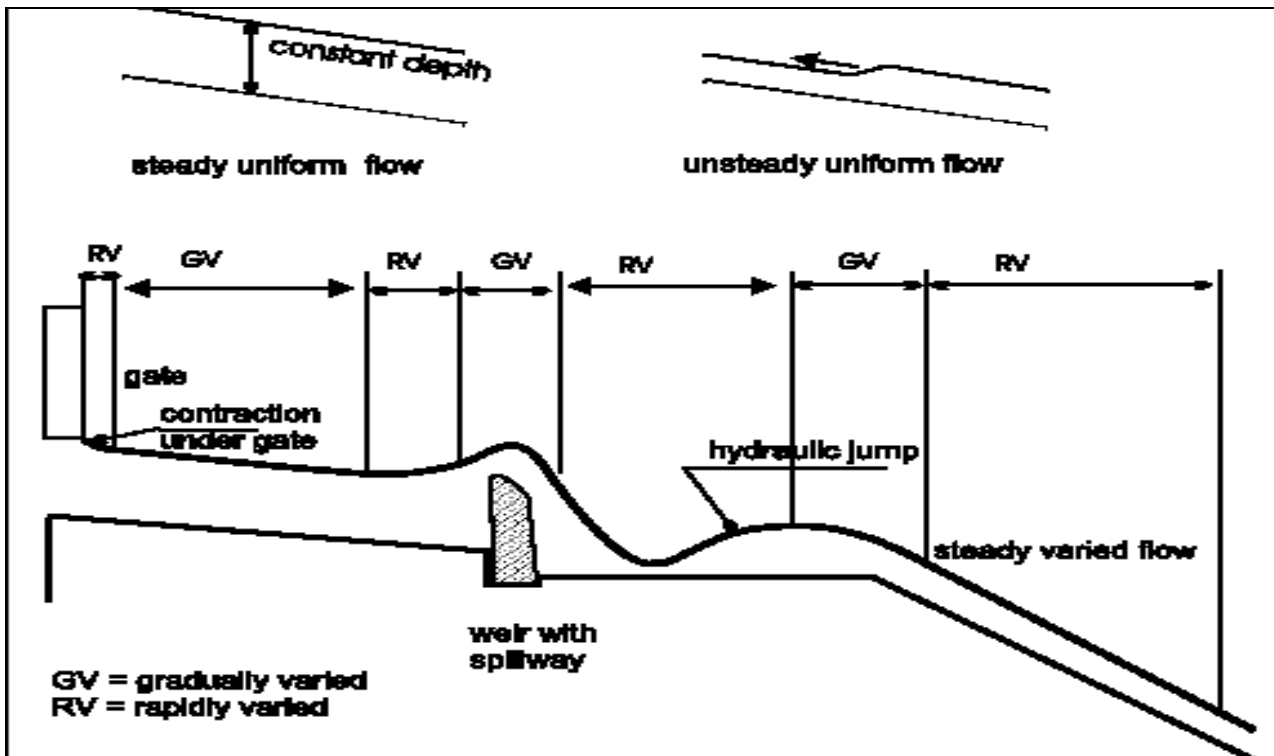


Figure 2-11 Illustration of various types of varied flow

As with the analysis of fully closed pipe flows, channel flows also follow Bernoulli’s equation and consequently formula (2.1) is valid. The amount of energy loss when water flows from section 1 to section 2 is indicated by  $h_L$ .

2.3.2. Uniform flow in open channels

By definition a flow is considered uniform when:

1. The water depth, water area, and the velocity in every cross section of the channel are constant.
2. The energy gradient line, the free surface line and the bottom channel line are parallel to each other.

Based on these concepts Chezy found that

$$V = C\sqrt{R_h S_e} \tag{2.27}$$

where:

- C Chezy’s resistance factor
- $R_h$  Hydraulic radius of the channel cross-section
- $S_e$  Channel bottom line slope

Many attempts had been made to determine the value of C. Manning, using the results of his own experiments and those of others, derived the following empirical relation:

$$C = \frac{1}{n} R_h^{1.485} \tag{2.28}$$

where n is the well-known Manning’s roughness coefficient (see Chapter 5, Table 5.2)

Substituting C from (2.27) into (2.28) we have the Manning formula for uniform flows:

$$V = \frac{1}{n} R_h^{2/3} S^{1/2} \quad (2.29)$$

or alternatively

$$Q = \frac{1}{n} A R_h^{2/3} S^{1/2} \quad (2.30)$$

The parameter  $AR_h^{2/3}$  has been defined as the section factor and is given, for various channel sections, in table 2.5. The formula is entirely empirical and the n coefficient is not dimensionless, so the formulae given here are only valid in S.I. units. Furthermore the formulae are only applicable to channels with a flat bottom. The analysis of natural watercourses is more complex and the above formulae can only be applied for first approximations.

### 2.3.3. Efficient cross-section in open channels

From (2.32) it may be deduced that for a channel with a certain cross-section area A and a given slope S, the discharge increases by increasing the hydraulic radius. That means the hydraulic radius is an efficiency index. As the hydraulic radius is the quotient of the area A and the wetted perimeter P, the most efficient section will be the one with the minimum wetted perimeter. Among all cross-sectional areas, the semicircle is the one, which has the minimum wetted perimeter for a given area. Unfortunately such a channel, with a semicircular cross section is expensive to build and difficult to maintain, and so is only used in small section channels built with prefabricated elements. Putting aside the semicircular section, the most efficient trapezoidal section is a half hexagon. The most commonly used channel section in small hydro schemes is the rectangular section, easy to build, waterproof and maintain. In chapter 5 the selection of the channel section is considered from the construction viewpoint, balancing efficiency, land excavation volumes, construction methods, etc.

### 2.3.4. Principles of energy in open channel flows

Uniform flows in open channels are mostly steady, and unsteady uniform flows are rather rare. If the flow lines are parallel and we take the free surface of the water as the reference plane, the summation of the elevation energy "h" and the pressure energy  $P/\gamma$  is constant and equal to the water depth. In practice, most of the uniform flows and a large part of the steady varied flows can be considered parallel to the bottom.

On a channel with a constant slope less than  $6^\circ$  (figure 2.12a), the pressure head at any submerged point is equal to the vertical distance measured from the free surface to that point (depth of water). The stress distribution is typically triangular. Nevertheless if the water is flowing over a convex path, such as a spillway, the centrifugal flow acts in an opposite direction to the gravity, and the stress distribution is distorted and looks like figure 2.12b. The pressure energy is given by the difference between the depth and the centrifugal acceleration of the water  $mv^2/r$ , being r the radius of curvature of the convex path. If the path is concave, the acceleration force is added to the depth and the stress distribution looks like in figure 2.12c. Consequently the resulting pressure head, for water flows along a straight line, a convex path and a concave path is respectively:

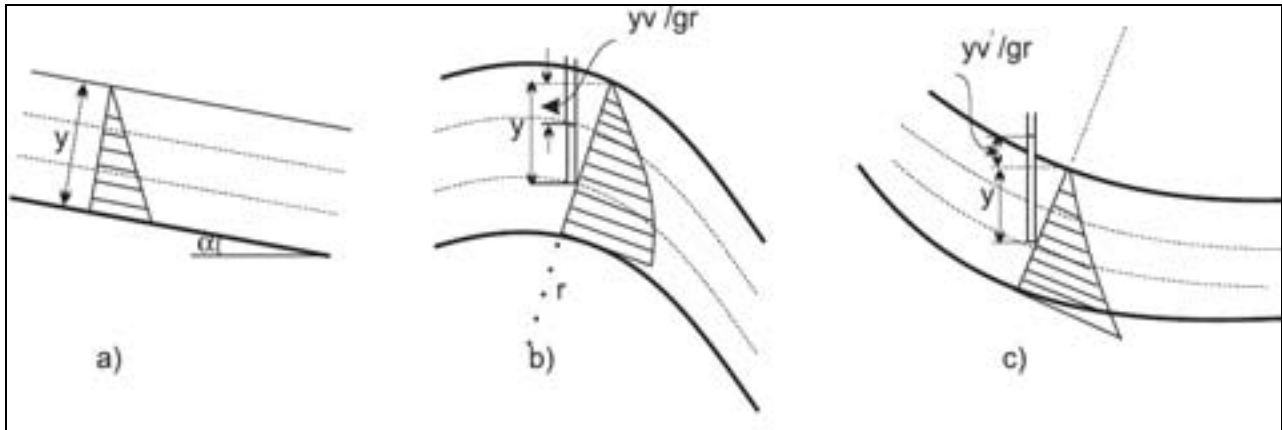


Figure 2-12 Pressure distribution for channels with vertically curved bed

$$\frac{P}{\gamma} = y \text{ (a)}; \frac{P}{\gamma} = y - y \cdot \frac{V^2}{rg} \text{ (b)}; \frac{P}{\gamma} = y + y \cdot \frac{V^2}{rg} \text{ (c)} \tag{2.31}$$

where:

$\gamma$  = the specific weight of water  
 $y$  = the depth measured from the free water surface to the point,  
 $y = h \cos \alpha$ ,  $h$  being the flow depth normal to the channel bottom

$V$  = the water velocity at that point,

$r$  = the radius of curvature of the curved flow path.

The specific energy in a channel section or energy head measured with respect to the bottom of the channel at the section is:

$$E = y + \alpha \frac{V^2}{2g} \tag{2.32}$$

where  $\alpha$  is a coefficient that takes into account the actual velocity distribution in the particular channel section, whose average velocity is  $V$ . The coefficient can vary from a minimum of 1.05 for a very uniform distribution, to 1.20 for a highly uneven distribution. Nevertheless in a preliminary approach a value of  $\alpha = 1$  can be used, a reasonable value when the slope is under 0.018 ( $\alpha < 1.03^\circ$ ). Equation 2.32 then becomes:-

$$E = y + \frac{V^2}{2g} \tag{2.33}$$

A channel section with a water area  $A$  and a discharge  $Q$ , will have a specific energy:

$$E = y + \frac{Q^2}{2gA^2} \tag{2.34}$$

Equation (2.34) shows that given a discharge  $Q$ , the specific energy at a given section, is a function of the depth of the flow only. When the depth of flow  $y$  is plotted, for a certain discharge  $Q$ , against the specific energy  $E$ , a specific energy curve, with two limiting boundaries, like the one represented

in figure 2.13 is obtained. The lower limit AC is asymptotic to the horizontal axis, and the upper AB to the line  $E=y$ . The vertex point A on the specific energy curve represents the depth  $y$  at which the discharge  $Q$  can be delivered through the section at a minimum energy. For every point over the axis  $E$ , greater than A, there are two possible water depths. At the smaller depth the discharge is delivered at a higher velocity and hence at a higher specific energy - a flow known as supercritical flow. At the larger depth the discharge is delivered at a smaller velocity, but also with a higher specific energy - a flow known as subcritical flow. In the critical state the specific energy is a minimum, and its value can therefore be computed by equating the first derivative of the specific energy (equation 2.34) with respect to "y" to zero.

$$\frac{dE}{dy} = -\frac{Q^2}{gA^3} \frac{dA}{dy} + 1 = 0 \tag{2.35}$$

The differential water area near the free surface,  $\delta A / \delta y = T$ , where  $T$  is the top width of the channel section (see figure 2.13). By definition:-

$$Y = A/t \tag{2.36}$$

The parameter  $Y$  is known as the "hydraulic depth" of the section, and it plays a key role in studying the flow of water in a channel.

Substituting in equation (2.35)  $\delta A / \delta y$  by  $T$  and  $A/T$  by  $Y$  one obtains:

$$\frac{V}{\sqrt{gY}} = 1 \tag{2.37 a}$$

Where:

$$F_r = \frac{V}{\sqrt{gY}} \tag{2.37 b}$$

The quantity  $F_r$  is dimensionless and known as the Froude number. When  $F_r = 1$ , as in equation (2.37 a), the flow is in the critical state. The flow is in the supercritical state when  $F_r > 1$  and in the subcritical state when  $F_r < 1$ . In Figure 2.13, the AB line represents the supercritical flows and the AC the subcritical ones. As shown in figure 2.13, a family of similar curves can be drawn for the same section and different discharges  $Q$ . For higher discharges the curve moves to the right and for lower discharges to the left.

In the critical state,  $y = y_c$  ( $y_c$  being the critical depth). It can be obtained from equation (2.37 a). For a rectangular channel, the critical depth is given by:

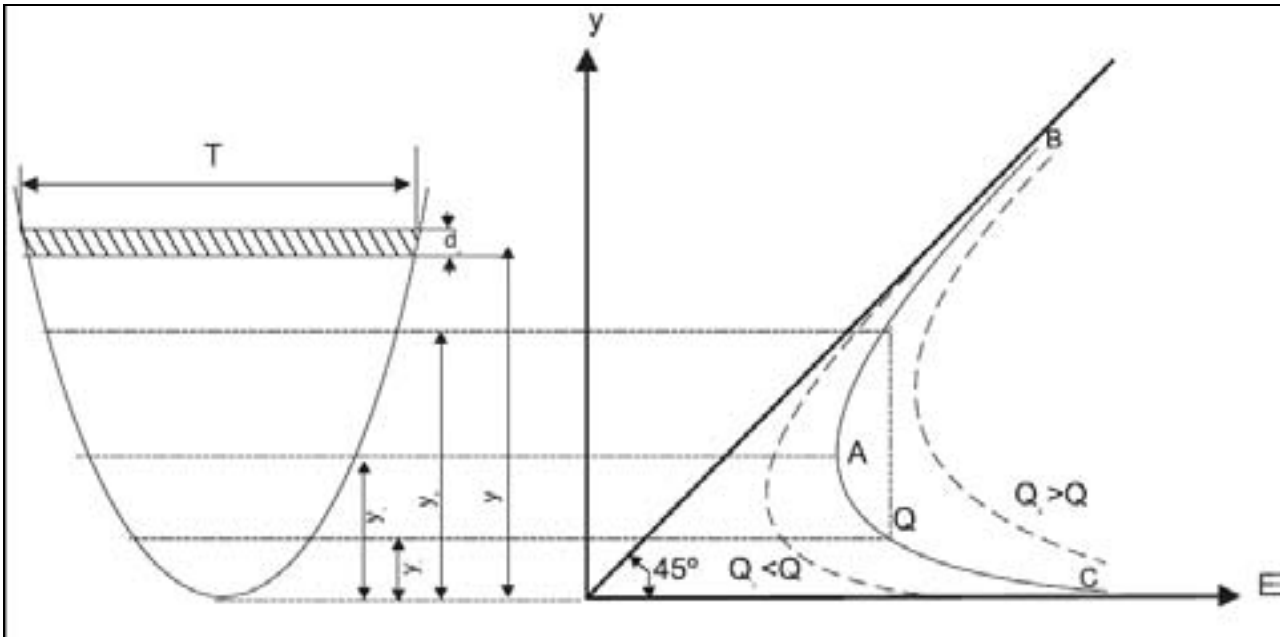


Figure 2-13 Specific energy as a function of flow depth

$$y_c = \sqrt[3]{\frac{Q^2}{gb^2}} = \sqrt[3]{\frac{q^2}{g}} \tag{2.38}$$

where  $q=Q/b$  is the discharge per unit width of the channel. Table 2.5 shows the geometric characteristics of different channel profiles and Table 2.6, taken from Straub (1982) presents the empirical formulae used to estimate  $y_c$ , in non-rectangular channel.

**Example 2.6**

**In a trapezoidal section channel where  $b=6$  m and  $z = 2$ , compute the critical depth flow for a discharge of 17 m<sup>3</sup>/s.**

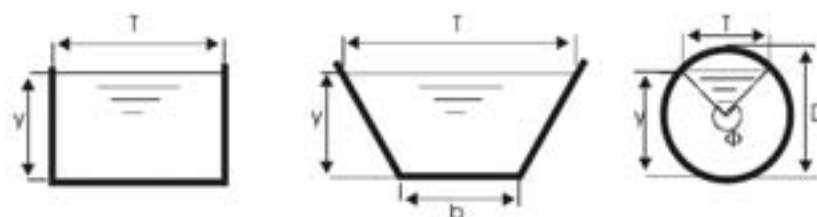
From table 2.6  $\Psi = \alpha Q^2/g = 29.46$  for  $\alpha=1$

The solution is valid provided  $0.1 < Q/b^2 < 0.4$ ; as  $q/b^2 = 0.19$  it is valid

$$y_c = 0.81 \left( \frac{\Psi}{z^{0.75} b^{1.25}} \right)^{0.27} - \frac{b}{z} \Psi = 0.86m$$

The estimation of the critical depth, and the supercritical and subcritical ones, permits the profile of the free surface to be determined, in cases such as, the sudden increase in the slope of a channel, the free surface upstream from a gate and spillways, etc..

Table 2-5 Geometrical characteristics of different channel profiles



Area A	$by$	$(b+zy)y$	$\frac{1}{8}(\Phi - \text{sen}\Phi)D^2$
Wetted perimeter P	$b+2y$	$b + 2y\sqrt{1+z^2}$	$1/2\phi D$
Top width of section T	$b$	$b+2zy$	$2\sqrt{y(D-y)}$
Hydraulic radius R	$\frac{by}{b+2y}$	$\frac{(b+zy)y}{b+2y\sqrt{1+z^2}}$	$\frac{1}{4}\left(1 - \frac{\text{sen}\Phi}{\Phi}\right)D$
Hydraulic depth D	$y$	$\frac{(b+zy)y}{b+2zy}$	$\frac{1}{8}\left(\frac{\Phi - \text{sen}\Phi}{\frac{\text{sen}\Phi}{2}}\right)D$
Section factor	$by^{1.5}$	$\frac{[(b+zy)y]^{1.5}}{\sqrt{b+2zy}}$	$\frac{\sqrt{2}(\theta - \text{sen}\theta)^{1.5}}{32\sqrt{\text{sen}\frac{\theta}{2}}}D^{2.5}$

Table 2-6 Empirical formulae used to estimate  $y_c$ , in typical channel.

$\left(\frac{\Psi}{b^2}\right)^{1/3}$	$0,81\left(\frac{\Psi}{z^{0,75}b^{1,25}}\right)^{0,27} - \frac{b}{30z}$	$\left(\frac{1,01}{d^{0,25}}\right)\Psi^{0,25}$



# Moody Diagram

$$Re_f^{1/4} = \frac{f^{1/2}}{\nu} \left( \frac{2\rho V}{L} \right)^{1/2}$$

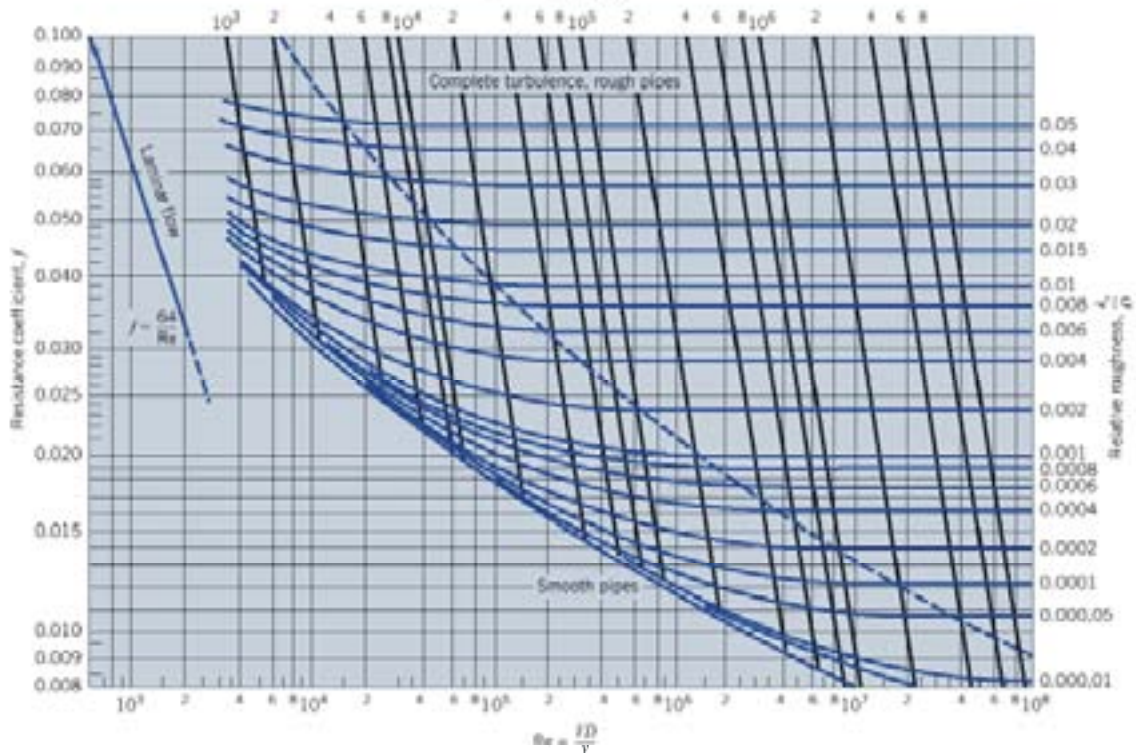


Figure 2-14 Moody's Chart: Friction factors for pipe flow

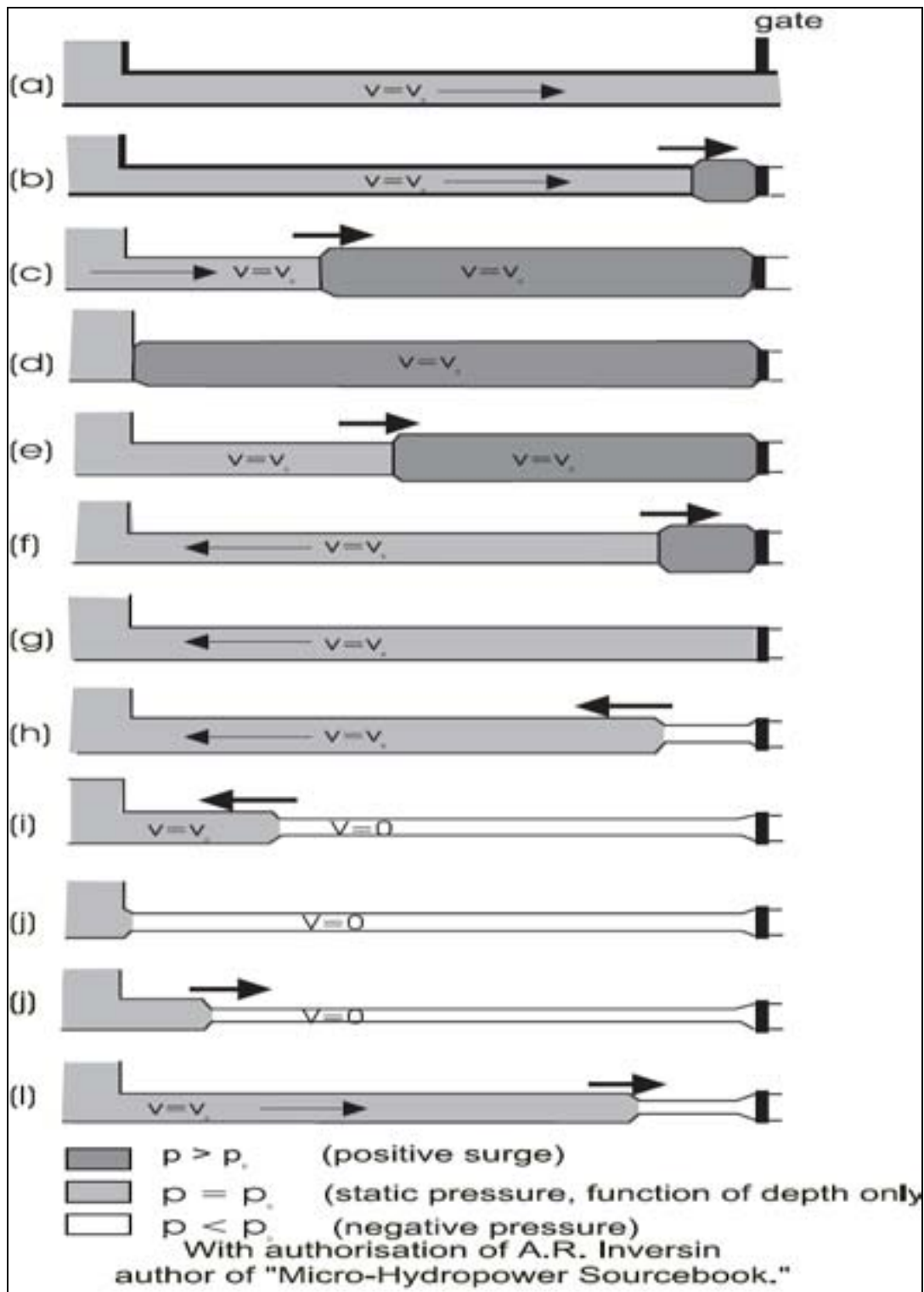


Figure 2-15 Illustration of pressure wave in pipes

## **Bibliography**

1. N.H.C.Hwang and Carlos Hita, "Fundamentals of Hydraulic Engineering Systems", Prentice Hall Inc. Englewood Cliffs, New Jersey 1987
2. F.H. White, "Fluid Mechanics", MacGraw-Hill Inc. USA
3. A. Piqueras, "Evacuación de Broza" (in Castilian), ESHA Info n° 9 summer 1993
4. L. Allievi, The theory of waterhammer, Transactions ASME 1929
5. H. Chaudry. Applied Hydraulic Transients, Van Nostrand Reinhold Co. 1979
6. V.L. Streeter and E.B. Wylie, Hydraulic Transients, McGraw-Hill Book Co., New York 1967
7. J. Parmakian. Waterhammer analysis. Dower Publications, New York 1963
8. R.H. French, "Hidráulica de canales abiertos" (in Castilian), McGraw-Hill/Interamericana de Mexico, 1988
9. V.T. Chow, Open Channel Hydraulics, McGraw-Hill Book Co., New York 1959
10. V.L. Streeter and E.B. Wylie, Fluid Mechanics, McGraw-Hill Book Co., New York 1975
11. A.C Quintela, « Hidráulica » (in Portuguese), Ed. Calouste Gulbenkian Foundation, 1981
12. J. Dubois, "Comportement hydraulique et modélisation des écoulements de surface" (in French),  
Communication LCH n° 8, EPFL, Lausanne 1998.
13. E. Mosonyi, "Water power development", Tome I and II, Akadémiai Kiadó Budapest, 1987/1991

Other references on the topics of this subject :

W.King and E.F. Brater, Handbook of Hydraulics, McGraw-Hill Book Co., New York 1963

R. Silvester, Specific Energy and Force Equations in Open-Channel Flow, Water Power March 1961

---

<sup>i</sup> By Jonas. Rundqvist (SERO), Pedro Manso (EPFL) and Celso Penche (ESHA)

## CHAPTER 3: EVALUATING STREAMFLOW

### CONTENTS

3.	EVALUATING STREAMFLOW .....	44
3.1.	Introduction.....	44
3.2.	Stream flow records .....	45
3.3.	Evaluating stream flows by discharge measurements .....	46
3.3.1.	Velocity-area method.....	46
3.3.2.	Weir method.....	53
3.3.3.	Slope-area method .....	54
3.4.	Stream Flow Characteristics .....	55
3.4.1.	Hydrograph .....	55
3.4.2.	Flow Duration Curves (FDC) .....	55
3.4.3.	Standardised FDC curves.....	56
3.4.4.	FDCs for particular months or other periods .....	58
3.4.5.	Water Pressure or “head” .....	59
3.5.	Residual, reserved or compensation flow .....	61
3.6.	Estimation of plant capacity and energy output.....	61
3.6.1.	How the head varies with the flow and its influence on the turbine capacity .....	63
3.6.2.	Peaking operation.....	64
3.7.	Firm energy.....	65
3.8.	Floods.....	65
3.8.1.	Flood Control Design.....	65
3.8.2.	Statistical analysis of flood data .....	66
3.8.3.	Hydrological modelling of the catchment area.....	68
	Bibliography .....	69

### LIST OF FIGURES

Figure 3-1	Schematic layout of a hydro development.....	44
Figure 3-2	Measuring the river stage, definitions.....	46
Figure 3-3	Rating curve .....	48
Figure 3-4	Measuring the cross-sectional area .....	49
Figure 3-5	Conductivity time curve.....	52
Figure 3-6	Discharge measurements using weirs and notches .....	53
Figure 3-7	Example of hydrograph.....	54
Figure 3-8	Example of a flow duration curve (FDC) .....	55
Figure 3-9	Example of FDC with logarithmic scale.....	56
Figure 3-10	Example of standardised FDCs.....	57
Figure 3-11	Conveyance system (example 3.1).....	59
Figure 3-12	Residual flow .....	61
Figure 3-13	Example of turbine efficiency as a function of flow.....	63
Figure 3-14	Variation of net head vs. river flow .....	64
Figure 3-15	Components of hydrological model.....	68

**LIST OF TABLES**

Table 3-1 Typical values of Manning's n for watercourses ..... 54  
Table 3-2 Minimum technical flow of turbines ..... 62  
Table 3-3 Typical design flood criteria..... 66  
Table 3-4 Probability of occurrence ..... 66

**LIST OF PHOTOS**

Photo 3-1 Gauging station in a river ..... 47  
Photo 3-2 Current meters ..... 50

### 3. EVALUATING STREAMFLOW<sup>i</sup>

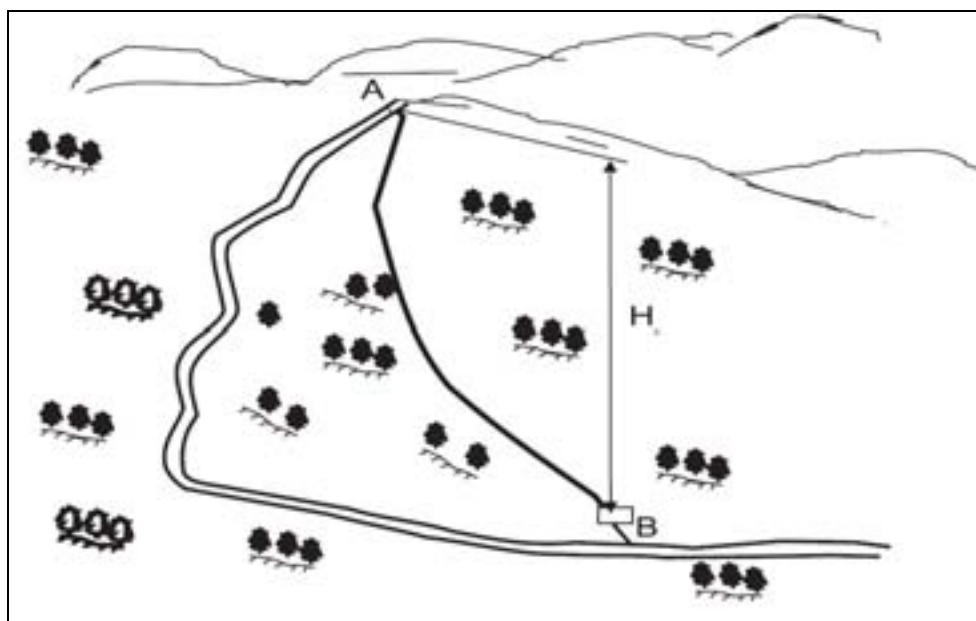
#### 3.1. Introduction

All hydroelectric generation depends on falling water. This makes hydropower extremely site dependent. First of all, a sufficient and dependable stream flow is required. Secondly, the topographic conditions of the site must allow for the gradual descent of the river in a river stretch be concentrated to one point giving sufficient head for power generation. This head can be created by dams or by leading the water in parallel to the river in a waterway with low head losses compared to the natural stream, or very often, by a combination of both.

Planning for the exploitation of a river stretch or a specific site is one of the more challenging tasks that face a hydropower engineer, since there are an unlimited number of practical ways in which a river or site can be exploited.

The hydropower engineer has to find the optimum solution for plant configuration, including dam type, water conveyance system, installed generating capacity, location of various structures etc. The success of the hydropower engineer depends on experience and an almost “artistic” talent, since a strictly mathematical optimisation approach is impossible, due to the number of possibilities and site-specific conditions.

When a site has been identified as topographically suitable for hydropower, the first task is to investigate the availability of an adequate water supply. For an ungauged watercourse, where observations of discharge over a long period are not available, it involves the science of hydrology, the study of rainfall and stream flow, the measurement of drainage basins, catchment areas, evapotranspiration and surface geology.



**Figure 3-1 Schematic layout of a hydro development**

Figure 3.1 illustrates how the water flowing from point A to point B, with elevations  $Z_A$  and  $Z_B$ , loses potential energy corresponding to the drop in elevation. This loss of potential energy occurs regardless of the path along the watercourse or via an open canal, penstock and turbine. The potential energy lost can be converted to power lost according to the equation:

$$P = Q \cdot H_g \cdot \gamma$$

Where:

P is the power in kW lost by the water

Q is the flow in m<sup>3</sup>/s

H<sub>g</sub> is the gross head in m, = Z<sub>A</sub> – Z<sub>B</sub>, and

γ is the specific weight of water, (9.81 kN/m<sup>3</sup>).

The water can follow the riverbed, losing power through friction and turbulence resulting in a marginal rise in the temperature of the water. Or it can flow from A to B through an artificial conveyance system with a turbine at its lower end. In this case the power will be used mainly for running a turbine, and a smaller part of the power is lost in friction in the conveyance system. In the latter case it is the power lost in pushing through the turbine that will be converted to mechanical energy and then, by rotating the generator, to produce electricity.

The objective is to reduce construction costs while conserving the maximum amount of power available to rotate the generator. To estimate the water potential one needs to know the variation of the discharge throughout the year and how large the gross available head is. In the best circumstances the hydrologic authorities would have installed a gauging station in the stretch of stream under consideration, and stream flow time series data would have been gathered regularly over several years.

Unfortunately, it is rather unusual for regular gauging to have been carried out in the stretch of river where the development of a small hydro scheme is proposed. If, however, it does happen, then it will suffice to make use of one of several approaches that can be used to estimate the long-term average annual flow and the flow duration curve for the stretch in question (these approaches will be explained later).

Whether or not regular gauging has taken place, the first step is to do some research, to ascertain if there are stream flow records for the stretch of river in question. If not, then in other stretches of the same river or a similar nearby river that permits the reconstitution of the time series for the referred stretch of river.

### **3.2. Stream flow records**

In Europe, stream flow records can be obtained from national hydrological institutes. These stream flow records can be of several different types, each useful for the evaluation of the generating potential of the considered site. These include:-

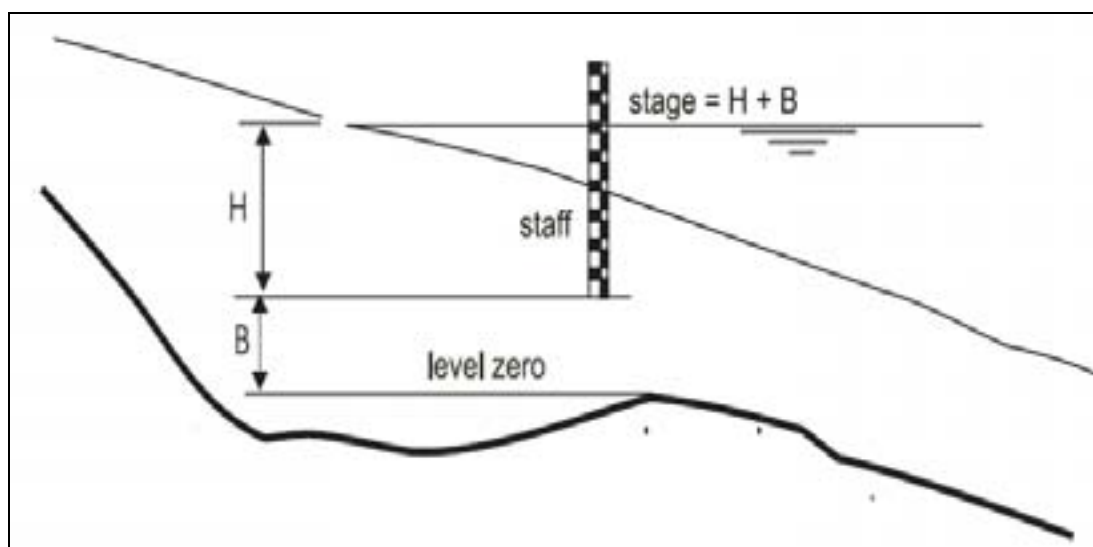
- Measured stream flow data for a number of gauged sites
- Stream flow characteristics for these sites such as mean flow and flow duration curves (both expressed as actual flow and generalised as runoff per unit area of the catchment)
- Runoff maps, etc

There is a United Nations organisation, the “World Meteorological Organisation”, with a hydrologic information service (INFOHYDRO) whose objective is to provide information regarding:

- National and international (governmental and non-governmental) organisations,
- Institutions and agencies dealing with hydrology;
- Hydrological and related activities of these bodies;

- Principal international river and lake basins of the world;
- Networks of hydrological observing stations of countries - numbers of stations and duration of records;
- National hydrological data banks - status of collection, processing and archiving of data;
- International data banks related to hydrology and water resources.

Further information can be obtained at [www.wmo.ch](http://www.wmo.ch) (At the date of printing, the INFOHYDRO database was going through a major revision and was not available)



**Figure 3-2 Measuring the river stage, definitions**

### **3.3. Evaluating stream flows by discharge measurements**

If appropriate stream flow time series cannot be found, the discharge should preferably be directly measured for at least a year. A single measurement of instantaneous flow in a watercourse is of little use. To measure the discharge several methods are available:

#### **3.3.1. Velocity-area method**

This is a conventional method for medium to large rivers, involving the measurement of the cross sectional area of the river and the mean velocity of the water through it. It is a useful approach for determining the stream flow with a minimum effort. An appropriate point must be selected on a relatively straight, smoothly flowing portion of the river to be gauged (figure 3.2).

The river at this point should have a uniform width, with the area well defined and clean. As discharge varies, the top water level (termed the stage of the river) rises and falls. The stage is observed daily at the same time each day on a board - marked with metres and centimetres. In modern gauging stations, instead of a board, that requires regular observations, any one of several water-level measurement sensors is available which automatically register the stage. To calibrate the stage observations or recordings, periodic discharge measurements from the lowest to the highest are made over a time period of several months. Photo 3.1 shows a gauging station in a river.





**Photo 3-1 Gauging station in a river**

The correlation stage-discharge is called a rating curve (figure 3.3) and permits the estimation of the river discharge by reading the river stage. To draw this curve, both the stage and the discharge must be simultaneously read. It is strongly recommended that to begin measuring the low flows, one should use the data to draw a curve that correlates the flows and the 'n' Manning coefficient. Later on the river slope-area method (section 3.3.3) can be used to estimate the high flows, which are often impossible to measure with the other methods.

When a rating curve has been graphically established, based on a number of readings, its mathematical formulation can be readily derived, which facilitates interpretation of the stage readings. The rating curve (figure 3.3) is represented by the function:-

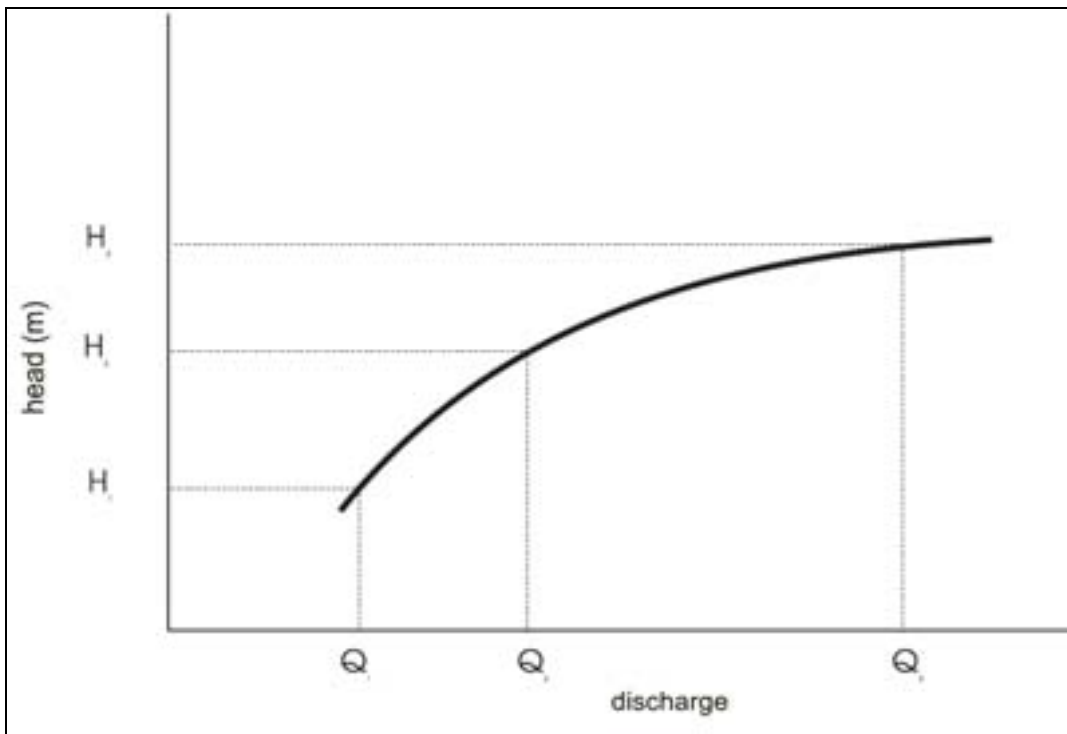
$$Q = a (H+B)^n \quad (3.1)$$

Where  $a$  and  $n$  = constants  
 $H$  = river stage as measured or recorded  
 $B$  = correction factor to get the actual level

To compute  $B$  (see figure 3.2) the data corresponding to two discharges should be noted, such as

$$Q_1 = a (H_1+B)^n$$

$$Q_2 = a (H_2+B)^n$$



**Figure 3-3 Rating curve**

By introducing a third “factual” reading  $H_3$  vs.  $Q_3$ , where  $Q_3$  (indexes in figure 3.3 are not representative) is defined as the square root of the product of  $Q_1$  and  $Q_2$ , and the corresponding  $H_3$  is taken from the graphical representation of the rating curve  $Q_3$ , this can be expressed as:-

$$Q_3 = \sqrt{Q_1 \cdot Q_2} = a(H_3 + B)^n = \sqrt{a(H_1 + B)^n \cdot a(H_2 + B)^n}$$

consequently:

$$(H_3 + B)^2 = (H_1 + B) \cdot (H_2 + B)$$

and therefore:

$$B = \frac{H_3^2 - H_1 H_2}{H_1 + H_2 - 2H_3} \tag{3.2}$$

There are ISO recommendations for the correct use of this technique.

**Measuring the cross-sectional area**

To compute the cross-sectional area of a natural watercourse it should be divided into a series of trapezoids (figure 3.4). Measuring the trapezoid sides, by marked rules, illustrated in figure 3.4, the cross-section would be given by:-

$$S = b \frac{h_a + h_2 + \dots + h_n}{n} \tag{3.3}$$

### Measuring the velocity

Since the velocity both across the flow and vertically through it is not constant, it is necessary to measure the water velocity at a number of points to obtain a mean value. There are several ways of doing this, two of which are discussed below.

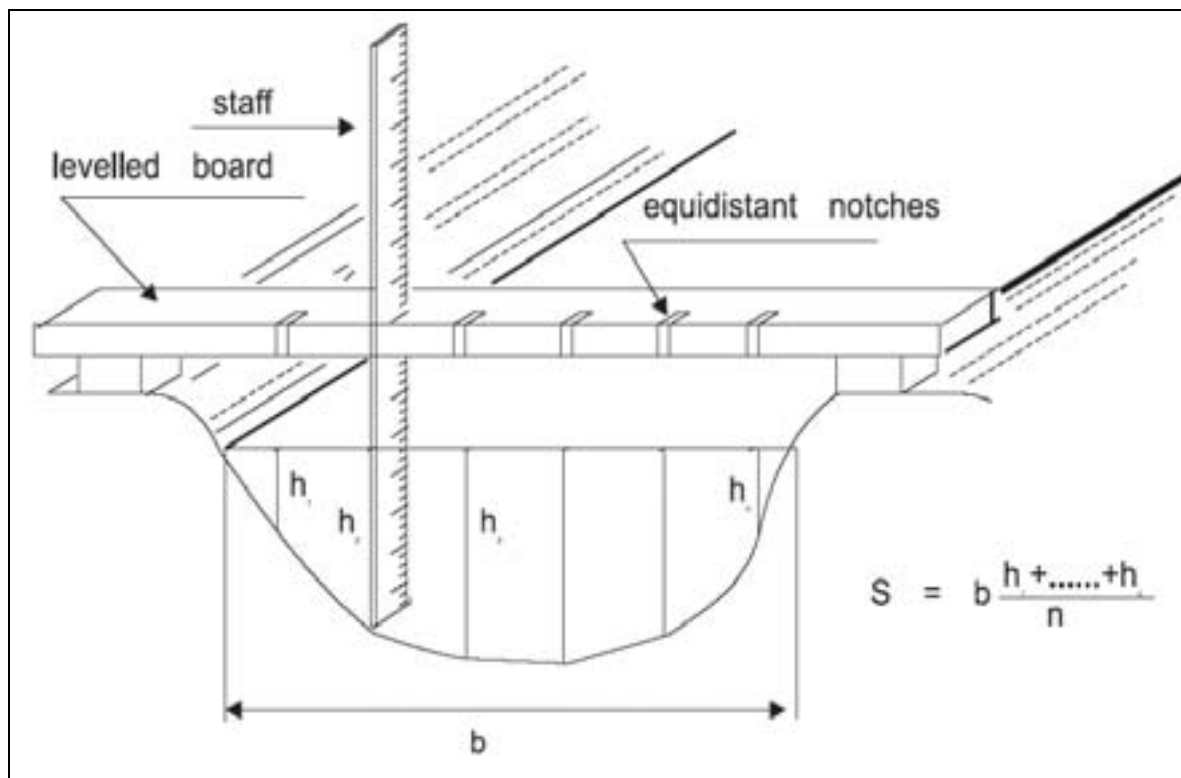


Figure 3-4 Measuring the cross-sectional area

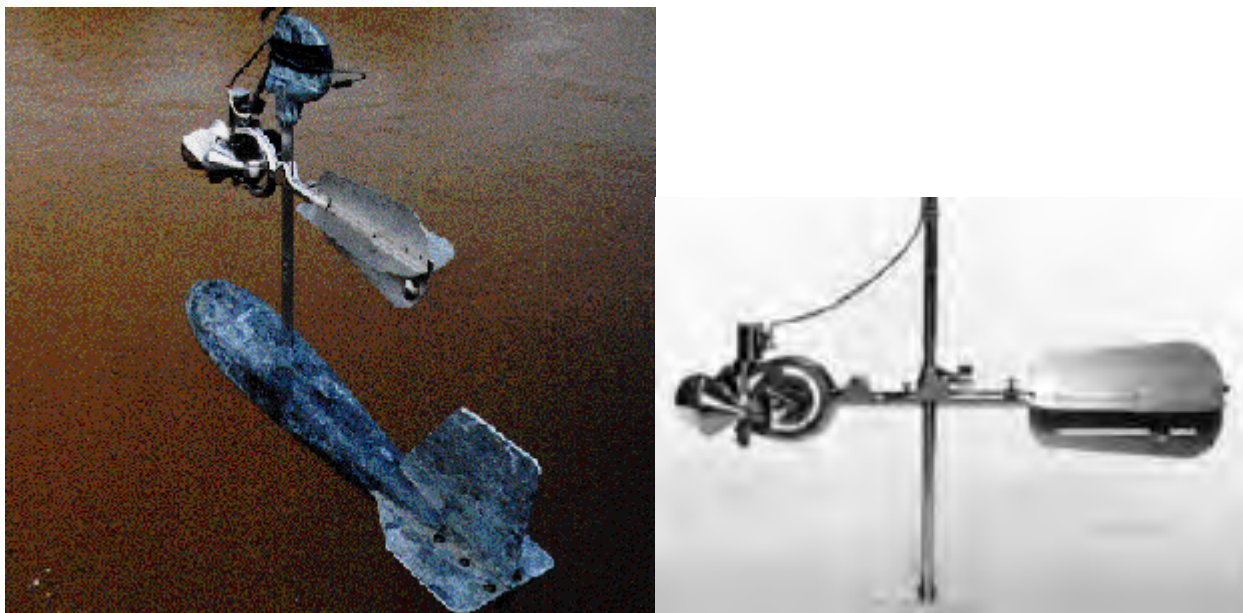
#### By float

A floating object, which is largely submerged (for instance a wood plug or a partially filled bottle) is located in the centre of the stream flow. The time  $t$  (seconds) elapsed to traverse a certain length  $L$  (m) is recorded. The surface speed (m/s) would be the quotient of the length  $L$  and the time  $t$ . To estimate the mean velocity, the above value must be multiplied by a correction factor that may vary between 0.60 and 0.85 depending on the watercourse depth and their bottom and riverbank roughness (0.65 is a well accepted value). The accuracy of this method is dependant on the range of correction factor.

#### By mechanical current-meter

A current-meter is a fluid-velocity-measuring instrument. Current meters are classified in two types:-  
 Vertical axis rotor with cups: This type of instrument has a circle of small conical cups, disposed horizontally which rotate about the suspension axis. (Photo 3.2 right photo) These current meters operate in lower velocities than the horizontal axis rotor types, and have the advantage of bearings being well protected from silty waters. The rotor can be repaired in the field.

Horizontal axis rotor with vanes (propeller): A small propeller rotates about a horizontal shaft, which is kept parallel to the stream by tail fins. (Photo 3.2 left photo) The instrument is weighted to keep it as directly as below the observer as possible. This rotor has the advantage of being less likely to disturb the flow around the measuring point and also for being less likely to become entangled by debris.



**Photo 3-2 Current meters**

Each revolution of the propeller is recorded electrically through a cable to the observer and the number of revolutions is counted by the observer, or automatically by the instrument itself, over a short period (say 1 or 2 minutes). These observations are converted into water velocities from a calibration curve for the instrument (modern instruments, with microprocessor technology will compute this and display it almost immediately). By moving the meter vertically and horizontally to a series of positions (whose coordinates in the cross-section are determined), a complete velocity map of the cross-section can be drawn and the discharge through it calculated.

In the case of medium to large rivers, observations are made by lowering the meter from a bridge, however, if the bridge is not single-span there will be divergence and convergence of the streamlines caused by the piers, and this can cause considerable errors. In many instances, however, the gauging site, which should be in as straight and uniform a reach of the river as possible, will have no bridge. In such cases, particularly if it is deep and in flood, a cable to hold a stable boat must be provided, together with a lighter measuring cable to determine horizontal position in the cross-section.

Since the drag on a boat, with at least two occupants and suspended current-meter, is considerable, a securely fastened cable should be used. The presence of suitable large trees at a particular site often necessitates its choice for this reason. Alternatively, for very large rivers, cableways are sometime used to suspend the meter, directly from a cable car, the instrument in this latter case being positioned by auxiliary cables from the riverbanks or from the cable car itself.

Depths should always be measured at the time of velocity observation since a profile can change appreciably during flood discharges. Observers should also remember such elementary rules as to observe the stage before and after the discharge measurement, and to observe the water slope by accurate levelling to pegs at the water level as far upstream and downstream of the gauging site as is practicable, up to (say) 500m in each direction.

As water velocities increase in high floods the weighted current meter will be increasingly swept downstream on an inclined cable. The position of a meter in these circumstances can be found reasonably accurately if the cable angle is measured. Ballast can be increased but only within limits.

Rods can be used to suspend the meters but a rigid structure in the boat will then be required to handle the rods, calling for a stable platform on a catamaran-type of craft. Rod vibration and bending are common in deep rivers unless large diameter rods are employed, in which case the whole apparatus is getting very heavy and unmanageable.

### **By electro-magnetic current-meter**

An electro-magnetic (e/m) current-meter is an electrical induction-measurement instrument, with no moving parts, mounted in a totally enclosed streamlined probe. The probe can be mounted on rods and held at various depths or suspended on a cable.

The e/m meter has the advantages of being smaller and having a wider measurement range than the propeller meters. It is particularly useful at very low velocities when propeller meters become erratic. Its sensitivity and lower vulnerability to fouling from weeds and debris make it attractive for use in heavily polluted or weedy streams.

Each unit is provided with a surface control box with a digital display and dry-cell batteries. A set of stainless steel wading rods is also standard equipment. Latest models have built-in battery-charger circuits.

It will be appreciated that since each river is unique, a careful assessment of its width, depth, likely flood velocities, cable-support facilities, availability of bridges, boats, etc. needs to be made before a discharge measurement programme can begin.

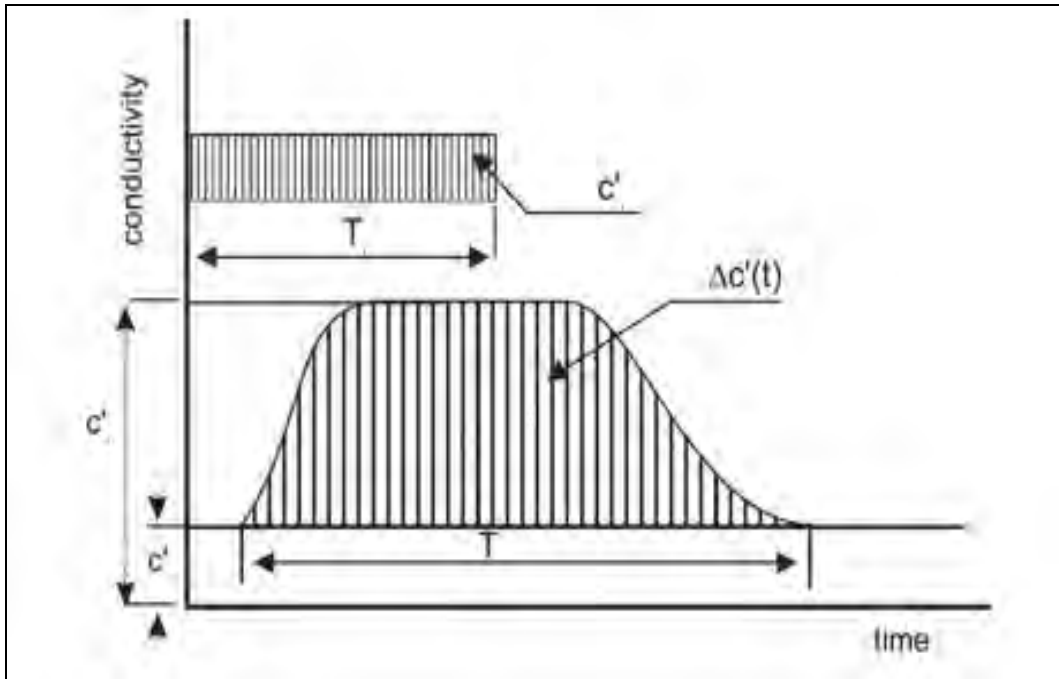
The discharge at the chosen measuring point is best obtained by plotting each velocity observation on a cross section of the gauging site with an exaggerated vertical scale. Isovels (velocity profiles – contours of equal velocity) are then drawn and the included areas measured by a planimeter. Alternatively, the river may be subdivided vertically into sections and the mean velocity of each section applied to its area. In this method the cross-sectional area of any one section, where measurements, are taken should not exceed 10 per cent of the total cross-sectional area.

A check should always be made using the slope-area method of section 3.3.4 and a value obtained for the Manning's number “n”. In this way knowledge of the n values of the river at various stages will be built up and this may prove most valuable for subsequently extending the discharge-rating curve.

To ensure uniformity in the techniques of current-meter gauging, ISO has published a number of recommendations.

### **By dilution methods.**

Dilution gauging is particularly suited to small turbulent streams where depths and flows are inappropriate for current metering, and flow structures would be unnecessarily expensive. The method involves the injection of a chemical into the stream and the sampling of the water some distance downstream after complete mixing of the chemical in the water has occurred. The chemical can either be added by constant-rate injection until the sampling downstream reveals a constant concentration level, or administered in a single dose as quickly as possible, known as “gulp injection”. In the latter case, samples over a period of time disclose the concentration-time correlation. In both cases the concentration of chemical in the samples is used to compute the dilution, and hence, the discharge of the stream can be obtained.



**Figure 3-5 Conductivity time curve**

Analysis of the samples is by an automated colorimetric procedure that estimates the concentration of very small amounts of chromium compound by comparing with a sample of the injection solution. The equipment is expensive and somewhat specialised.

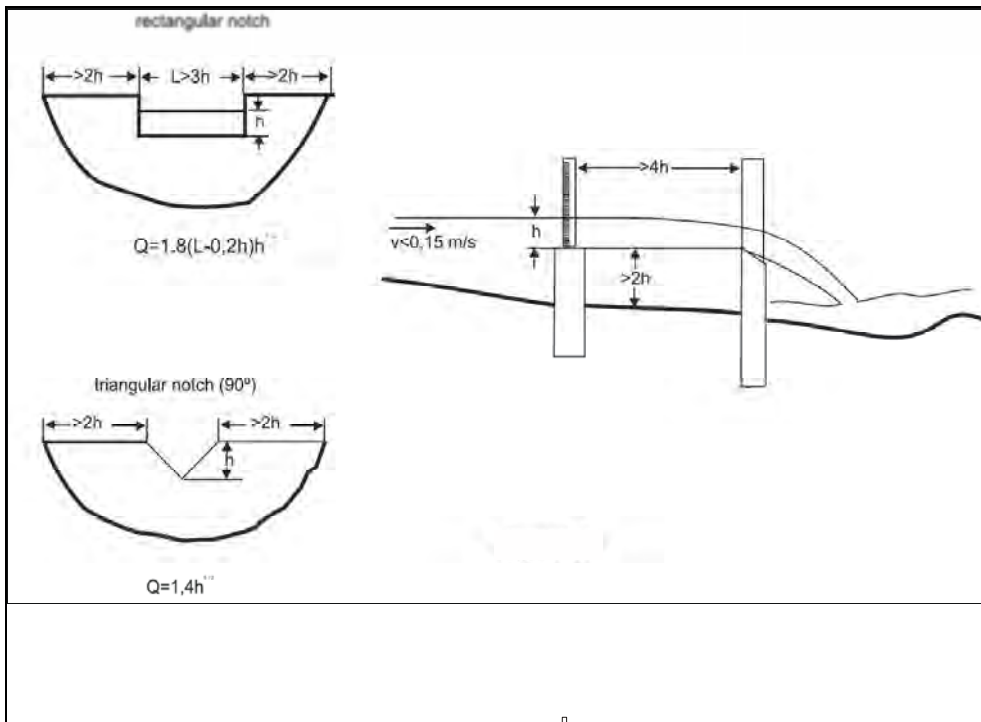
Recent developments have substituted the above procedures by a method developed by Littlewood<sup>7</sup>, requiring only simple and relatively cheap equipment. The method depends on the electrical conductivity of solutions of common salt (NaCl) in the stream water and is a version of the relative-dilution gauging method developed by Aastad and Soggen.

The discharge is measured by gradually releasing a known volume (V) of a strong salt solution (c<sup>1</sup>) into the stream at a known rate (q), and measuring, at short intervals, the change in conductivity of the water at the downstream end of the mixing length. It is then possible to plot a conductivity-time curve, along a time T as in figure 3.5. The average of the ordinates, of this curve, represent the average of the difference in conductivity, between the salt solutions and the stream water, upstream from the injection point. If a small volume, v, of the particular strong solution is added to a large volume V\* of the stream water, and the differences in conductivity Δc\* are measured, the discharge will be then given by the equation:

$$Q = \frac{V}{T_2} \times \frac{V^*}{v} \times \frac{\Delta c^*}{\Delta c'} \tag{3.5}$$

where:

- v = volume of injection solution
- T<sub>2</sub> = duration of solute wave (s)
- V = volume of the strong solution added to a larger
- V\* = volume of stream water
- Δc\* = change in conductivity (ohm-1) consequence of the dilution of v in V\*
- Δc' = ordinate's average curve conductivity-time



**Figure 3-6 Discharge measurements using weirs and notches**

3.3.2. Weir method

If the watercourse being developed is reasonably small (say  $< 4$  m<sup>3</sup>/s) then it may be possible to build a temporary weir. This is a low wall or dam across the stream/river to be gauged with a notch through which all the water may be channelled. Many studies have established accurate formulae for the discharge through such notches. A simple linear measurement of the difference in level between the upstream water surface and the bottom of the notch is sufficient to quantify the discharge. However, it is important to measure the water surface level some distance back from the weir (at least four times the depth over the base of the notch) and to keep the notch free of sediment and the edge sharp and chamfered on the downstream side of the top of the weir/notch.

Several types of notches can be used:-

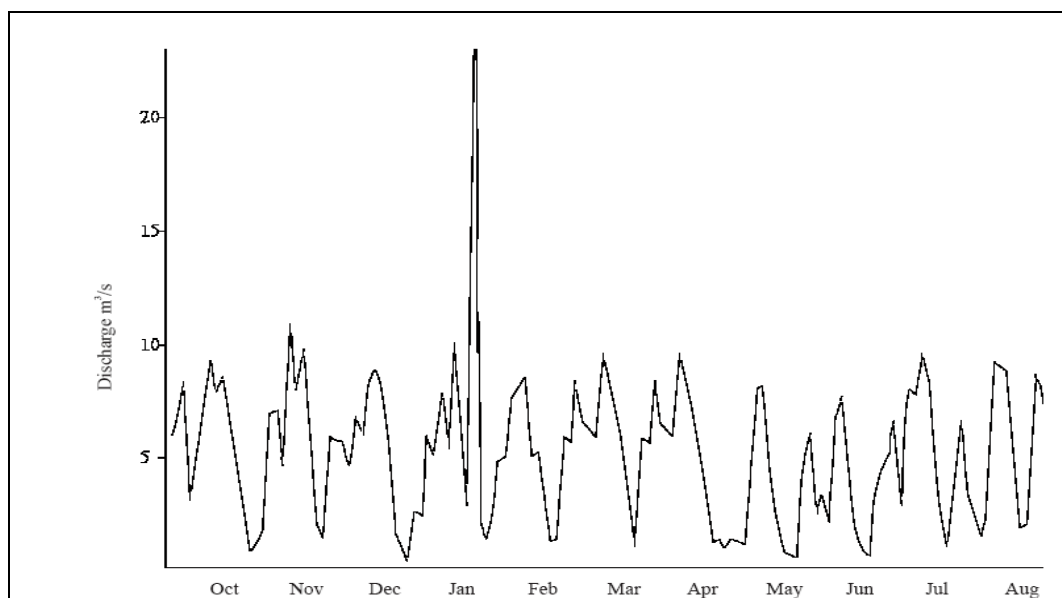
- Rectangular,
- V-notch
- Trapezoidal.

The V-notch is the most accurate at very low discharges but the rectangular or trapezoidal types are capable of a much wider range of flows. The actual notches may be metal plates or planed hardwood with sharp edges, built to the dimensions of figure 3.6.

Another fairly accurate method is to construct a “Flume”. A “Flume” is where a stream is channelled through a particular geometrically shaped regular channel section for some distance before entering a length of different cross-section, usually made so by side contraction or steps in the bed, generally in the shape of a “Venturi”. These structures have the advantage over weirs in that they do not obstruct the flow or “ponding” of the water upstream, they can also be very accurate and provide a permanent gauging station.

To ensure uniformity in the techniques of current-meter gauging ISO has published various recommendations. The catalogue with ISO recommendations can be obtained at:

<http://www.iso.ch/iso/en/CatalogueListPage.CatalogueList?ICS1=17&ICS2=120&ICS3=20>



**Figure 3-7 Example of hydrograph**

3.3.3. Slope-area method

This method depends on some of the hydraulic principles described in Chapter 2 and is useful for high flows where other methods are impractical. It presupposes that it is practical to drive in pegs or make other temporary elevation marks at the water-surface level (upstream and downstream of the discharging site) at the time the flow measurements are taken. These marks can subsequently be used to establish the water slope (S). Cross-sectional measurements are taken to establish the area (A) and hydraulic radius of the section (R). Once these parameters are known the discharge is computed by the Manning formula

$$Q = \frac{A \cdot R^{2/3} \cdot S^{1/2}}{n} \tag{3.6}$$

This method is sometimes criticised because of its dependence on the value of n. Since n for natural streams is about 0.035, an error in n of 0.001 gives an error in discharge of 3 per cent. This error may be partially reduced by plotting n against stage for all measured discharges, so that the choice of n for high stages is not arbitrary but is taken from such a plot. If a high flood slope can be measured, then this method may well be the best one for such flows. Typical values of Manning's n for watercourses and common pipe materials are given Table 3.1

**Table 3-1 Typical values of Manning's n for watercourses**

Watercourses	n
Natural stream channels flowing smoothly in clean conditions	0.030
Standard natural stream or river in stable conditions	0.035
River with shallows and meanders and noticeable aquatic growth	0.045
River or stream with rods and stones, shallows and weedy	0.060



### 3.4. Stream Flow Characteristics

A programme of stream gauging, at a particular site over a period of years, will provide a table of discharges that, to be of any use, has to be organised into a usable form.

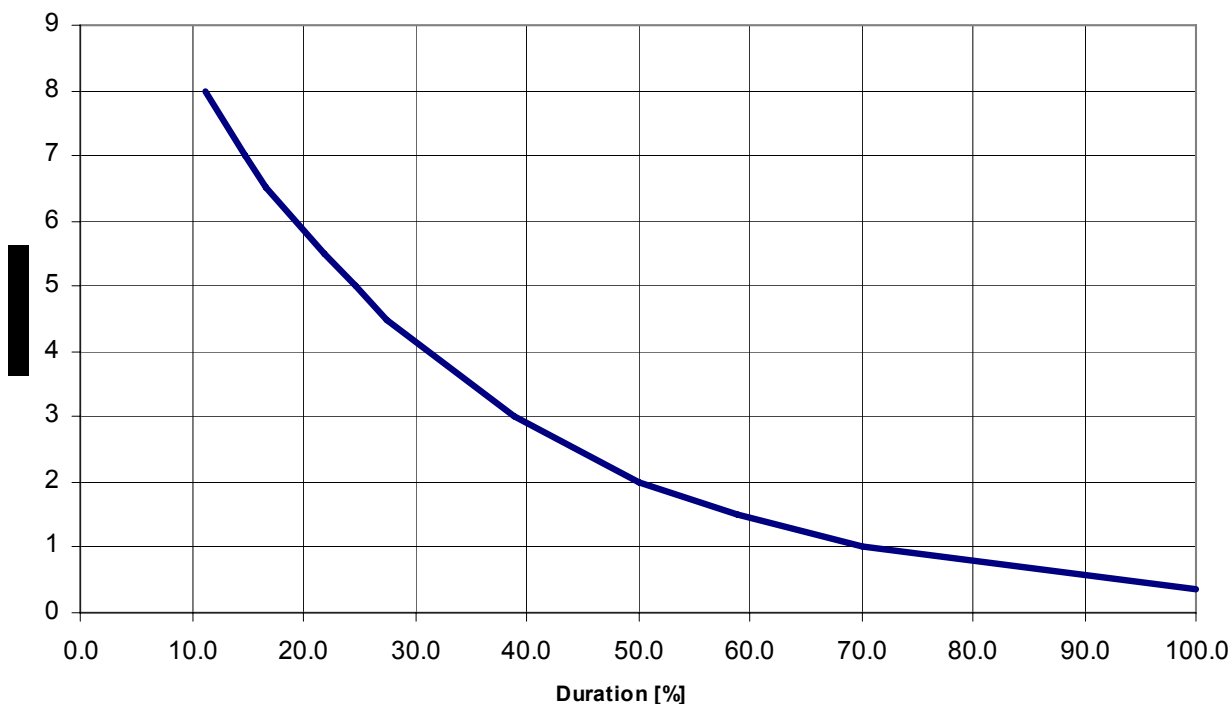


Figure 3-8 Example of a flow duration curve (FDC)

#### 3.4.1. Hydrograph

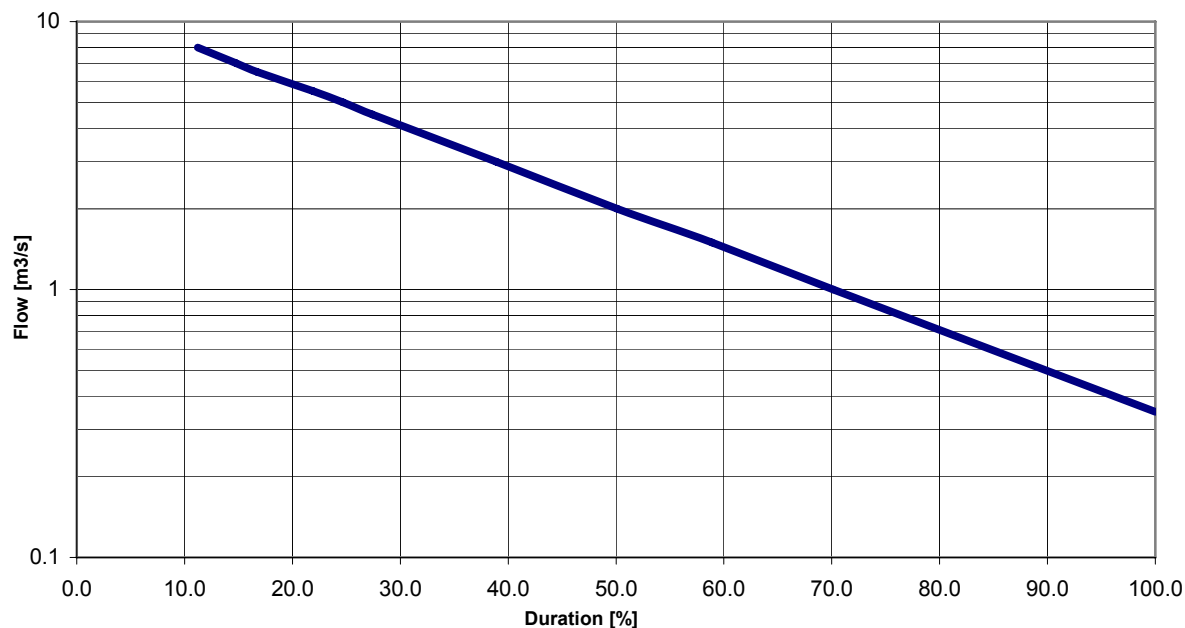
One way of doing this is to plot them sequentially in the form of a hydrograph, which shows discharge against time, in chronological order (see figure 3.7).

#### 3.4.2. Flow Duration Curves (FDC)

Another way of organising discharge data is by plotting a flow duration curve (FDC) An FDC shows for a particular point on a river the proportion of time during which the discharge there equals or exceeds certain values. It can be obtained from the hydrograph by organising the data by magnitude instead of chronologically. If the individual daily flows for one year are organised in categories as shown below:-

	No of days	% of the year
Flows of 8.0 m <sup>3</sup> /s and greater	41	11.23
Flows of 7.0 m <sup>3</sup> /s and greater	54	14.9
Flows of 6.5 m <sup>3</sup> /s and greater	61	16.8
Flows of 5.5 m <sup>3</sup> /s and greater	80	21.8
Flows of 5.0 m <sup>3</sup> /s and greater	90	24.66
Flows of 4.5 m <sup>3</sup> /s and greater	100	27.5
Flows of 3.0 m <sup>3</sup> /s and greater	142	39
Flows of 2.0 m <sup>3</sup> /s and greater	183	50
Flows of 1.5 m <sup>3</sup> /s and greater	215	58.9
Flows of 1.0 m <sup>3</sup> /s and greater	256	70
Flows of 0.35 m <sup>3</sup> /s and greater	365	100

If the above figures are plotted then a graph like figure 3.8 will be obtained, which represents the ordinates of figure 3.7 arranged in order of magnitude instead of chronologically.



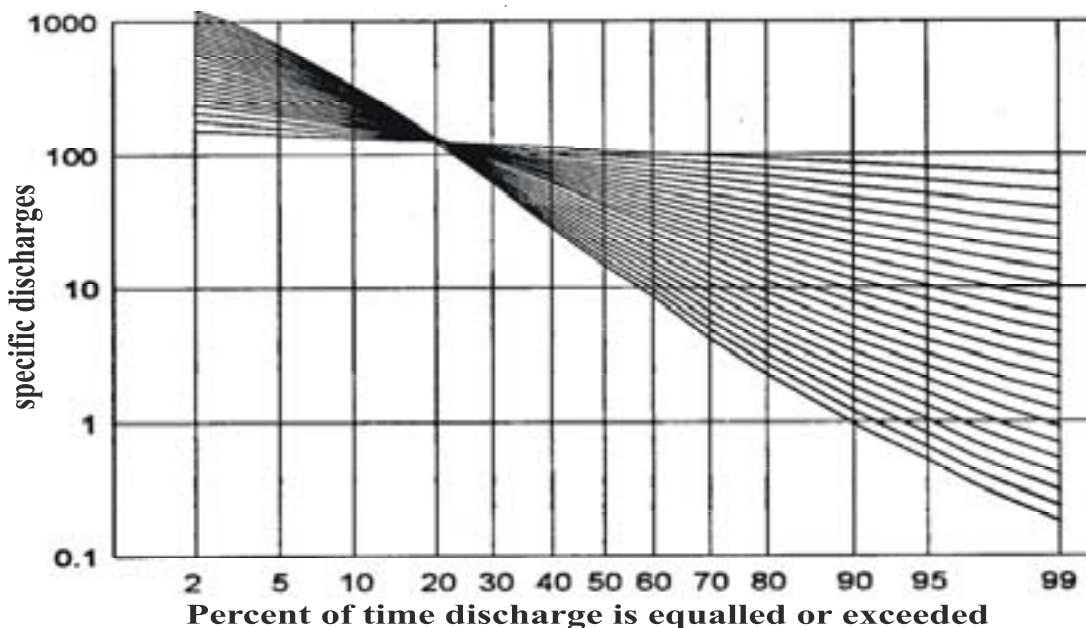
**Figure 3-9 Example of FDC with logarithmic scale**

Most gauging stations (in the EU) are computerised, the easiest way to derive a FDC is to transpose the digital data to a spreadsheet, sorting them in descending order, and then by hand or by using a simple macro, classify the data as in the above table. Once done, the same spreadsheet, using its graphic building capability will draw the curve FDC (like the one drawn in figure 3.8).

For many rivers the ratio of peak to minimum discharges may be two or more orders of magnitude and FDCs for points on them are often more conveniently drawn with the (Q) ordinate to a logarithmic scale, and a normal probability scale used for the frequency axis. On these, logarithmic graphs, the discharges are distributed, such that the FDC plots as a straight line. Figure 3.9 represents the graph in figure 3.8 with the vertical axis in logarithmic scale.

### 3.4.3. Standardised FDC curves

FDCs for different rivers can be compared by presenting them in a standardised way. The discharges are divided firstly by the contributing catchment areas and secondly by weighted average annual rainfall over the catchment areas. The resulting discharges, in m³/s or litres /s, per unit area, per unit annual rainfall (typically m³/s/km²/m) can then be compared directly. Figure 3.10 shows twenty FDCs corresponding to catchment areas of different geological composition, drawn to a double logarithmic scale. A collection of regional flow-duration curves shows the effect of a basin’s superficial geology on the shape of the curves. If the flow duration curves of different catchments are standardised by the catchments mean flow, certain low flow statistics, such as Q95 can be used to describe the whole flow duration curve.



**Figure 3-10 Example of standardised FDCs**

Another method for standardising FDCs is to express  $Q$  in terms of  $Q/Q_m$ , where  $Q_m$  is the mean flow. The use of such a non-dimensional ordinate allows all rivers, large and small, to be compared on the same graph. If sufficient records are available from neighbouring rivers of similar topographical character in a similar climate, these methods can be very useful in evaluating stream flows at ungauged sites. If we know the FDC for another stretch of the same river, it will be possible to extrapolate it using the ratio of areas of the respective catchment basins.

When there are no flow records for a particular location it is necessary to proceed from first principles. Rainfall data is normally available from national agencies on an annual-average basis, but often only on a fairly small scale. Therefore, attempts should always be made to find local records, which will indicate seasonal variation. Failing that, a standard rain gauge should be installed in the catchment area, as soon as the studies are being considered. Even one year's records will help in the production of a synthesised FDC.

The first step is to estimate the mean annual flow  $Q_m$  [also referred to average daily flow (ADF)].

In UK the mean flow is estimated using a rainfall catchment water balance methodology, the long term average annual runoff of rainfall can be assumed to be equal to the difference between standard average annual rainfall (SAAR) and actual evaporation (AE). Catchment values of SAAR and potential evaporation are estimated from the rainfall and potential evaporation (PE) maps.

Actual evaporation is estimated from potential evaporation using a scaling factor  $r$ , where  $r$  increases with SAAR and hence increasing water availability. For catchments with annual average rainfall in excess of 850mm per year, it is assumed that actual evaporation is equal to potential. This relationship between SAAR is given by:

$$r = 0.00061 \times \text{SAAR} + 0.475 \text{ for SAAR} < 850 \text{ mm}$$

$$r = 1.0 \text{ for SAAR} > 850 \text{ mm}$$

$$\text{Actual evaporation is calculated using: } AE = r \times PE$$

The average runoff depth (AARD in millimetres) over the catchment area (AREA in km<sup>2</sup>) is converted to mean flow in m<sup>3</sup>/s by:

$$Q_m = (\text{AARD} \times \text{AREA}) / 31536$$

Although the mean annual flow gives an idea of a stream's power potential, a firmer knowledge of the stream's flow regime, as obtained from a flow duration curve, is needed. The flow duration curve depends on the type of soil on which the rain falls. If it is very permeable (sand) the infiltration capacity will be high and the groundwater will be a large proportion of flow in the stream. If it is impermeable (rock) the opposite will be the case. The catchments of high permeability and large groundwater contributions will therefore tend to have more regular discharges with less fluctuating flow than rocky catchments, where the variations will be great and will reflect the incidence of rainfall to a much greater extent.

In UK, for instance, soils have been categorised into 29 discrete groups that represent different physical properties and hydrological response. The classification system is referred to as the Hydrology of Soil Types (HOST) classification. By measuring the areas of each of these categories, within the catchment, as a proportion of the whole, the BFI (Base Flow Index) can be computed. Knowing the BFI of the catchment, a standardised FDC can be selected from figure 3.11. Multiplying the ordinates of the selected FDC by the catchment  $Q_m$ , the particular flow duration curve of the site is obtained.

In Spain, the distribution of the soils has been identified from the Soil Map of the European Communities (CEC, 1985), which is based on the FAO/UNESCO Soil Classification of the World. Nineteen soils are represented within the gauged catchments considered in the study.

There are actually many watershed models that permit calculation of the runoff for a certain catchment basin taking into account the average daily rainfall, the potential evapotranspiration, the soil composition, the basin slope and area, the stream length, and other parameters. All those programs allow an analysis of the snowmelt and its contribution to the discharge, and also the creation of flood inundation maps, flood depths maps and flood impact maps.

#### 3.4.4. FDCs for particular months or other periods

It is always important to know when, during the year, water will be available for generation. This is required when considering the economics of schemes in those networks where tariffs, paid by utilities to independent producers, vary with the season of the year and time of day.

FDCs can be produced for particular periods of time as well as for particular years. Indeed, it is standard practice to prepare FDCs for six "winter" months and six "summer" months. This can be taken further, to obtain FDCs for individual months, if so desired. It is simply a matter of extracting the flow records for a particular month from each year of record and treating these data as the whole population. If sufficient flow records for this process do not exist, then the rainfall record can be used.

3.4.5. Water Pressure or “head”

**3.4.5.1. Evaluation of gross head**

The gross head is the vertical distance that the water falls through in giving up its potential energy (i.e. between the upper and lower water surface levels).

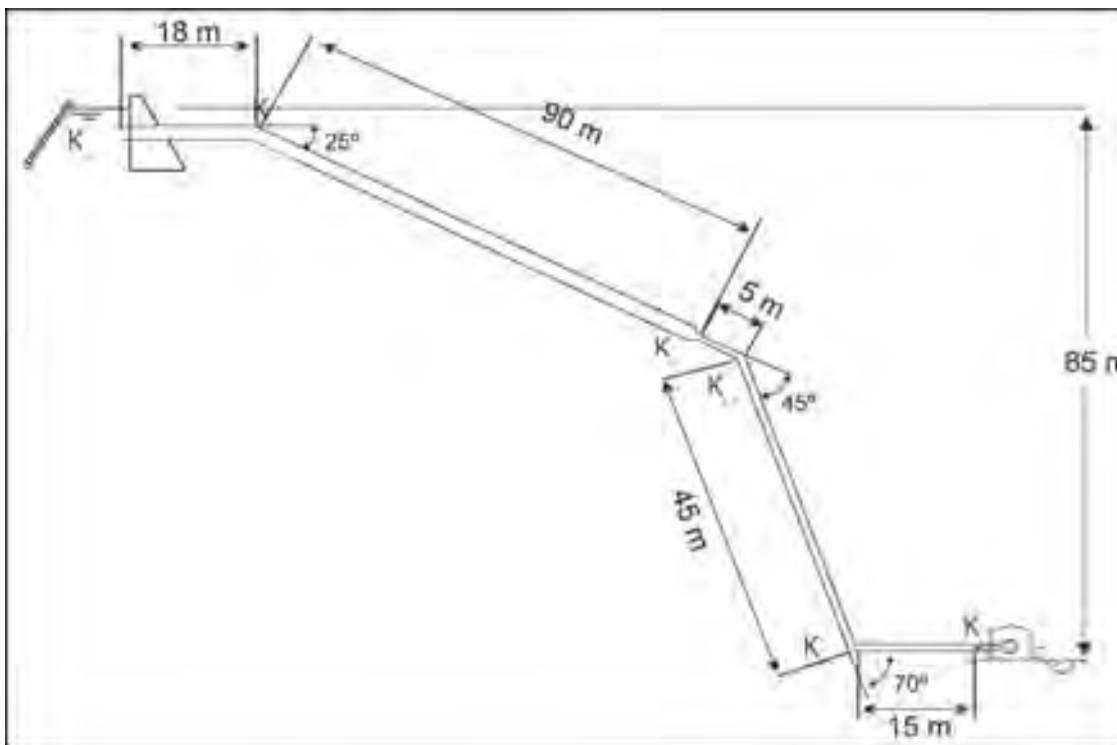
Field measurements of gross head are usually carried out using surveying techniques. The precision required in the measurement will limit the methods that can be employed.

In the past, the best way to measure gross head was by levelling with a surveyor’s level and staff, however this was a slow process. Accurate measurements were made by a tachometer or less accurately by a clinometer or Abney level. Nowadays with digital theodolites, electronic digital and laser levels and especially with the electronic total stations the job has been simplified.

The modern electronic digital levels provide an automatic display of height and distance within about 4 seconds with a height measurement accuracy of 0.4 mm, and the internal memory that can store approximately 2,400 data points. Surveying by Global Positioning Systems (GSM) is now used widely and a handheld GPS receiver is ideal for field positioning, and rough mapping.

**3.4.5.2. Estimation of net head**

Having established the gross head available, it is necessary to make allowances for the losses, from trash racks, pipe friction, bends and valves. In addition to these losses, certain types of turbines need to discharge their water to atmosphere, above the level of the tail water (the lower surface level).



**Figure 3-11 Conveyance system (example 3.1)**

The gross head minus the sum of all the losses equals the net head, which is available to drive the turbine. Example 3.1 will help to clarify the situation:

**Example 3.1**

**Figure 3.13 shows the pipe layout in a small hydropower scheme. The nominal discharge is 3 m<sup>3</sup>/s and the gross head 85 m. The penstock is 1.5 m diameter in the first length and 1.2 m in the second one. The radius of curvature of the bend is four times the diameter of the pipe. At the entrance of the intake there is a trash rack inclined 60° with the horizontal. The rack is made of stainless steel flat bars, 12 mm thick and the width between bars is 70 mm. Estimate the total head loss?**

According to experience the velocity at the entrance of the rack should be between 0.25 m/s and 1.0 m/s. The required trash rack area is estimated by the formula:-

$$S = \frac{1}{K_1} \left( \frac{t}{t+b} \right) \frac{Q}{V_0 \sin \alpha}$$

where S is the area in m<sup>2</sup>, t the bar thickness (mm), b the distance between bars (mm), Q the discharge (m<sup>3</sup>/s), V<sub>0</sub> the water velocity at the entrance and K<sub>1</sub> a coefficient which, if the trash rack has an automatic cleaner, is equal to 0.80. Assuming V<sub>0</sub> = 1 m/s, S = 5.07 m<sup>2</sup>. For practical reasons a 6 m<sup>2</sup> trash rack may be specified, corresponding to a V<sub>0</sub> = 0.85 m/s, which is acceptable. The headloss traversing the trash rack, as computed from the Kirschner equation

$$h_r = 2,4 \left( \frac{12}{70} \right)^{3/4} \frac{0,8^2}{2 \cdot 9,81} = 0,007 \text{ m}$$

The friction losses in the first penstock length are a function of the water velocity, 1.7 m/s. The entrance to the pipe has a good design and coefficient K<sub>e</sub> = 0.04 (see figure 2.11). The head loss in the first length according to Manning's equation is:

$$\frac{h_F}{L} = 0,00177; h_f = 0,19 \text{ m}$$

The headloss coefficient in the first bend is K<sub>b</sub> = 0.085 (one half of the corresponding loss of a 90° bend); in the second K<sub>b</sub> = 0.12 and in the third K<sub>b</sub> = 0.14. The taper pipe, with an angle of 30°, gives a loss in the contraction h<sub>c</sub> = 0.02 m (for a ratio of diameters 0.8 and a water velocity in the smaller pipe = 2,65 m/s)

The friction headloss in the second length is computed in the same way as the first one, and accordingly

$$\frac{h_F}{L} = 0,0169; h_f = 1,10 \text{ m}$$

The coefficient of headloss in the gate valve is K<sub>v</sub> = 0.15. Therefore the headloss due to friction is estimated to be

$$0.19 + 1,10 = 1.29 \text{ m}$$

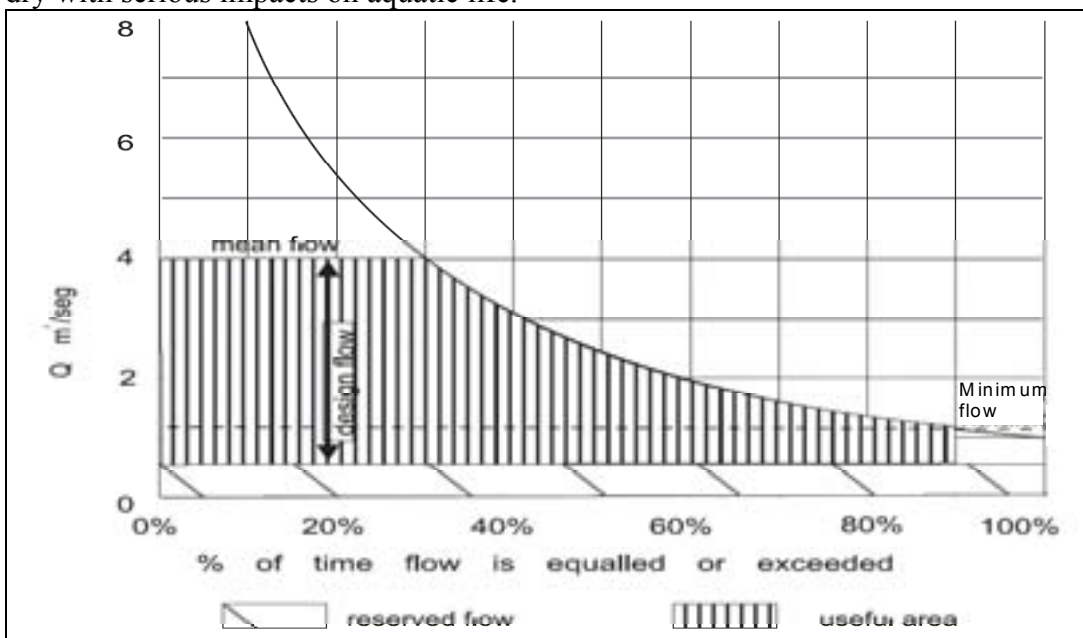
The additional headlosses will be as follows:-

• In the trash rack		0.007 m
• In the pipe entrance	0.04 x 0,147	0.059 m
• In the first bend	0.085 x 0.147	0.013 m
• In the second bend	0.12 x 0,359	0.043 m
• In the third bend	0.14 x 0,359	0.050 m
• In the confusor	0.02 x 0,359	0.007 m
• In the gate valve	0.15 x 0,359	0.054 m
	Headlosses	0,233 m

The total head loss is equal to 1,29 m friction loss plus 0,23 m in local losses, giving a net head of 83.48 m. This represents a loss of power of 1,8% which is reasonable.

**3.5. Residual, reserved or compensation flow**

Uncontrolled abstraction of water from a watercourse (e.g. passing it through a turbine) even if it is returned to the stream close to the intake, could lead to sections of the watercourse being left almost dry with serious impacts on aquatic life.



**Figure 3-12 Residual flow**

To avoid this happening, permission to divert water through a hydro turbine or a licence to abstract from a river or stream will almost always specify that a certain residual flow should remain. The residual flow is sometimes called other names, depending on the country, or authority responsible, e.g. "reserved flow", "prescribed flow" and "compensation flow" are terms commonly used.

This residual flow should be carefully evaluated since a flow that is too small would cause damage to aquatic life in the stream. On the other hand an unnecessarily large flow effects the power production and especially so in periods of low flow, thus reducing the benefits of the installation.

**3.6. Estimation of plant capacity and energy output**

The FDC provides a means of selecting the right design discharge, and by taking into account the reserved flow and the minimum technical turbine flow, an estimate of the plant capacity and the average annual energy output.

Figure 3.12 illustrates the FDC of the site it is intended to evaluate. The design flow has to be identified through an optimisation process, studying a range of different flows, which normally gives an optimum design flow significantly larger than the difference between the mean annual flow and the reserved flow. Once the design flow is defined and the net head estimated, a suitable type of turbine must be identified (refer chapter 6).

Figure 3.12 shows the useable region of the flow duration curve. Every selected turbine has a minimum technical flow (with a lower discharge the turbine either cannot operate or has a very low efficiency) and its efficiency is a function of the operating discharge.

The average annual energy production (E in kWh) is a function of:

$$E = \text{fn} (Q_{\text{median}}, H_n, \eta_{\text{turbine}}, \eta_{\text{gearbox}}, \eta_{\text{transformer}}, \gamma, h)$$

Where:

$Q_{\text{median}}$  = flow in m<sup>3</sup>/s for incremental steps on the flow duration curve

$H_n$  = specified net head

$\eta_{\text{turbine}}$  = turbine efficiency, a function of  $Q_{\text{median}}$

$\eta_{\text{generator}}$  = generator efficiency

$\eta_{\text{gearbox}}$  = gearbox efficiency

$\eta_{\text{transformer}}$  = transformer efficiency

$\gamma$  = specific weight of the water (9.81 kN/m<sup>3</sup>)

$h$  = number of hours for which the specified flow occurs.

The energy production can be calculated by dividing the useable area into vertical 5% incremental strips starting from the origin. The final strip will intersect the FDC at  $Q_{\text{min}}$  or  $Q_{\text{reserved}}$  whichever is larger. For each strip  $Q_{\text{median}}$  is calculated, the corresponding  $\eta_{\text{turbine}}$  value is defined for the corresponding efficiency curve, and the energy contribution of the strip is calculated using the equation:

$$E = W \times Q_{\text{median}} \times H \times \eta_{\text{turbine}} \times \eta_{\text{generator}} \times \eta_{\text{gearbox}} \times \eta_{\text{transformer}} \times \gamma \times h$$

Where:  $W$  = strip width = 0.05 for all strips except the last one that should be calculated

$h$  = number of hours in a year

$\gamma$  = specific weight of the water (9.81 kN/m<sup>3</sup>)

The average annual energy production is then the sum of the energy contribution for each strip. The capacity of each turbine (kW) will be given by the product of their design flow (m<sup>3</sup>/s), net head (m), turbine efficiency (%), and specific weight of the water (kNm<sup>-3</sup>).

In Chapter 6, curves of turbine efficiency against flow for the commercial turbines are shown. Table 3.2 gives the minimum technical flow for different types of turbines as a percentage of the design flow.

**Table 3-2 Minimum technical flow of turbines**



Turbine type	Q <sub>min</sub> (% of Q <sub>design</sub> )
Francis	50
Semi Kaplan	30
Kaplan	15
Pelton	10
Turgo	20
Propeller	75

3.6.1. How the head varies with the flow and its influence on the turbine capacity

Depending on the river flow and the flow admitted to the turbines, the head can vary significantly.

**The upstream water level** may vary with flow. If the intake pond is controlled by an overflow weir without any gates, the water level will rise with the flow. However, if the intake pond is controlled by gates in order to operate at a specified reservoir level, the water level may remain constant even during high flow periods. During low flow periods, the upstream water level may also be lower due to draw down of the reservoir.

**The head losses in the adduction system** varies with the square of the admitted flow, and thus for low flow seasons with low turbine flow the head loss in the adduction system can be substantially reduced.

**The downstream water level may vary with the flow.** This depends on the water body into which the water is discharged. If discharging directly into a headwater pond controlled by gates in a downstream development, the water levels may remain almost constant even for higher flows. If the water is discharged into a natural stream, the water levels again may vary considerably.

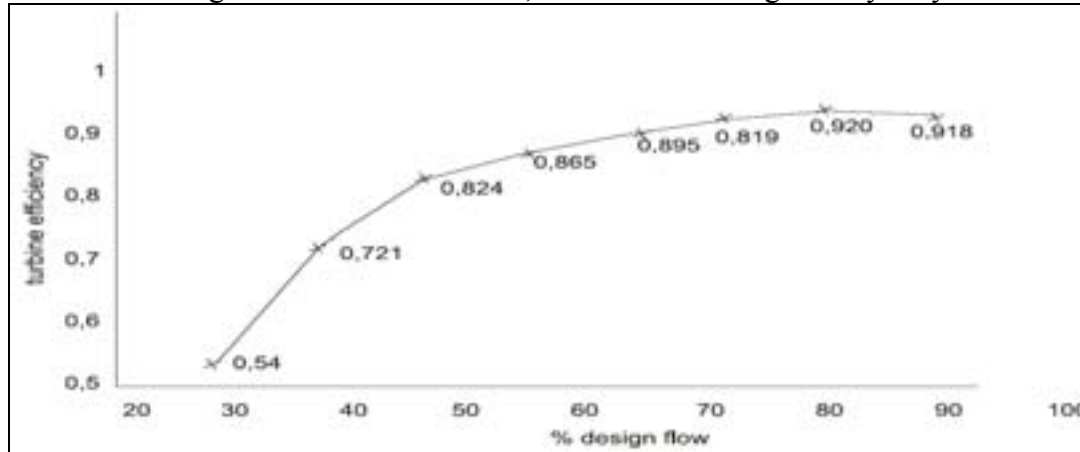


Figure 3-13 Example of turbine efficiency as a function of flow

In medium and high head schemes the head can be considered constant, because variations in the upper or lower surface levels are small compared with the head. In low head schemes, when the flow increases over the value of the rated flow of the water surface level, both in the intake and in the tailrace, may increase but at different rates, so that the head can potentially increase or decrease.

If a turbine operates with a head  $H_1 = Z_{Upstream} - Z_{Downstream}$ , other than the rated head  $H_d$ , the flow admitted by the turbine will be:- note finished at 13/0305

$$Q_1 = Q_d \cdot \sqrt{\frac{H_1}{H_d}} \tag{3.7}$$

Headwater level is normally kept at spillway crest level when all the river discharge passes through the turbines. When the river discharge exceeds maximum turbine discharge, excess flow will pass over the spillway. The reservoir level corresponding to different spillway flows can easily be calculated. In this case measuring the head on the spillway crest we have at the same time the level of the intake water surface and the river discharge (including the discharge from the turbines).

The tailrace level is more difficult to estimate. The Hydrologic Engineering Centre (HEC) of the US Army Corp of Engineers in Davis, California, has developed a computer program, HEC RAS, that can be downloaded free of charge from INTERNET (<http://www.usace.army.mil>). Although freely available and straightforward to use, the results as always depend on the quality of the input. Figure 3.14 shows an example of how the head varies with the flow in a real case and its influence on the power delivered at different river discharges.

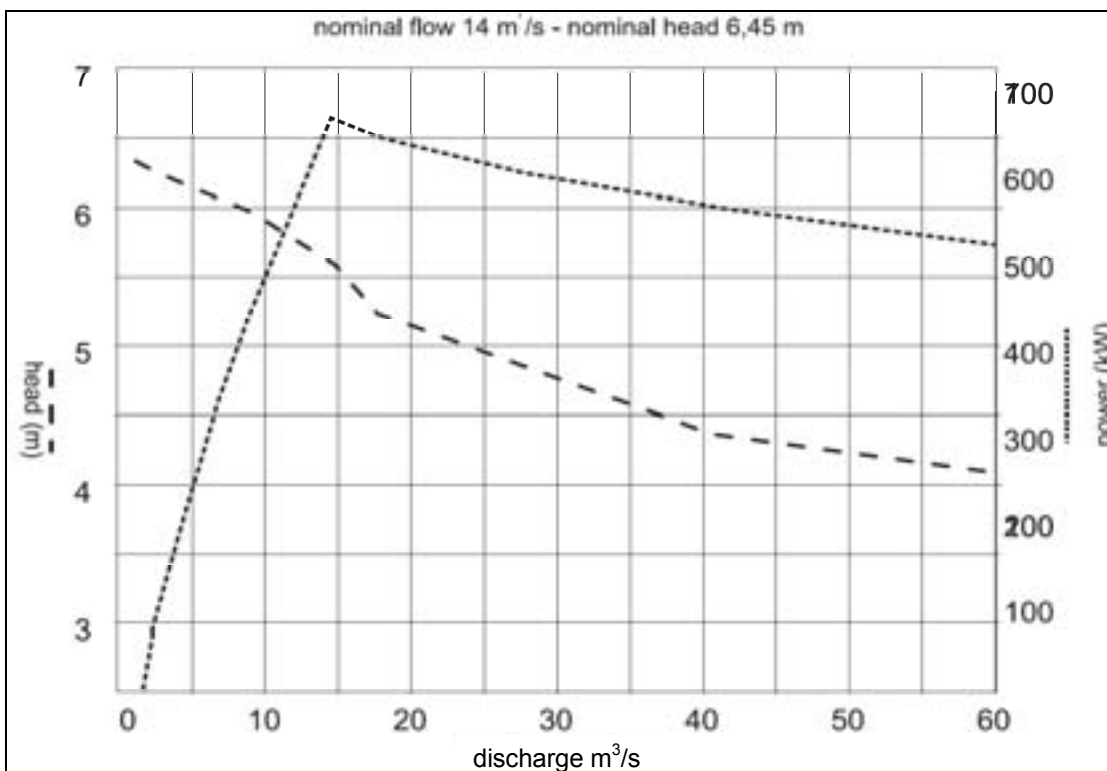


Figure 3-14 Variation of net head vs. river flow

### 3.6.2. Peaking operation

Electricity prices at peak hours can be substantially higher than in off-peak hours, hence the interest in providing an extended forebay or pound, big enough to store the water necessary to operate, at maximum during peak hours. To evaluate this volume:-

- $Q_R$  = river flow ( $m^3/s$ )
- $Q_D$  = rated flow ( $m^3/s$ )
- $Q_P$  = flow needed to operate in peak hours ( $m^3/s$ )
- $Q_{OP}$  = flow needed to operate in off-peak hours ( $m^3/s$ )
- $t_P$  = daily peak hours
- $t_{OP}$  = daily off-peak hours ( $24 - t_P$ )
- $Q_{res}$  = reserved flow ( $m^3/s$ )

$Q_{\min}$  = minimum technical flow of turbines (m<sup>3</sup>/s)  
 H = head (m)

The volume V will be given by:-

$$V_R = 3.600 \cdot t_P \cdot (Q_P - (Q_R - Q_{res}))$$

If the pound should be refilled in off-peak hours

$$t_P (Q_P - (Q_R - Q_{res})) \leq t_{OP} (Q_R - Q_{res})$$

hence :-

$$Q_P \leq t_{OP} / t_P \cdot (Q_R - Q_{res})$$

the flow available to operate in off-peak hours will be:-

$$Q_{OP} = \frac{24(Q_R - Q_{res}) - t_P Q_P}{t_{OP}} > Q_{\min}$$

### **3.7. Firm energy**

Firm energy is defined as the power that can be delivered by a specific plant during a certain period of the day with at least 90 –95% certainty. A run-of-river scheme has a low firm energy capacity. A hydropower plant with storage does, however, have considerable capacity for firm energy.

If the hydropower scheme is to be connected to an electrical network that includes several types of power and where the hydropower installations are geographically distributed, as is the case in Europe, the firm power capacity of singular plants may, not be important.

If a small hydro scheme has been developed as the single supply to an isolated area, the firm energy is extremely important. As failure to meet demand, could result in power shortages and blackouts.

### **3.8. Floods**

The stream flow is the fuel of the plant, but stream flow in the form of floods is also a potential threat to all structures built in rivers. Therefore the hydrological investigation must address not only water availability for production, but also frequency and severity of floods so as to design flood protection and control into the scheme. The design flood is not only characterized by its peak value of flow, but a hydrograph flood flows should show the distribution of the flow over time.

#### **3.8.1. Flood Control Design**

It is important to distinguish between inflow floodwater and required spillway capacity, since considerable routing effects take place in reservoirs.

For reservoirs with dams that are at risk from high floodwaters it is usual to consider two differing criteria:

1. **Maximum Inflow Design Flood** - that the facilities should be able to accommodate the floodwater, without unacceptable risk of dam failure or other serious damages to the structures. This flood is normally defined as the PMF, (Probable Maximum Flood) or similar.

2. **Normal Operation Design Flood** - that the facilities should be able to accommodate floodwater without exceeding normal conditions of operation. This flood is usually defined as a flood with a specific return period.

Whereas for medium and low hazard dams, the requirements often discard the routing effects of the reservoir, and specify that the spillway capacity shall exceed the peak flow of a flood with a specific return period, typically between 100 and 1000 years.

The requirements regarding the design flood are usually specified in national legislation or industry guidelines, and distinguish between high, medium and low hazard structures. In table 3.3 below, typical design flood requirements are given:

**Table 3-3 Typical design flood criteria**

Structure	Design Flood
High Hazard	<u>Maximum Inflow Design Flood</u> : PMF, Probable Maximum Flood or similar. Alternatively 10.000-year flood <u>Normal Operation Design Flood</u> : 1000-year flood.
Medium Hazard	100- to 1000-year flood
Low Hazard	Typically 100-year flood although in some countries no formal requirements exist.

With a 100-year flood, an annual probability of occurrence is understood to be 1/100. In other words, the Return Period is the inverse of the frequency. In the table below, the probability of occurrence during different life spans for different event frequencies is shown.

**Table 3-4 Probability of occurrence**

Life Span Frequency (Return Period)	10 years	50 years	100 years	200 years
0,01 (100)	9,6 %	39 %	63 %	87 %
0,001 (1 000)	1 %	5 %	9,5 %	18 %
0,0001 (10 000)	0,1 %	0,5 %	1%	2%

The economically optimal design flood return period for a specific dam, considering the marginal cost of additional spillway capacity and the cost of failure, is usually higher than the 100-year flood even for low hazard structures.

### 3.8.2. Statistical analysis of flood data

There are basically two ways of arriving at a design flood:

- Statistical analysis of stream flow records
- Hydrological modelling of the catchment area

Typically, statistical analysis is used for less important structures that would not cause dramatic consequences to life and society in case of failure, whereas hydrological modelling is required for important and potentially dangerous dams in case of failure.

The object of the hydrological modelling is to arrive at a Probable Maximum Flood, or similar, to be used for dam and spillway design. Frequency analysis is a statistical method to calculate the probability of an event based on a series of previous events.

The technique for estimating the return period of flows is straightforward and based on records of annual maximum flows. For the evaluation, a probability distribution that fits to the phenomenon must be chosen. Generally logPearson III is recommended for flood estimation since it allows for non-symmetrical probability distributions around the mean value, which is often the case in hydrology, however the lognormal distribution is still widely used.

The non-symmetrical distribution is expressed in a skew coefficient. LogPearson III and the calculation of the skew coefficient are very sensitive for short data series. Therefore, it is recommended to use a modified skew factor based not only on the actual data series, but also includes general experience for the specific geographical region.

In the graphical method, the annual maximum floods are arranged in order of size and then plotted on probability paper applicable for the desired distribution. Generally the ordinate represents the value and the abscissa represents the probability. The data are expected to fit, as close as possible, to a straight line. The graph can then be used for interpolation, extrapolation or comparison purposes.

In case of extrapolation, effects of errors are magnified and caution is recommended.

In the analytical method, the mean value, standard deviation as well as the skew coefficient (in case of logPearson III) of the logarithmic value of the flow record is calculated. Based on the desired frequency, a frequency factor is read from a diagram. The logarithms of floods corresponding to certain frequencies are then calculated as the mean value plus the standard deviation multiplied with the corresponding frequency factor. The logarithms are then converted to actual flow values.

Both methods are explained in more detail in standard hydrology textbooks.

As an illustrative example the 100-year flood is calculated using the analytical method for the lognormal and logPearson III probability distribution based on the following time series of annual maximum flows:

Flow (m <sup>3</sup> /s)	0	1	2	3	4	5	6	7	8	9
1970-	65	32	45	87	34	29	26	35	42	41
1980-	36	29	55	46	31	26	34	31	39	61

**The steps are as follows:**

- 1: Calculate the logarithmic value of the flow records
- 2: Calculate the mean of the logarithms
- 3: Calculate the standard deviation of the logarithms
- (3b: Calculate the skew factor for LogPearson III)
- 4: Read the frequency factor for the desired probability (f = 0,01)
- 5: Calculate the logarithm of the 100-year flow
- 6: Convert the logarithm to a flow value:

Using the LogNormal distribution the 100-year annual maximum flow is estimated at 83 m<sup>3</sup>/s, and for the Log Pearson III distribution almost 25 % higher, or 103 m<sup>3</sup>/s. Which value is the more correct? This example illustrates that even though the methods are straightforward, a good professional judgment is required as to applicability and choice of method.

### 3.8.3. Hydrological modelling of the catchment area

In order to arrive at a design flood using hydrological modelling, a design rainfall is introduced to a hydrological model comprising various components. The design rainfall is combined with other critical factors such as soil moisture content, snow melting, ground water magazine contents etc.

This task is best left to the experts.

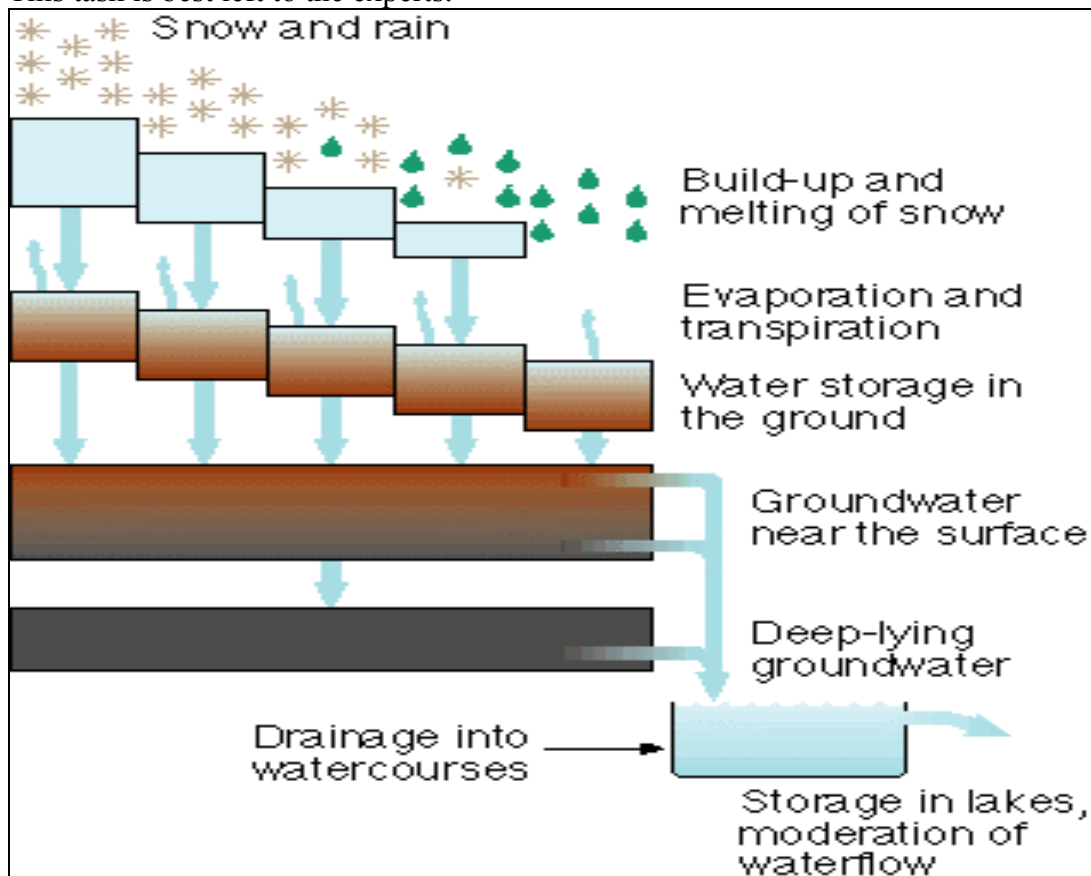


Figure 3-15 Components of hydrological model

## **Bibliography**

1. José Llamas, “Hidrología General. Principios y Aplicaciones”. Servicio Editorial de la Universidad del País Vasco, 1933.
2. ISO 1100-1: 1996 “Measurement of liquid flow in open channels. Part 1: Establishment and operation of a gauging station”.
3. ISO/DIS 110-2 “Measurement of liquid flow in open channels – Part 2: Determination of the stage-discharge relation” (revision of ISO 1100-2: 1982).
4. ISO 2537: 1988 “Liquid flow measurement in open channels – Rotating element currentmeters”.
5. ISO 955-1: 1994 “Measurement of liquid flow in open channels – Tracer dilution methods for the measurement of steady flow – Part 1: General”.
6. ISO 3846: 1989 “Liquid flow measurement in open channels by weirs and flumes – Rectangular broad-crested weirs”.
7. ISO 3847: 1977: “Liquid flow measurement in open channels by weirs and flumes – End-depth method for estimation of flow in rectangular channels with a free overfall”.
8. ISO 4359-1983 “Liquid flow measurement in open channels: Rectangular, trapezoidal and Ushaped flumes”.
9. ISO 4360: 1984 “Liquid flow measurement in open channels by weirs and flumes – Triangular profile weirs”.
10. ISO 4362: 1992 “Measurement of liquid flow in open channels – Trapezoidal profile”

---

<sup>i</sup> By Jonas Rundqvist (SERO), Bernhard Pelikan (ÖVFK), Vincent Denis (MHyLab) and Celso Penche (ESHA)

## CHAPTER 4: SITE EVALUATION METHODOLOGIES

### CONTENTS

4.	SITE EVALUATION METHODOLOGIES .....	72
4.1.	Introduction.....	72
4.2.	Cartography.....	72
4.3.	Geochemical Studies.....	73
4.3.1.	Methodologies to be used .....	73
4.3.2.	Methodologies. The study of a practical case.....	75
4.3.2.1.	The weir .....	75
4.3.2.2.	The open channel .....	76
4.3.2.3.	The channel in tunnel.....	78
4.3.2.4.	The powerhouse .....	82
4.4.	Learning from failures .....	82

### LIST OF FIGURES

Figure 4-1	Schematic representation of the site.....	74
Figure 4-2	Weir location and structures of both slopes .....	75
Figure 4-3	Geological section of the colluvial formation.....	76
Figure 4-4	Geomorphologic scheme of the channel trace .....	76
Figure 4-5	A schematic cut of the tunnel under the colluvium.....	79
Figure 4-6	Concrete lining forming the final section of the canal.....	79
Figure 4-7	A thrust fault, present in the La Rienda tunnel .....	81
Figure 4-8	results of the jet-grouting operation .....	82
Figure 4-9	Scheme of Ruahihi canal.....	83
Figure 4-10	Longitudinal scheme of La Marea plant .....	86
Figure 4-11	Plan view f La Marea plant .....	86

### LIST OF PHOTOS

Photo 4-1	General view of the right-side slope .....	77
Photo 4-2	Local instabilities generated during the excavation works .....	77
Photo 4-3	One of the existing sliding scarps before the beginning of the works .....	78
Photo 4-4	A view of the Cordiñanes colluvium, under which the tunnel runs.....	78
Photo 4-5	View of tunnelling works.....	80
Photo 4-6	View of the tunnel lining.....	80
Photo 4-7	View of the tunnel lining.....	81
Photo 4-8	The effects of failure .....	84
Photo 4-9	Ruahihi canal solution.....	85
Photo 4-10	Landslide in Marea Canal .....	87
Photo 4-11	Weir undermined by seepage .....	87
Photo 4-12	Channel destroyed by uplift pressure.....	88



## **4. SITE EVALUATION METHODOLOGIES<sup>i</sup>**

### **4.1. Introduction**

Adequate head and flow are necessary requirements for hydro generation. Consequently these parameters are important factors in site selection.

Chapter 3 outlines the available methodologies for evaluating the flow that is available for power production.

In this chapter, the methodologies needed, in order to evaluate the suitability of a site for hydropower development, are presented.

The gross head may be rapidly estimated, either by field surveying or by using a GPS (Global Positioning System) or by orthophotographic techniques. With the aid of the engineering hydraulic principles outlined in Chapter 2 the net head can be determined.

Nevertheless, the selection of the most appropriate technical solution for the site will be the result of a lengthy, iterative process, where the topography and the environmental issues for a particular site, are most important. That is why a thorough knowledge of the principles is needed to avoid dangerous failures in the operation of the plant.

Surveying technologies are undergoing a revolutionary change, and the use of the technologies mentioned above may greatly assist in scheme design and reduce its cost.

### **4.2. Cartography**

In industrialised countries, scaled maps are usually available. The E.U. territory has been or is being digitised, and cartography at scale as large as 1:5 000 is already available. On the other hand, in the developing countries, the developer will be fortunate if he can find maps at 1:25 000.

Aerial photographs of topography can be substituted for maps if they cannot be found at the required scale. However aerial photographs are unlike maps in one important respect. A map has a uniform or controlled variable scale, the latter being dependent on the choice of map projection. The aerial photograph, on the other hand, does not have a constant or uniformly changing scale. Aside from lens imperfections, which for all practical purposes can be considered negligible, two major factors are responsible for variations in the scale of a photograph:-

1. The topographical relief - land, no matter how flat, is never horizontal – and...
2. The tilt of the optical axis of the camera.

Modern cameras are able to remove distortion, resulting from their axial tilt. Furthermore aerial photographs can be viewed stereoscopically or in three dimensions. The stereoscopic effect enables the geologist to identify rock types, determine geologic structures, and detect slope instability and the engineer is able to gather data necessary for a dam, open channels and penstock construction.

Depending on the required accuracy, the digitised photographs can be geocoded (tied to a co-ordinate system and map projection) and orthorectified. Distortion from the camera lens is removed by using ground control points from maps, survey data or clients GPS vectors. This is a very cost-effective way to orthorectify aerial photographs. Resolutions of 30 cm to one metre can be expected with digital orthophotos. Both hard copy and digital orthophotos in diskettes, or CDROM can be produced.

With these maps it is possible to locate the intake, trace the open channel and penstock and locate the powerhouse, with precision enough for the feasibility studies and even for the contractors to engage in the bidding phase for construction.

With stereoscopic photographs geologic problems can often be spotted, especially those concerning slope stability that can cause dangerous situations.

### **4.3. Geochemical Studies**

Very often, the need to proceed with detailed geological studies of a site, are underestimated. In many cases with regrettable consequences - seepage under the weir, open channel slides etc.

Fortunately in the E.U. member states and in many other countries all over the world, good geological maps permit initial estimates, for the security of the dam foundations, the stability of the slopes and the permeability of the terrain. However sometimes this information, should be complemented, with fieldwork particularly, drilling and sampling.

Hydraulic structures should be founded on level foundations, with adequate side slopes and widths, not subject to stability problems. There are a good number of slope stability computer programs, ranging from a simple two-dimensional approach to the sophisticated three-dimensional full colour graphic analysis. The catalogue of failures, especially in channel design is so large that a minimum geomorphologic study of the terrain should be recommended in the first phase of the project. The problem is especially acute in high mountain schemes, where the construction may be in a weathered surface zone, affected by different geomorphologic features such as soil creep, solifluction, rotational and planar soil slides and rock falls.

The weir and its corresponding reservoir can be affected by the instability of the superficial formations that can be present within its zone of influence, but at the same time the pond itself can affect these same formations. If the weir has to be founded on unconsolidated ground the variation of water level can generate instability on the reservoir's wetted slopes.

Along the open channel many geomorphologic features can adversely affect its selected line, which, together with a steep slope of the terrain, may lead to potential instability. Colluvial formations, a product of the surface mechanical weathering of the rock masses, and solifluction processes, are very active in high mountain environments where the subsoil is seasonally or perennially wet – these are some of the features that can compromise channel stability.

Drainage treatments, bench constructions and gunnite treatments, among many others, may be recommended. At the end of the canal, the forebay acts as a mini-reservoir for the penstock. Frequently, authorities require that all the water retaining embankment sections undergo stability analysis regardless of their configuration. The layout of the penstock, usually placed on a steep slope, poses problems both for its anchoring blocks and visual impact.

Deep in the valley, frequently built on an old river terrace, the powerhouse foundation poses problems that many times only can be solved by using techniques as up today as the jet grouting (see 4.2.2.4).

#### **4.3.1. Methodologies to be used**

In geological science, there is a wide spectrum of geomorphologic techniques that can be used including the most common ones:-

- **Photogeology.** As mentioned above photogrammetry - at scales from 1:10 000 to 1:5 000 – allows the geologist to identify rock types, determine geologic structures, and detect slope instability.
- **Geomorphologic maps.** The result of photogrammetric analysis complemented with the results of the field survey must be combined on a Geomorphologic Map. This map is based on a topographic one and is drawn at a scale between 1:10 000 and 1:5 000, duly classified using simple symbols, should show all the surface formations affecting the proposed hydraulic structures.
- **Laboratory analysis.** Traditional laboratory tests such as soil grading and classification, and triaxial consolidation facilitate the surface formation classification. The results should be included in the geomorphic map.
- **Geophysical studies.** A geophysical investigation either electrical or seismic (by refraction) will contribute to a better knowledge of the superficial formation thickness, the location of the landslide sections, the internal water circulation, and the volumetric importance of potentially unstable formations.
- **Structural geological analysis.** Although not a proper geomorphologic technology can help to solve problems in the catchment area and in those cases where hydraulic conduits must be tunnels in rock massifs. The stability of the rock and seepage in the foundation of hydraulic structures are problems that can be solved by this methodology, avoiding dramatic incidents during the operation.
- **Direct investigations - Borehole drilling.** This is uncommon for small hydro scheme development. However when the dam or weir has to be founded in unconsolidated strata, a drilling programme, followed by laboratory tests on the samples extracted is essential. Some of these recommended tests are:-
  1. Permeability tests in boreholes, such as Lugeon or Low Pressure Test, to define the water circulation in the foundation.
  2. Laboratory tests to determine the compressive strength of the samples to define their characteristics.

Complementing the above tests a geophysical refraction seismic essay to define the modulus of dynamic deformation of the rock massif in depth can be recommended in the case of high dams.

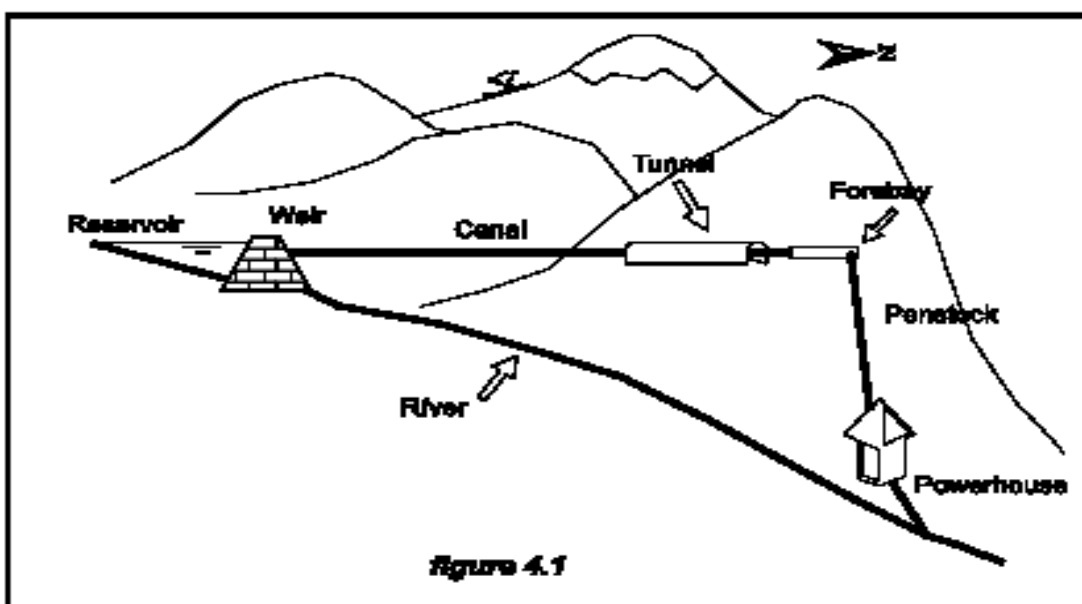


Figure 4-1 Schematic representation of the site

4.3.2. Methodologies. The study of a practical case.

A short report on the geomorphologic techniques used in the Cordiñanes scheme, a high mountain scheme located in the Central Massif of Picos de Europa (Leon, Spain) will help to demonstrate the scope of the above-mentioned studies. Figure 4.1 is a schematic representation of the site, which includes:-

- A gravity weir 11.5 meters high over foundations
- A reservoir with a storage capacity of 60 000 m<sup>3</sup>
- An open channel 2475 m long (776 m are in tunnel)
- A forebay at the end of the tunnel
- A 1.4 m diameter penstock, 650 m long with a 190 m drop
- A powerhouse

4.3.2.1. The weir

International regulations require that if there is a potential for direct shear failure or whenever sliding is possible along joints or faults, rock foundations must be analysed for stability. When necessary, additional rock excavation may be required.

Figure 4.2 shows the weir location and illustrates the entirely different structures of both slopes, the left one, steeper, follows the nearly vertically bedded slate formation; the right one less steep is associated to a colluvial formation.

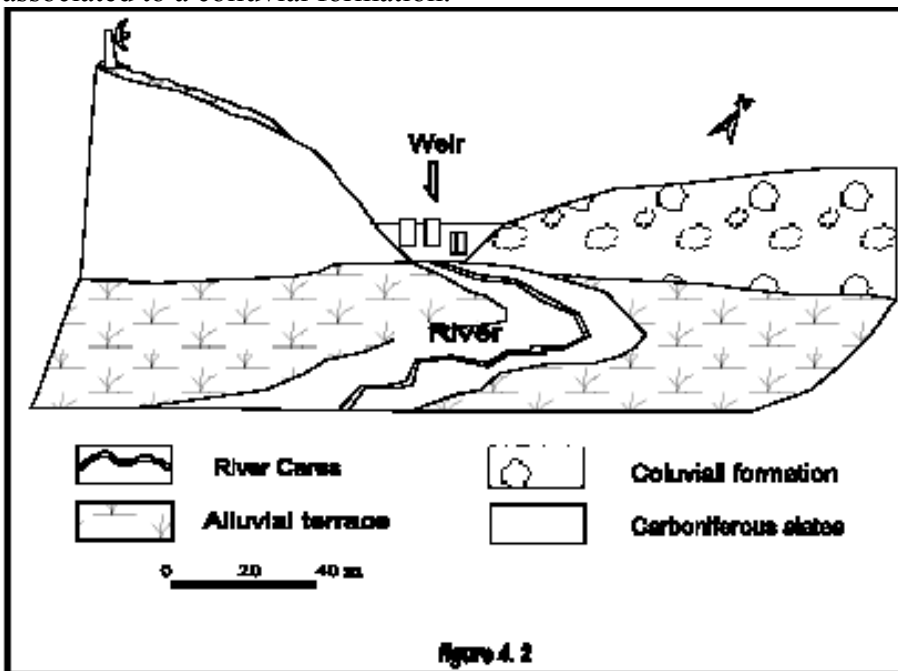


Figure 4-2 Weir location and structures of both slopes

Figure 4.3 shows the geological complexity of the colluvial formation. The borehole drilling B-1 illustrates the existence of an alluvial terrace under the colluvial formation. Each formation behaves in a different way to the requirements of the weir foundation.

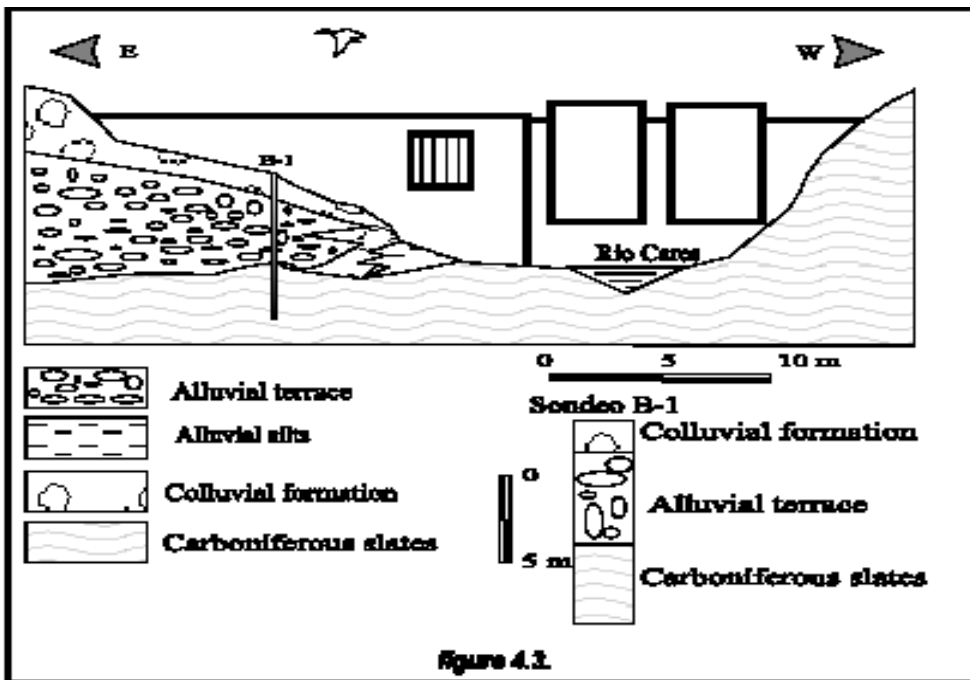


Figure 4.3

Figure 4-3 Geological section of the colluvial formation

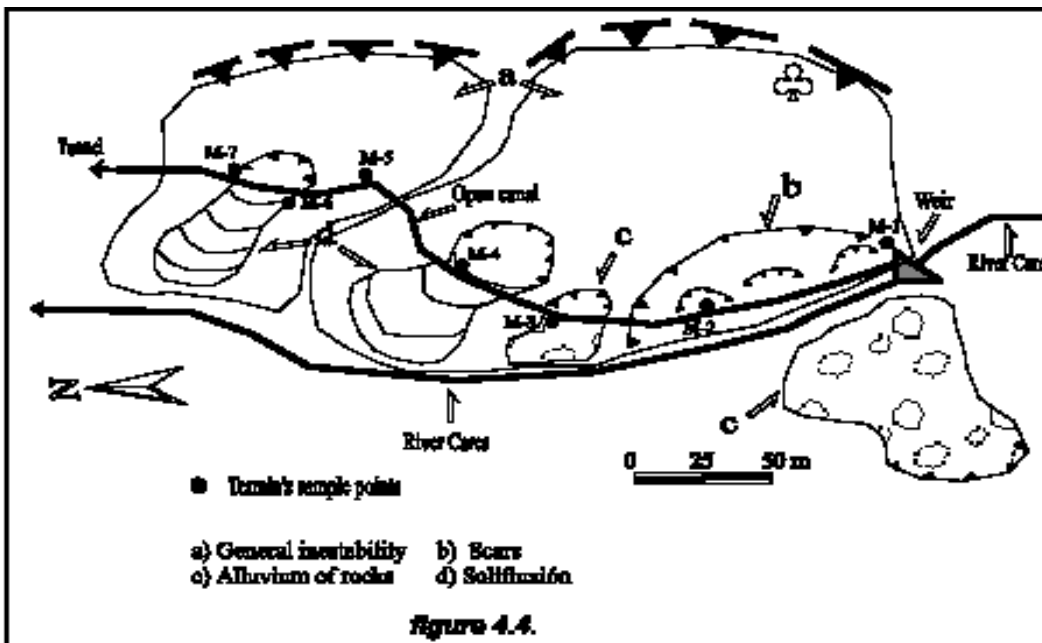


Figure 4.4

Figure 4-4 Geomorphologic scheme of the channel trace

#### 4.3.2.2. The open channel

Figure 4.4 shows a geomorphologic scheme of the channel trace. Two large independent unstable zones (b and c) can be seen in the right side of the river. Photographs 4.1 and 4.2 show a general view of the right-side slope and the local instabilities generated during the excavation works, just as a detail of one of these instabilities. Photograph 4.3 shows one of the existing sliding scarps before the beginning of the works.



**Photo 4-1 General view of the right-side slope**



**Photo 4-2 Local instabilities generated during the excavation works**

The foundation of the channel should meet two requirements:-

- Must be stable. Channels are rigid structures and do not permit deformations.
- Should be permeable. Channels do not support thrusts or uplift pressures.

The geologic studies should aim to avoid settlements in the channel and to provide adequate drainage to hinder the thrust and uplift stresses. The study should conclude with a recommendation to guarantee the stability and suppress the uplift pressures



**Photo 4-3 One of the existing sliding scarps before the beginning of the works**



**Photo 4-4 A view of the Cordiñanes colluvium, under which the tunnel runs**

#### **4.3.2.3. The channel in tunnel**

The tunnel construction must comply with the following requirements:-

The excavation will be conditioned by the geologic formations that must traverse, either a rock massif or a superficial formation.

The tunnel, being a hydraulic channel should be stable and watertight. Consequently the geologic formations that exist in the massif to be traversed must be known in detail.

Photograph 4.4 shows a view of the Cordiñanes colluvium, under which the tunnel runs. Figure 4.5 shows a schematic cut of the tunnel under the colluvium and figure 4.6 illustrates the concrete lining forming the final section of the canal.

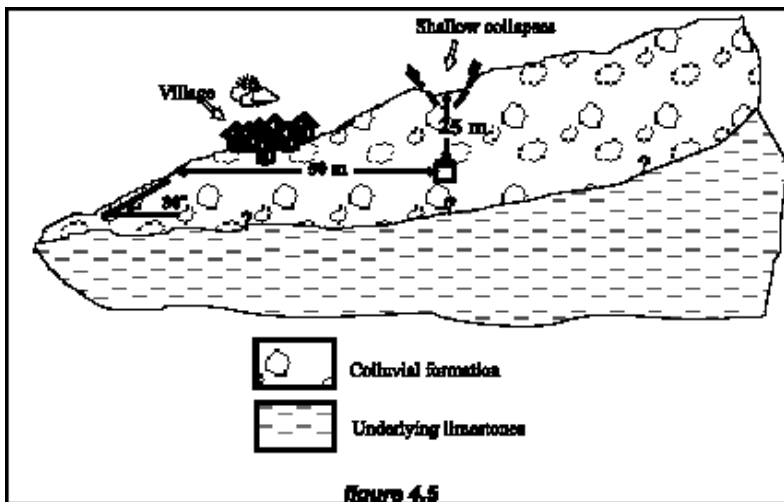


Figure 4-5 A schematic cut of the tunnel under the colluvium

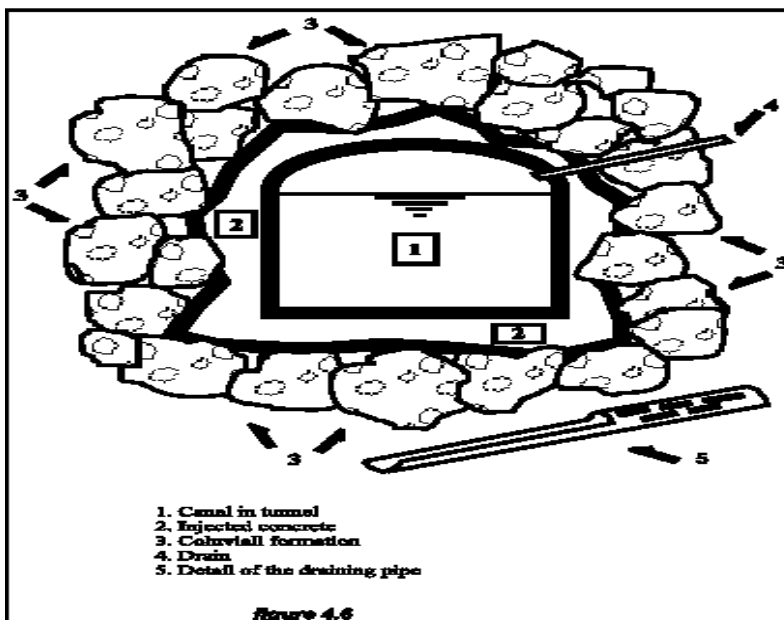


Figure 4-6 Concrete lining forming the final section of the canal

The excavation works were extremely difficult due to the large variety and heterogeneity of the blocks, which varied in size from simple stones to blocks of several cubic meters. The use of large explosive charges was not permitted here. The use of tunnelling machines was not feasible. The excavation had to proceed metre by metre, using small explosive charges to reduce the size of the blocks, which could not be handled (Photograph 4.5).

The concrete lining was also difficult. Zone 2 in figure 4.6 was filled by injecting grout. In fact this injection not only filled the empty space but also enclosed the supporting structure and reinforced the loose terrain around the tunnel. This terrain is very permeable so to avoid lateral pressures or uplift pressures a draining system was put in place.

The construction of tunnels through rocky massifs should take into account two important geologic characteristics:-



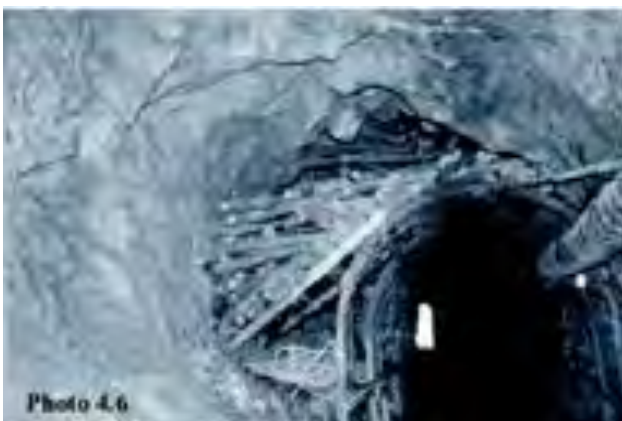
- The lithologic variation, along its trace can decisively influence the construction method to be used.
- The structural stability, of the massif along the trace. Even if the massif is lithologically coherent the distribution of the potential discontinuities in stratification planes, joints, fissures - will be far from homogeneous. Once again the knowledge of all those discontinuities must be based on a detailed structural geological study.

As well as the relatively small discontinuities referred above, the designer should also deal with the large tectonic discontinuities -large bending, faults, invert faults- that not only affect the work itself but also the future operation of the canal.

Figure 4.7 shows a thrust fault, present in the La Rienda tunnel, second part of the tunnel of Cordiñanes close to the forebay built right at the end of the tunnel. Due to the strains and deformations supported in the past by this mass of rocks, the rocks originally found were completely altered. The response to this excavation was of course very different from the response of the rest of the massif. Only by knowing the presence of this fault beforehand could the tunnel be excavated without unexpected incidents. As photographs 4.6 and 4.7 illustrate, the supporting structure during the tunnel construction was very different in this area to the one used in the rest of the work.



**Photo 4-5 View of tunnelling works**



**Photo 4-6 View of the tunnel lining**



Photo 4-7 View of the tunnel lining

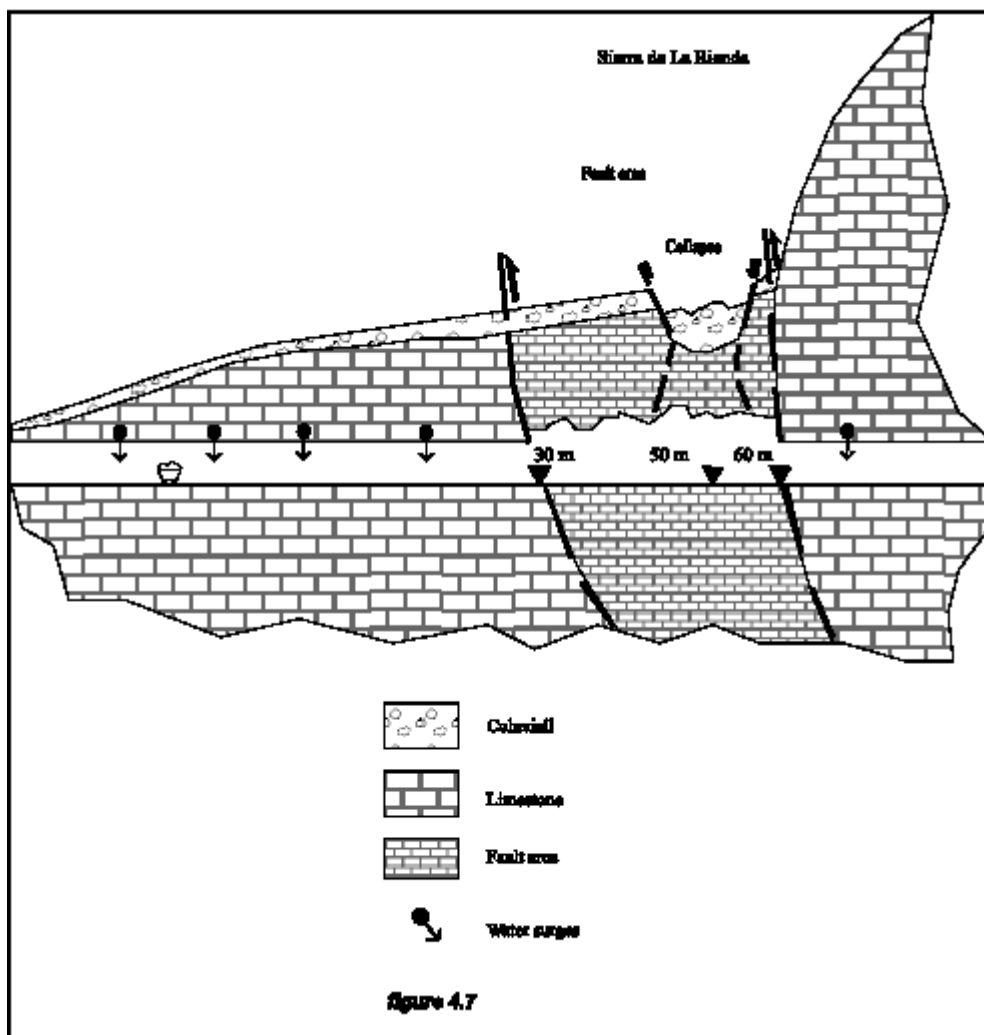


Figure 4-7 A thrust fault, present in the La Rienda tunnel

#### 4.3.2.4. The powerhouse

If the powerhouse is founded on rock, the excavation work will remove the superficial weathered layer, leaving a sound rock foundation. If the powerhouse is to be located on fluvial terraces near the riverbanks that do not offer a good foundation then the ground must be reinforced.

The traditional cement grouting presents some difficulties and in many cases its results are not satisfactory when the terrain is as heterogeneous and permeable as exists in fluvial terraces. A new injection technique, jet grouting, can guarantee the terrain consolidation, replacing alluvial sediments by an injected curtain. The technique, widely used by the DOE (Department of Energy of the U.S) to cut the seepage in the underground storage reservoir for toxic wastes, is however very expensive at present. Figure 4.8 illustrates the results of the jet-grouting operation that was performed to reinforce the terrain supporting the powerhouse.

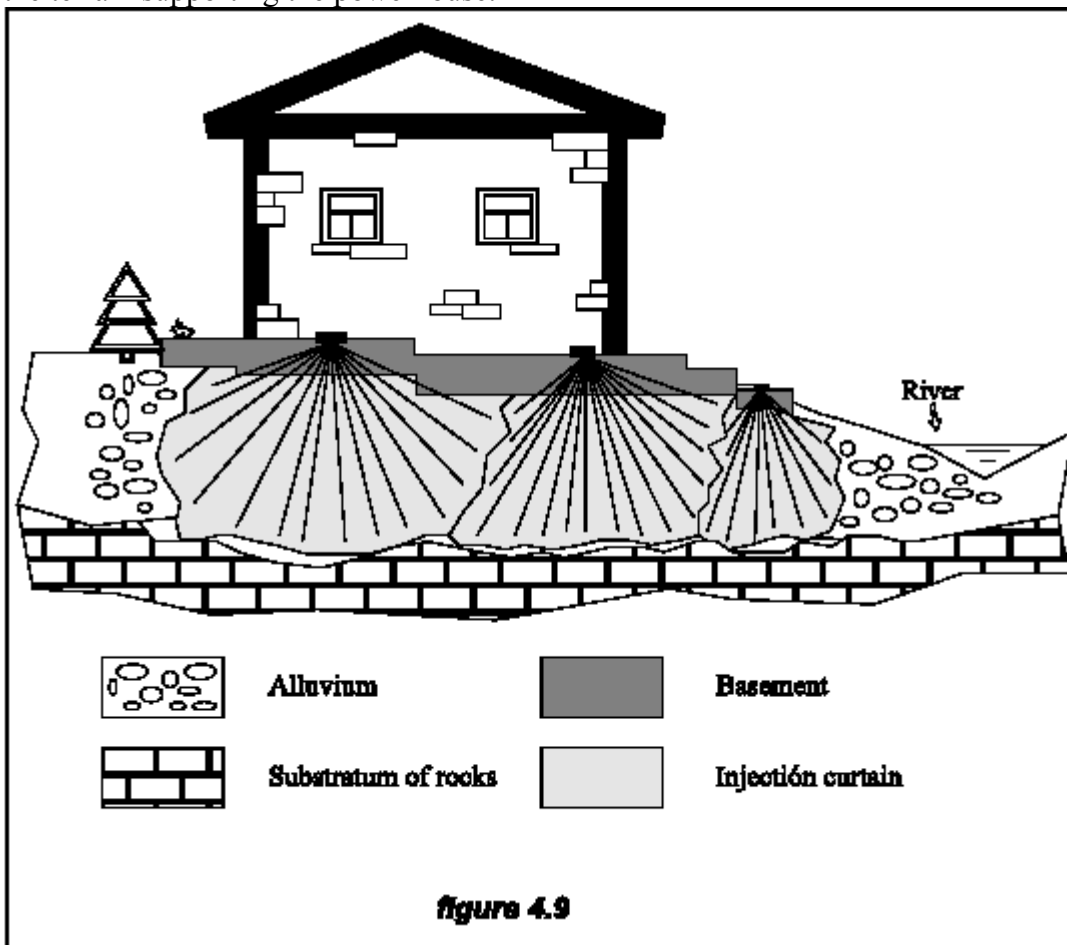


Figure 4-8 results of the jet-grouting operation

#### 4.4. Learning from failures

Two well-known experts, Bryan Leyland of Australia and Freddy Isambert from France, presented at the HIDROENERGIA95 Conference two independent papers dealing with the topic “**Lessons from failures**”.

Mr Leyland quoting Sir Winston Churchill (the famous UK Prime Minister) – “**he who ignores history is doomed to repeat it**” - claims that if one does not want to repeat the mistakes of others, the reasons for their failures must be studied and understood. According to Mr Isambert “case studies have

shown that a number of small hydro plants have failed because they were poorly designed, built or operated”.

The authors presented, with the aid of graphics and photographs, several examples of schemes that failed in the commissioning of the plant or later in the operation, and produces considerable loss of money and dramatic delays.

Professor Mosony wrote in ESHA Info no. 15, “a fair and open discussion about failures is indispensable in order to learn from failures and consequently to avoid their repetition”. Quoting Marcus Tullius Ciceron (106-43 BC) “Every human being can make a mistake, but only the idiot persists in repeating his mistake”. From the accounts of failures reported at HIDROENERGIA, together with more than 50 others described in the ASCE publication “Lessons Learned from the Design, Construction and Operation of Hydroelectric Facilities”, of which 28 of them concern schemes of less than 10 MW capacity, examples have been selected for discussion below. They demonstrate the importance of studying in depth, the stability of canals and the effects of uplift pressure on hydraulic structures.

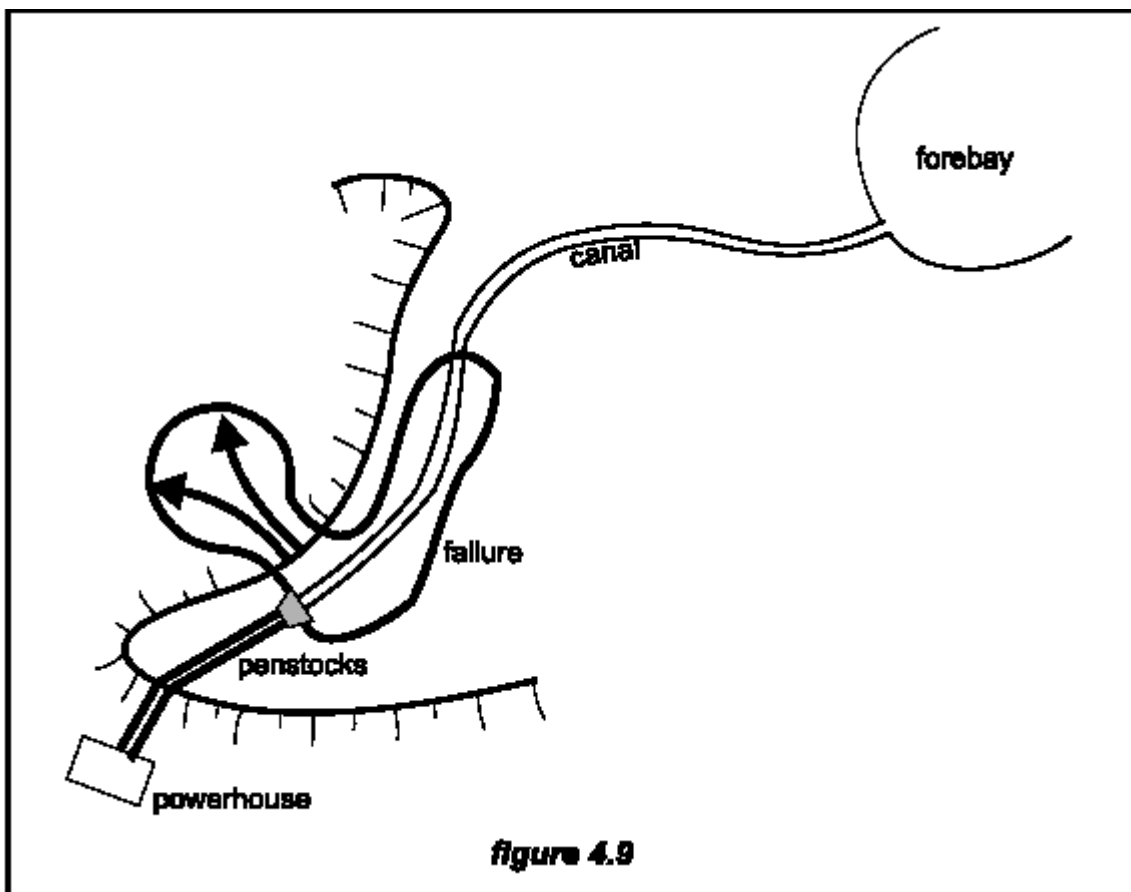


Figure 4-9 Scheme of Ruahihi canal

**Ruahihi canal failure (New Zealand)**

As shown in figure 4.9 the scheme had a 2000m canal laid along a side slope, leading to 750 m of concrete and steel penstocks. The canal was excavated in soft ignimbrite (debris from a volcanic explosion) and lined with a type of volcanic clay.

The brown ash dried and cracked during construction but due to its unusual characteristics, the cracks did not seal when the canal was filled. So water leaked into the ignimbrite below. When these leaks appeared perforated pipes were driven in to drain the bottom of the slope. This hid the problem and also made it worse because the leaking water caused caverns to form in the fill.



**Photo 4-8 The effects of failure**

On the day after the scheme was officially opened, a large section of the canal suddenly collapsed. Photograph 4.8 illustrates the magnitude of the catastrophe. Many options were examined and finally it was decided that the only viable option was to replace the failed section of canal with 1100m of pipes.

This increased the length of the penstocks from 750 m to 1850 m and required that water hammer pressures had to be reduced, because the original concrete pipes could only withstand a very limited overpressure. It was necessary to modify the relief valves and the inlet valves so that there would only be a 3% pressure rise under the worst conditions. A surge chamber was not an option because the ground could not take the extra weight. Fortunately the turbine manufacturer was very cooperative and had faith in the ability of his relief valves to limit the pressure rise to 3%, which they did. The refurbishment was completed ahead of time and under budget.

The lessons learned were:

- The characteristics of volcanic materials are highly variable and often undesirable;
- When a canal leaks, be sure the problem is fully understood before repairs commence;
- When the alternative is to abandon a failed scheme, consider the seemingly impossible there may not be a lot to lose!



**Photo 4-9 Ruahihi canal solution**

#### **La Marea canal failure (Spain)**

The La Marea scheme has a spiral Francis turbine of 1 100kW installed capacity a discharge of 1.3m<sup>3</sup>/s and a 100m head. As shown in figure 4.11 the scheme includes a small weir for the water intake, provided with a fish ladder. From the intake a rectangular canal built in reinforced concrete (3 x 2m section) is followed by another 600m long canal in tunnel. At the outlet of the tunnel a reservoir was built to store water for peak operation. The reservoir was built by compressing a mix of sand and clay, and unfortunately proved to be insufficiently watertight. From the reservoir another canal, built with prefabricated sections of concrete with thin steel plates between, brings the water to the forebay, located 100m above the powerhouse.

The canal lies on a steep slope on strongly weathered sandstone. Heavy rain was pouring over the canal both during its construction and during its commissioning. Immediately after opening the intake gate, the reservoir was filled and the water began to seep into the terrain. The wetted sandstone could not resist the shear stresses and a landslide broke the reservoir embankment (photograph 4.9), and large masses of material reached the river, and through the river, to the coast.

The reservoir was replaced by a construction in reinforced concrete, which up to the present day has served no useful purpose. Later on, the second section of the canal and the prefabricated reach, started to leak. The terrain became saturated and, unable to resist the shear stresses, failed in a rotational slide. About 200m of canal were replaced by a low-pressure welded steel pipe that up to now has been performing adequately. The pipe runs under a storage pond, waterproofed by a thermo-welded plastic sheet, and ends in the forebay.

The lessons learned were:-

- Weathered sandstone gives poor performance when resisting landslide, especially on slopes with an angle over 35° to the horizontal.

- Hydraulic canals should be built to guarantee their watertightness; alternatively a drainage system should be devised so the leakage does affect the terrain.
- The replacement of an open canal by a low pressure pipe on a steep slope may be a better option, because it will be watertight and it will require only a few anchorage points

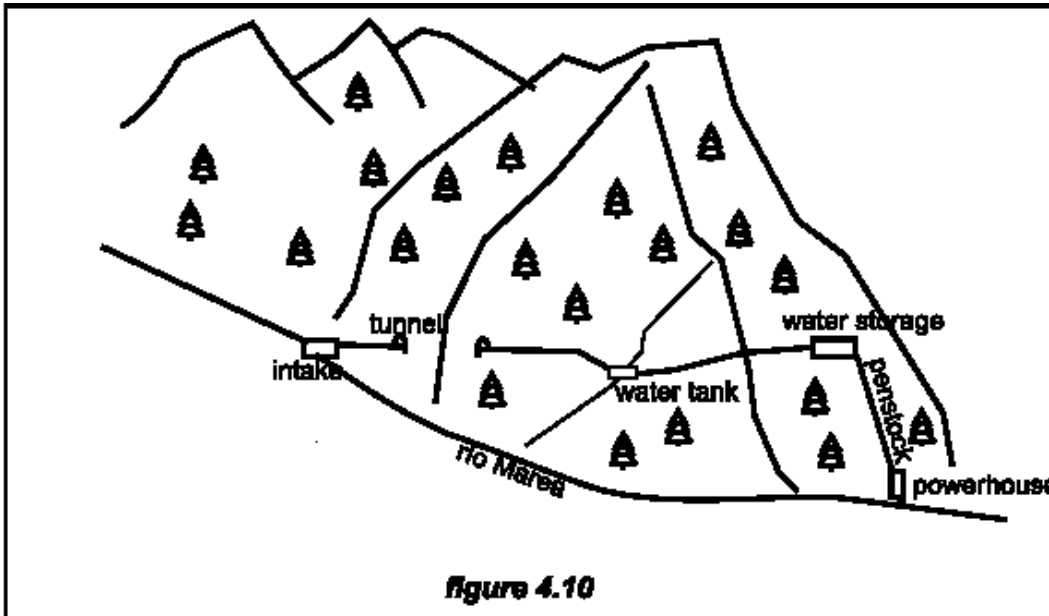


figure 4.10

Figure 4-10 Longitudinal scheme of La Marea plant

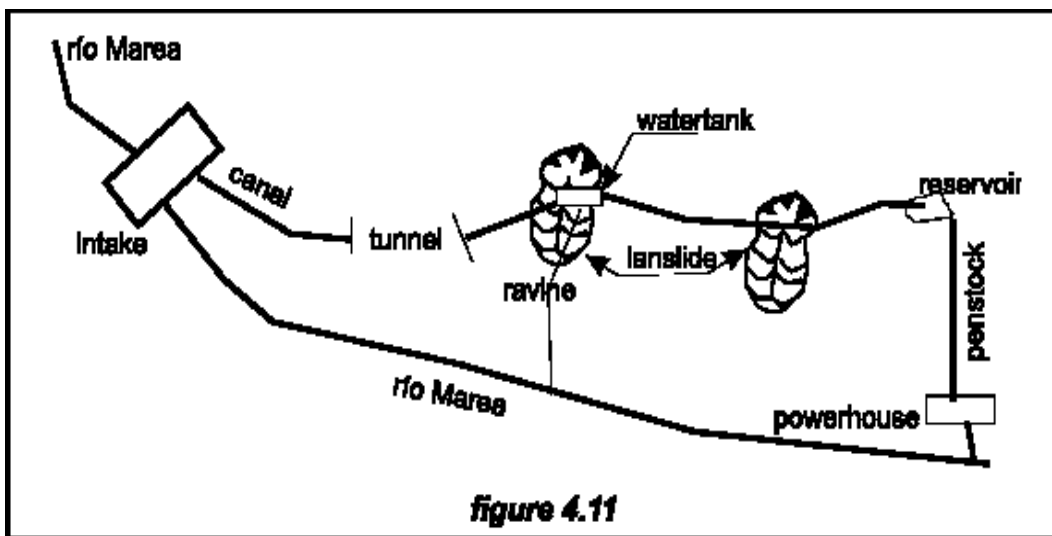


figure 4.11

Figure 4-11 Landslide in the Marea Canal

**Seepage under a weir (France)**

This case concerns a small weir, which is the furthest structure upstream of a 600kW project comprising of a buried culvert, a penstock and a powerhouse. The operating personnel had noticed minor leakage at the downstream toe of the dam. The small reservoir was emptied, and a trench was excavated so that the contact between the structure and the foundation could be examined. It was then revealed that a conduit had formed between the upstream and the downstream faces of the weir (photo 4.11), which was actually founded on permeable deposits without a cut-off trench.

The weir in this condition would have eventually failed by undermining the foundation. The key issues to learn from this case were the lack of a geomorphologic survey and inadequate supervision of the design and construction of the weir.



**Photo 4-10 Landslide in Marea Canal**



**Photo 4-11 Weir undermined by seepage**

#### **The hydraulic canal in a low-head 2MW scheme**

The hydraulic canal, 5m wide and 500m long ran along side a river. The river was known to experience frequent flash floods. On one particular day, a flood occurred which was later calculated to be a 100 year event. When the flood occurred, the turbines were stopped and all the gates closed. The headrace channel had been almost emptied by leakage, and the channel was destroyed by uplift pressure (photo 4.12). In this case the key technical issues were hydraulics, structural stability and design.





**Photo 4-12 Channel destroyed by uplift pressure**

There are other cases that could be described to show the effects of poor judgement during either the design or the construction phase. Such case studies show the number and diversity of parameters that can cause failures. It is also unfortunately evident that design, construction and site supervision are often carried out by companies, which may offer lower costs, but have little experience of hydraulic works.

---

<sup>i</sup> By Luigi Papetti (Studio Frosio), Jonas Rundqvist (SERO) and Celso Penche (ESHA)

## CHAPTER 5: HYDRAULIC STRUCTURES

### CONTENTS

5	HYDRAULIC STRUCTURES .....	93
5.1	Introduction.....	93
5.2	Dams .....	93
5.2.1	Embankment Dams .....	95
5.2.2	Concrete Dams.....	95
5.2.3	Other Dam types .....	97
5.2.4	Loads and stability for concrete dams.....	98
5.2.5	Dam Safety.....	99
5.3	Weirs and spillways .....	100
5.3.1	Weirs.....	101
5.3.2	Gated Spillways .....	103
5.3.3	Other spillways .....	104
5.4	Energy dissipating structures .....	109
5.5	Intake structures .....	109
5.5.1	General.....	109
5.5.2	Intake types .....	110
5.5.3	Head losses.....	114
5.5.4	Trashracks .....	115
5.5.5	Vorticity .....	119
5.6	Sediment traps.....	120
5.6.1	General.....	120
5.6.2	Efficiency of a sediment trap .....	121
5.6.3	Design .....	121
5.7	Gates and valves.....	122
5.8	Open channels.....	126
5.8.1	Design and dimensioning.....	126
5.8.2	Excavation and stability.....	130
5.9	Penstocks.....	134
5.10	Tailraces.....	149
	Bibliography.....	150

### LIST OF FIGURES

Figure 5.1:	A zoned embankment dam with moraine core.....	95
Figure 5.2:	Typical geometry for arch and cupola dams (single curvature arch dam to the left).....	97
Figure 5.3:	Masonry dam with vertical concrete upstream wall.....	98
Figure 5.4:	Typical timber dams .....	98
Figure 5.5:	Loads on concrete dams .....	99
Figure 5.6:	Fixed and mobile spillway structures .....	101
Figure 5.7:	Discharge characteristics for weirs.....	102
Figure 5.8:	Weir configurations .....	103
Figure 5.9:	Discharge characteristics for gated spillways.....	104
Figure 5.10:	Flashboards, articulated & embedded .....	105
Figure 5.11:	Inflatable weir.....	106

Figure 5.12: Schematic layout of siphon spillway.....	108
Figure 5.13: Schematic view of morning glory (shaft) spillway .....	108
Figure 5.14: Labyrinth weir .....	109
Figure 5.15: Secondary currents in river bends .....	111
Figure 5.16: Typical layout of lateral intake.....	112
Figure 5.17: Secondary current along the outer bend of a curved river.....	113
Figure 5.18: “Tyrolean” intake .....	114
Figure 5.19: French drop intake: a canal built in the streambed and covered by a trashrack.....	115
Figure 5.20: Trash boom layout.....	116
Figure 5.21: Formula for computing head losses.....	117
Figure 5.22: Oleo-Hydraulic cylinders .....	118
Figure 5.23: Minimum degree of submergence .....	119
Figure 5.24: Sediment traps .....	121
Figure 5.25: Wedge-shaped stopper.....	123
Figure 5.26: Butterfly valves .....	124
Figure 5.27: Globe and rotary valves.....	124
Figure 5.28: Channel design .....	131
Figure 5.29: Rectangular reinforced canal.....	131
Figure 5.30: Materials used for protection.....	132
Figure 5.31: Penstock.....	134
Figure 5.32: Penstock with concrete anchor blocks and expansion joints.....	136
Figure 5.33: Manufactured steel pipe .....	137
Figure 5.34: Energy loss .....	139
Figure 5.35: Friction and turbulence head losses.....	141
Figure 5.36: Surge tower.....	147
Figure 5.37: Surge height versus time .....	147

**LIST OF TABLES**

Table 5.1: Intake characteristics.....	111
Table 5.2: Hydraulic parameters for common canal cross-sections .....	127
Table 5.3: Optimum profile for different channel sections.....	128
Table 5.4: Different material’s characteristics.....	137

**LIST OF PHOTOS**

Photo 5.1: Examples of gravity (RCC) and buttress dams .....	96
Photo 5.2: Example of an arch dam .....	97
Photo 5.3: Failure of a small dam, the breach and the flooding downstream.....	100
Photo 5. 4. Ogee weir.....	103
Photo 5.5: Articulated flashboard .....	105
Photo 5.6: Flashboard controlled by inflatable rubber bladder.....	106
Photo 5.7: Hydroplus fusegates .....	107
Photo 5.8: Drop intake .....	113
Photo 5.9: Prefabricated booms .....	116
Photo 5.10: Telescopic hydraulic cylinders .....	118
Photo 5.11: wheel-and-axle mechanism .....	123
Photo 5.12: Hydraulic Cylinder .....	124
Photo 5.13: Large butterfly valve .....	125

---

Photo 5.14: Butterfly valve hydraulically operated .....	125
Photo 5.15: Tainter gate (left) and housing of its sector on a concrete pier .....	126
Photo 5.15: Canal in the Cordinañes.....	132
Photo 5.16: Lateral spillway .....	133
Photo 5.17:Uplift.....	133
Photo 5.18: Flume .....	133
Photo 5.19: Water jet .....	148

## 5 HYDRAULIC STRUCTURES<sup>1</sup>

### 5.1 Introduction

A hydropower development includes a number of structures, the design of which will be dependant upon the type of scheme, local conditions, access to construction material and also local building traditions in the country or region. The following structures are common in a hydro scheme:

- Diversion structure
  - Dam
  - Spillway
  - Energy dissipation arrangement
  - Fish pass
  - Residual flow arrangements
- Water conveyance system
  - Intake
  - Canals
  - Tunnels
  - Penstocks
  - Power house

Design aspects and common solutions for these structures are presented below.

### 5.2 Dams

Dams and weirs are primarily intended to divert the river flow into the water conveyance system leading to the powerhouse. Dams also produce additional head and provide storage capacity. The choice of dam type depends largely on local topographical and geotechnical conditions. For instance if sound rock is not available within reasonable excavation depth, rigid structures such, as concrete dams are difficult. Conversely, for narrow valleys, it can be difficult to find space for separate spillways, and concrete dams can be the natural choice with their inherent possibilities to integrate spillways etc in the dam body.

In the Nordic countries the ice age has left us with wide and open valleys and moraine material in abundance. Not surprisingly the vast majority of dams are embankment dams with a central core of moraine. South of the Alps natural clays suitable for dam core are not in abundance and the topography in many locations favour concrete dams.

According to the ICOLD (International Committee of Large Dams), a dam is considered "small" when its height, measured from its foundation level to the crest, does not exceed 15 m, the crest length is less than 500 m and the stored water is less than 1 million cubic meters. These parameters

can be important, because of the complicated administrative procedures often associated with the construction of large dams.

World wide, embankment dams are the more common partly due to the following characteristics, which they possess:

- Can be adapted to a wide range of foundation conditions.
- Construction uses natural materials, which can often be found locally, limiting needs for long transportation.
- The construction process can be continuous and highly mechanized.
- The design is extremely flexible in accommodating different fill materials.

Disadvantages with embankment dams are that they are sensitive to overtopping and leakage, and erosion in the dam body and its foundation. There is a higher mortality rate among embankment dams as compared to concrete dams.

Concrete dams on the other hand have drawbacks that correspond to the pros of the embankment dams:

- Require certain conditions with respect to the foundations.
- Require processing of natural materials for aggregate at the site, hauling of large quantities of cement and has a labour intensive and discontinuous construction process, leading to large unit costs.

On the other hand concrete dams have several advantages:

- They are suitable for most ranges of topography that is for wide and narrow valleys, provided that foundation conditions are right.
- They are not very sensitive to overtopping.
- A spillway can be placed at the crest, and if required over the entire length of the dam.
- Chambers or galleries for drainage, tubing and ancillary works can readily be housed within the dam body.
- Powerhouses can be placed right at the toe of the dam.

The development of the Concrete Faced Rockfill Dam (CFRD) neutralizes many of the drawbacks with core-type embankments. In particular, sensitivity to leakage and erosion is reduced, and dependence of good core material is removed.

The development of the Roller Compacted Concrete Dams (RCC-dams) introduces a continuous, highly mechanised construction process and low unit costs.

New large dams are almost always CFRD and RCC designs.

5.2.1 Embankment Dams

**Homogeneous dams:** These dams are used for low embankments (<4m) and often as secondary dams. For dam safety reasons, some type of drainage is almost always provided.

**Zoned embankment dams:** These are used for dam heights from 4m and up. Constructions are extremely sensitive to the engineering design and construction, and it is therefore vital to engage highly skilled consultants and contractors require experienced site-supervision engineers. Critical components of these dams are the core, the transition zones (filters) surrounding the core and drainage capacity of the dam toe (see figure 5.1).

**Embankments dams with membrane:** The membranes can be of different types and be located either at the upstream front of the embankment or vertically in the centre of the embankment. Membranes can be made from concrete (as in the CFRD), asphalt (Norwegian type) or in the form of a geomembrane on the upstream slope.

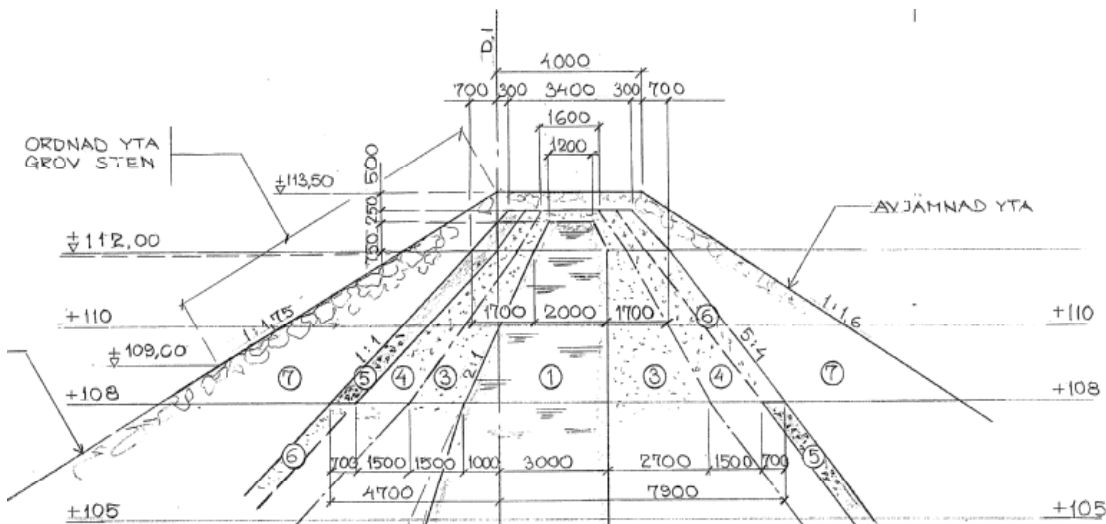


Figure 5.1: A zoned embankment dam with moraine core

Embankment dams are often categorised according to the main fill material, for example, rock-fill dams, or earth-fill dams.

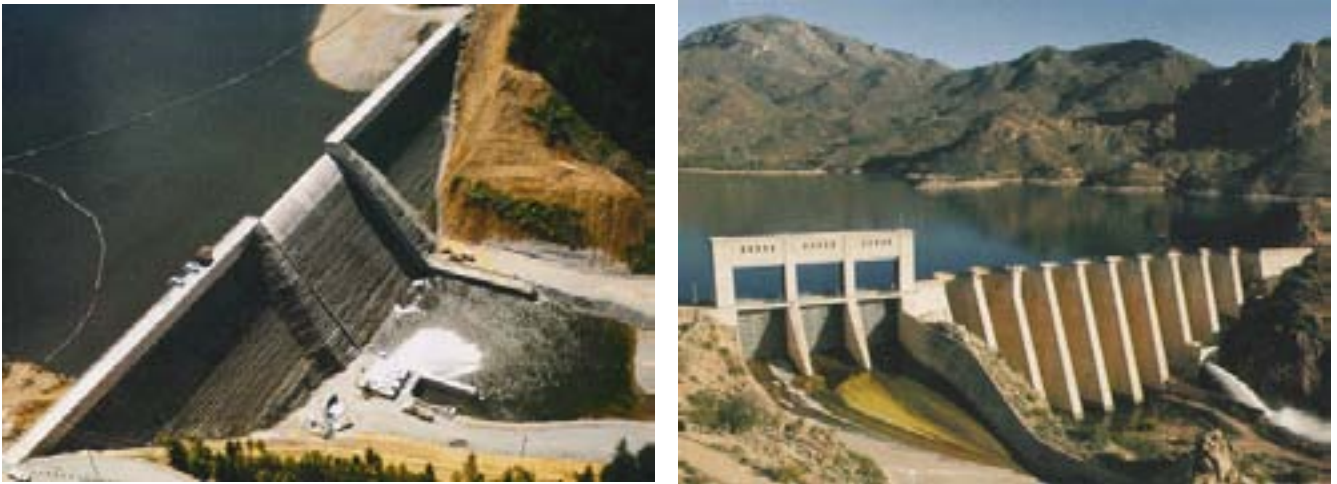
5.2.2 Concrete Dams

Generally, concrete dams are categorized according to how they function statically, and fall into one of the following groups.

**Gravity dams:** These are dependent on their own mass for stability. Their cross-section is basically triangular in order to provide adequate stability and stress distribution across the foundation plane. The upper part is normally rectangular in order to provide adequate crest width for installation and transportation.

Design issues include stability analysis (sliding and overturning), stress control, temperature control during construction to avoid cracking, control of uplift pressures under the dam, etc. In photo 5.1 a gravity dam constructed of RCC (left photo) is shown. Note the characteristic stepped downstream slope.

**Buttress dams:** These dams consist of a continuous upstream face that is supported by buttresses at regular intervals. The upstream face is normally divided into vertical sections by dilatation joints, each section being supported by a buttress. Cross-sections are similar to those of gravitation dams. In colder climates, the upstream face can be susceptible to freezing of the water contained in the concrete, damaging the concrete. For this reason buttress dams in such locations are often covered along the downstream contour of the buttresses in order to provide climate control. The right-hand photo in photo 5.1 shows an example of a buttress dam. Note that the spillway is also a buttress type structure.



**Photo 5.1: Examples of gravity (RCC) and buttress dams**

**Arch and Cupola dams:** These dams function structurally as horizontally laid out arches that transfer the water pressure on the upstream face into the abutments rather than into the foundation. Arch dams can be designed with a constant radius over the dam height, or with varying radii (Cupola dams). Arch dams with a constant radius have a vertical and “straight” cross-section. These dams will be subject to considerable vertical strain forces since the deformation of the dam will tend to be greatest in the vertical centre of the dam. This requires that the dam be heavily reinforced to avoid cracking with accompanying leakage.

The Cupola dam is designed to have only compression forces for all directions and at all sections. This requires the radius of the curvature to vary over the dam height, which produces a curved vertical cross-section.

The arch and cupola dams are structurally efficient and greatly reduce the required volume of concrete. They require, however, a narrow valley topography and strong foundation rock in the abutments. In photo 5.2 an example of an arch dam is shown, and in figure 5.2 the typical geometry for single curvature arch dams versus double curvature cupola dams is displayed.





Photo 5.2: Example of an arch dam

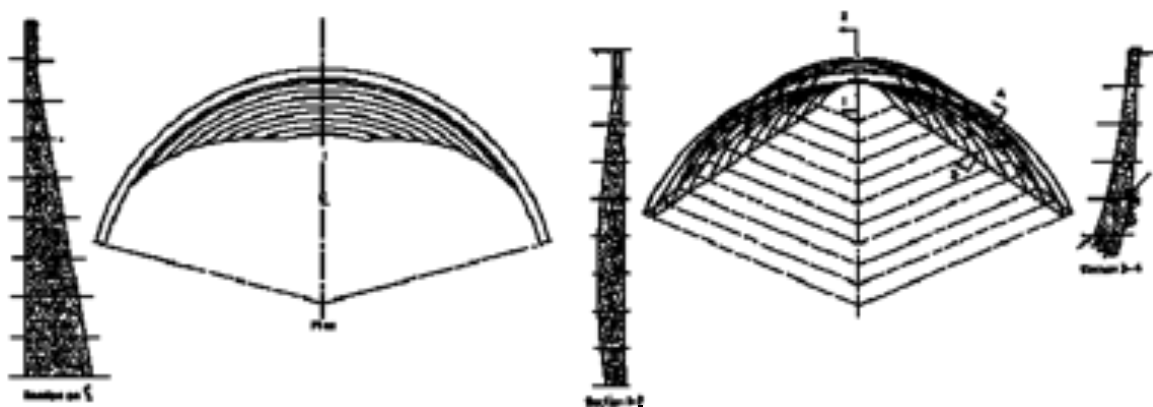


Figure 5.2: Typical geometry for arch and cupola dams (single curvature arch dam to the left)

### 5.2.3 Other Dam types

Another type of concrete dam is the **spillway dam**, which can be gated or ungated. A gated dam with large spillway openings compared to the dam height is often designed to function as a buttress dam, whereas higher spillway dams with relatively small spillway openings normally are designed to function as a gravity dam.

An ungated spillway dam is often referred to as a weir for lower dam heights. Weirs and spillways are described in more detail below.

An old dam type still prevailing is the **masonry dam**. This dam was prevalent during the early days of industrialization, utilizing the building techniques present at that time. The masonry structure functioned as the load bearing structure and water tightness was provided by either vertical timber sheeting on the upstream face or by filling impervious soils upstream of the masonry structure. Figure 5.3 shows an example of a masonry dam, with an upstream wall. In many ways these dams

resemble the CFRD, a development in embankment dams, and they share a number of advantageous characteristics.

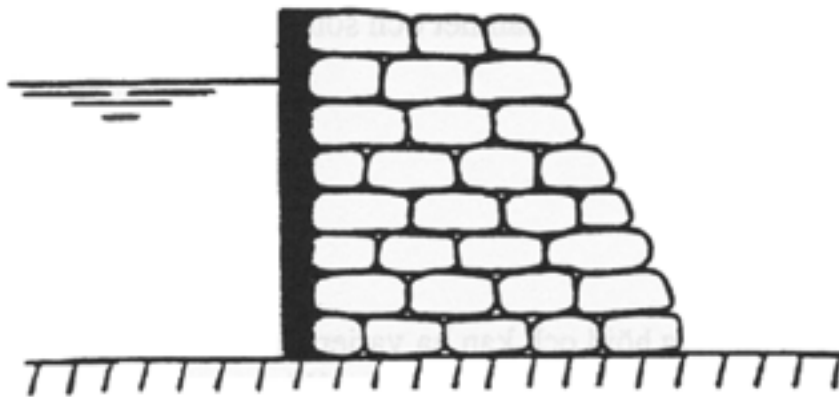


Figure 5.3: Masonry dam with vertical concrete upstream wall

**Timber dams:** These dams can still be found although due to their limited durability they are becoming increasingly scarce. These dams were constructed in two ways, as is shown in figure 5.4.

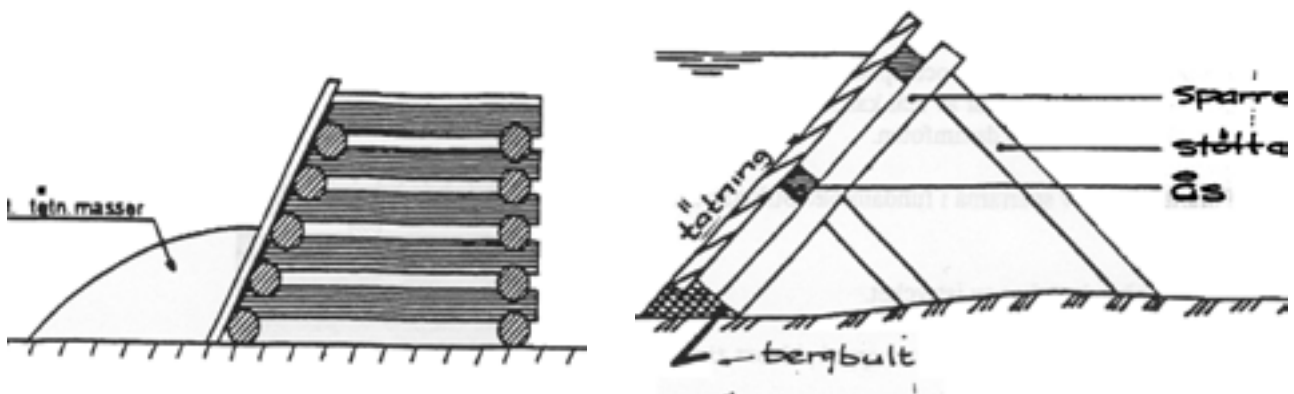


Figure 5.4: Typical timber dams

5.2.4 Loads and stability for concrete dams

In figure 5.5, the typical loads acting on concrete dams are shown. H denotes horizontal loads and V vertical loads. The horizontal loads are: 1; Lateral water pressure, 2; pressure from soil or deposited sediments, 3; Ice pressure, 4; Loads from floating objects and debris, 5; downstream water pressure, 6; dynamic acceleration from earthquakes, 7; incremental water pressure during earthquakes. The vertical loads are: 1; self-weight of the dam, 2; weight of water on inclined upstream surface, 3; uplift pressure from pore water, 4; dynamic load from earthquakes. There is also a small vertical load corresponding to the weight of water on the inclined downstream slope.

The understanding of uplift pressures and their importance for gravity dams has gradually increased. The very existence of uplift pressures was not known until the beginning of the 20<sup>th</sup> century. For the first gravity dams, made as masonry dams, uplift pressures were basically

eliminated due to the effective drainage provided by the porous structure of the masonry. As masonry was replaced by concrete in new dams these dams were designed applying the same well-proven dimensions used for masonry dams, which in many cases led to failure of the dams.

Modern concrete dams provide drainage in the form of drainage galleries, by drilling drainage holes into the foundation rock. Using grouting curtains reduces foundation leakage. These measures can be effective, but require maintenance. Concrete dams built as late as in the 1980's regularly show weaknesses due to the very optimistic assumptions regarding uplift pressures and the ineffectiveness of individual counter measures.

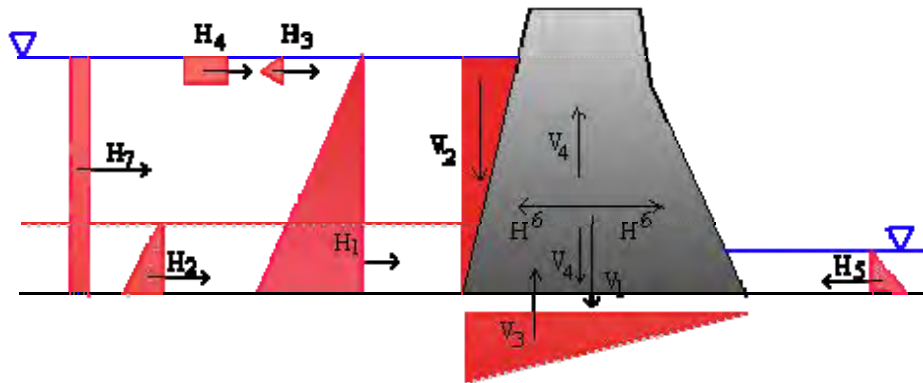


Figure 5.5: Loads on concrete dams

Concrete dams are designed for:

- Stability against rotation and overturning
- Stability against translation and sliding
- Over-stress and material failure

### 5.2.5 Dam Safety

Dams have been identified as “the single man-made structures capable of causing most deaths”. Hazards with dam failure have largely been associated with large dams and reservoirs, but depending on localization and circumstances even smaller and medium sized dams and reservoirs can be potentially dangerous, and considering their large number they do pose a significant threat to health and environment. In Sweden, for example, the only fatality as a result of dam failure was caused by the failure of a dam less than 4m high. Photo 5.3 shows two photos of the failure of a “small” dam. The left photo shows the breach and the right photo show the damage downstream.

In order to identify potentially hazardous dams most countries now employ a classification system for dams, requiring dam owners to classify their dams. The hazard level is described and identified subjectively using terms such as low, significant and high (USACE 1975).

Dam safety can be improved by installation of monitoring systems, performing reviews and undertaking dam inspections on a regular basis.



**Photo 5.3: Failure of a small dam, the breach and the flooding downstream**

### 5.3 Weirs and spillways

A dam failure can have severe effects downstream of the dam. During the lifetime of a dam different flow conditions will be experienced and a dam must be able to safely accommodate high floods that can exceed normal flow conditions in the river by orders of magnitude. For this reason carefully designed overflow passages are incorporated in dams or weirs as part of the structure. These passages are known as *spillways*. Due to the high velocities of the spilling water, some form of energy dissipation is usually provided at the base of the spillway.

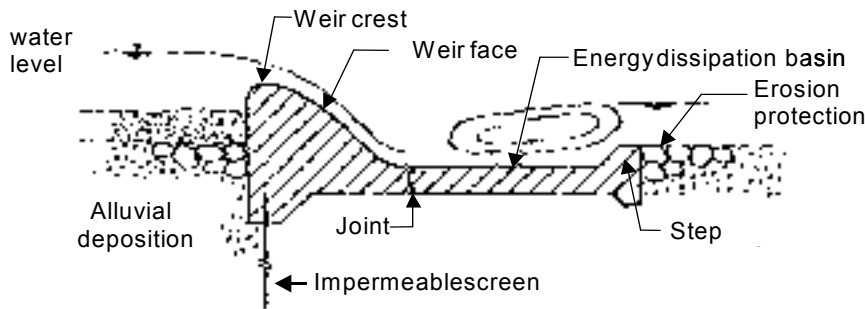
The large majority of small hydro schemes are of the run-of-river type, where electricity is generated from discharges larger than the minimum required to operate the turbine. In these schemes a low diversion structure is built on the streambed to divert the required flow whilst the rest of the water continues to flow over it. Such a structure is commonly known as a *weir*, whose role is not to store the water but to increase the level of the water surface so the flow can enter into the intake.

Weirs and spillways can be subdivided into *fixed* and *mobile* structures (Figure 5.6). Smaller fixed structures are generally referred to as weirs, whereas larger structures are often referred to as spillways. Spillways are often divided into ungated and gated spillways, corresponding to fixed and mobile structures, the ungated spillway in fact being a large-scale weir.

Fixed storage structures, such as weirs and ungated spillways have the advantage of security, simplicity, easy maintenance, and are cost effective. However, they cannot regulate the water level and thus both the water level and energy production fluctuates as a function of discharge.

Mobile storage structures such as gated spillways can regulate the water level such that it stays more or less constant for most incoming flow conditions. Depending on gate configuration and discharge capacity they may also be able to flush accumulated sediment downstream. These structures are generally more expensive than fixed structures, for both construction and maintenance, and their functioning is more complicated.

### Fixed structure



### Mobile structure

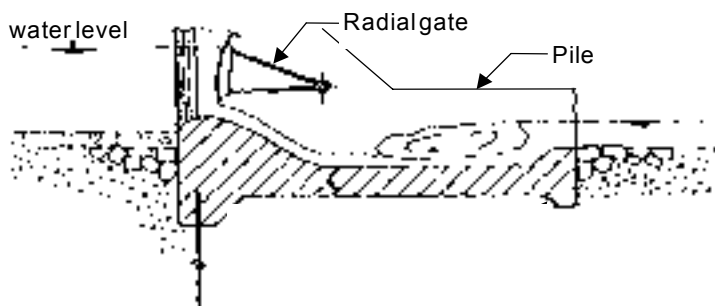


Figure 5.6: Fixed and mobile spillway structures

#### 5.3.1 Weirs

Weirs can be constructed perpendicular, angular or lateral compared to the river axis. Most often the weir crest is rectilinear and perpendicular to the river axis. For relatively low downstream water levels, the weir controls the flow and defines the relationship between the upstream water level and the discharge. As a function of the type of weir, different discharge relationships are obtained as indicated in Figure 5.7.

The sharp-crested weir is easy to construct and relatively cost-effective. Its discharge is defined by means of a coefficient  $C_d$ . Special attention has to be paid to the shape of the downstream face of the upper part of the weir in order to obtain sufficient aeration between the lower nappe (sheet of water that flows over the weir) of the jet and the structure. If the lower nappe of the jet sticks to the structure, vibrations may be transferred from the flow to the structure.

The broad-crested weir is often applied for temporary structures or for structures of secondary importance, such as in case of temporary flow diversion. Its design is simple and cost-effective. The hydraulic conditions are far from optimal, expressed by a low discharge coefficient and the presence of under-pressures along the weir crest and downstream face. The discharge depends on the form of the structure.

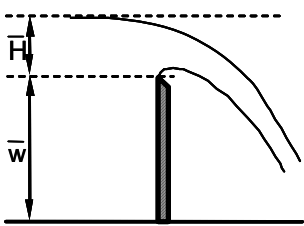
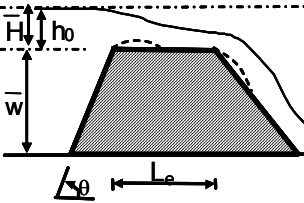
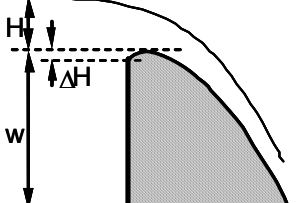
Type	Design	Discharge relationship	Characteristics
Sharp-crested weir		$Q = b \cdot \bar{C}_d \cdot H^{3/2} \cdot \sqrt{2g}$ $\bar{C}_d = 0.42$	<p>Simple design</p> <p>Cost effective</p>
Broad-crested weir		$Q = b \cdot c_e \cdot \bar{C}_d \cdot H^{3/2} \cdot \sqrt{2g}$ $\bar{C}_{d,mean} = 0.42$ $c_e = 1 - \frac{2\sin\theta}{9(1+\xi_e^4)}$ $\xi_e = \frac{H-w}{L_e}$	<p>Simple design, underpressures on crest</p> <p>Cost effective</p>
Ogee weir		$Q = b \cdot C_{dD} \cdot H^{3/2} \cdot \sqrt{2g}$ $C_{dD} = 0.494$ <p>(for <math>H = H_D</math>)</p>	<p>Highest discharge</p> <p>Costly design</p>

Figure 5.7: Discharge characteristics for weirs

The ogee weir is hydraulically the most ideal solution giving the highest discharge coefficient. Its curved shape is defined by the jet trajectory that would appear for the design discharge  $H_D$ . For lower or higher discharges, over- or under-pressures will appear along the downstream face. For discharges much higher than the design discharge, these under-pressures may lead to cavitation and damage to the downstream concrete face. Recent work suggests fortunately that separation will not occur until  $H > 3H_D$ . The U.S. Waterways Experimental Station has provided a set of profiles that have been found to agree with actual prototype measurements. The exact relationship between the discharge coefficient and the ratio  $H/H_D$  can be found in Sinniger & Hager (1989).

For downstream water levels that are equal to or higher than the spillway crest level, the spillway becomes progressively submerged and its corresponding discharge decreases. Furthermore, in presence of piles, the governing discharge will depend on the shape and dimensions of the piles. All these aspects influence the functioning of a spillway and for a detailed and correct design; the reader is referred to classical works in this field, such as Sinniger & Hager (1989).



Photo 5. 4. Ogee weir

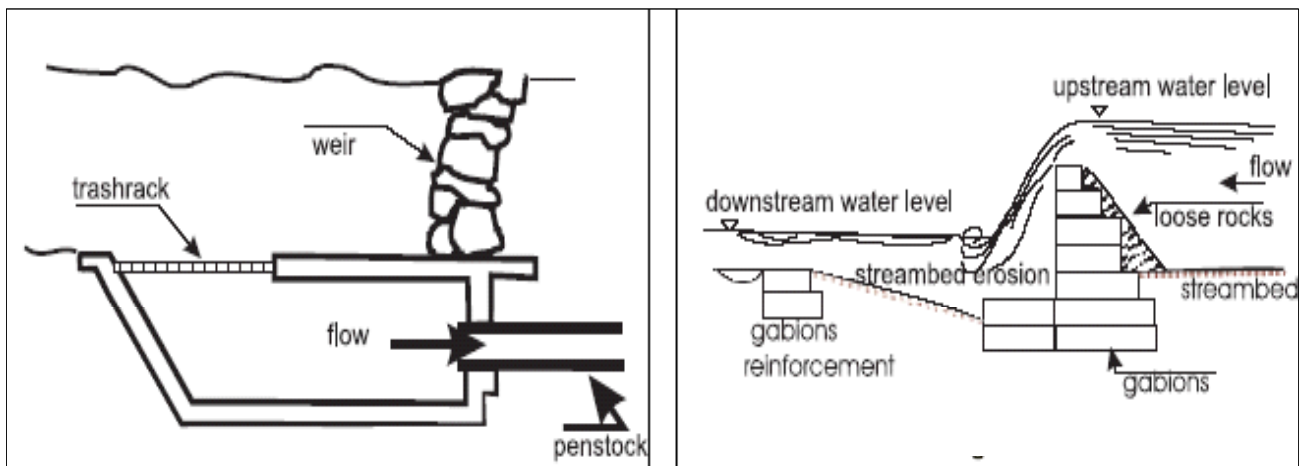


Figure 5.8: Weir configurations

### 5.3.2 Gated Spillways

The installation of mobile elements on dams or weirs allows control of the flow conditions without changing the water level. This is performed by means of gates, which are designed such that, when the gate is fully open (and the structure functions as if it were fixed) the discharge has to pass the structure without noticeable water level increase upstream. Gate operation needs permanent maintenance and an external energy source. As a result, there is a risk that the gate remains blocked during floods.

The most used types of gates are presented in Figure 5.9. Depending on the type of gate, the possible gate movements are rotating, sliding or turning. The discharge through the gates depends not only on the type of gate and the relative gate opening and gate lip angle, but also on the shape of the supporting weir.

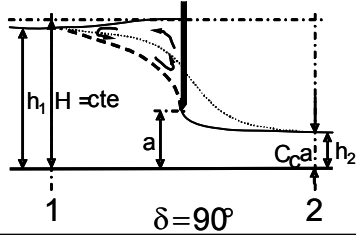
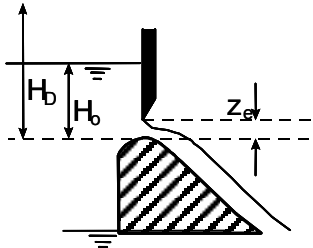
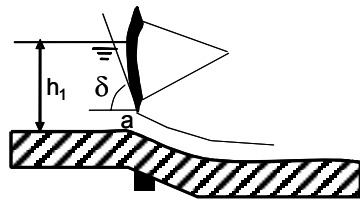
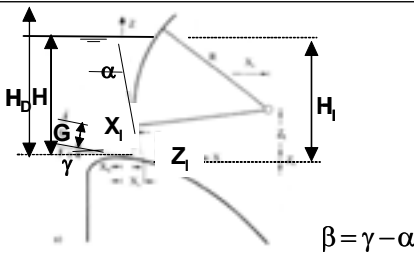
Type	Position	Design	Discharge relationshi
Flat gate	rectangula canal		$Q = ab \cdot C_d \cdot \sqrt{2gh_1}$ $C_d = C_{d0} - \exp\left[\frac{a}{2 \cdot h_1} \left(1 - \frac{\delta^2}{b}\right)\right]$ $C_{d0} = 0.98 \cdot \left[\frac{4 + 5 \cdot e^{-0.76\delta}}{9}\right]$
	ogeweir		$\frac{Q_g}{Q_b} = \left[\frac{H_b^{3/2}}{H_b} - \left(\frac{H_b}{H_b} - \frac{z_e}{H_b}\right)^{3/2}\right] \cdot \left(\frac{1}{6} + \frac{z_e}{H_b}\right)^{1/9}$ $Q_D = b C_{dD} \cdot H^{3/2} \cdot \sqrt{2g}$ $C_{dD} = 0.494$
Sectoror radialgate	rectangula canal		$Q = ab \cdot C_d \cdot \sqrt{2gh_1}$ $C_d = C_{d0} - \exp\left[\frac{a}{2 \cdot h_1} \left(1 - \frac{\delta^2}{b}\right)\right]$ $C_{d0} = 0.96 \cdot \left[\frac{4 + 5 \cdot e^{-0.76\delta}}{9}\right]$
	ogeweir		$Q = H_b \cdot b \cdot G \cdot C_{dG} \cdot \sqrt{2gH_b}$ $C_{dG} = 0.90 \cdot \left(1 - \frac{\beta}{27^\circ}\right) \cdot \left(\frac{H}{H_b}\right)^{0.12}$ $G = \left[1 - \frac{2}{g} \cdot \left(\frac{x_1}{H_b}\right)^{3/2}\right] \cdot \left[\frac{z_1}{H_b} + \frac{1}{2} \cdot \left(\frac{x_1}{H_b}\right)^{1.85}\right]$ $\beta = \gamma - \alpha$

Figure 5.9: Discharge characteristics for gated spillways

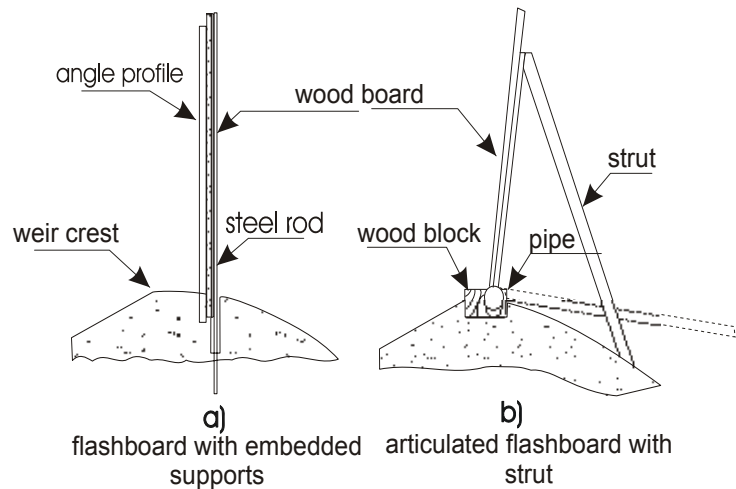
More detailed design accounts also for the shape of the gate lip. Furthermore, the above-presented discharges are only valid for un-submerged flow conditions. Similar to the fixed structures, when the downstream water level becomes equal to or higher than the crest level, the mobile structure becomes progressively submerged and the corresponding discharge decreases. For more information, the reader is encouraged to consult classical textbooks on this subject.

5.3.3 Other spillways

Flashboards

To raise the water level slightly behind the weir to ensure adequate depth of water at the intake, without endangering the flooding of the upstream terrain, *flashboards* may be installed on the crest of the weir (Figure 5.10). The flashboards are commonly made of wood and supported by steel pins embedded in steel sockets (pipes cut down to size) in the spillway crest. The flashboards have to be removed by hand during flood flows so that high water levels do not flood the upstream terrain, an operation that in such circumstances is very difficult. The articulated flashboard is somewhat easier to remove.





**Figure 5.10: Flashboards, articulated & embedded**

**Photo 5.5: Articulated flashboard**

Inflatable weirs

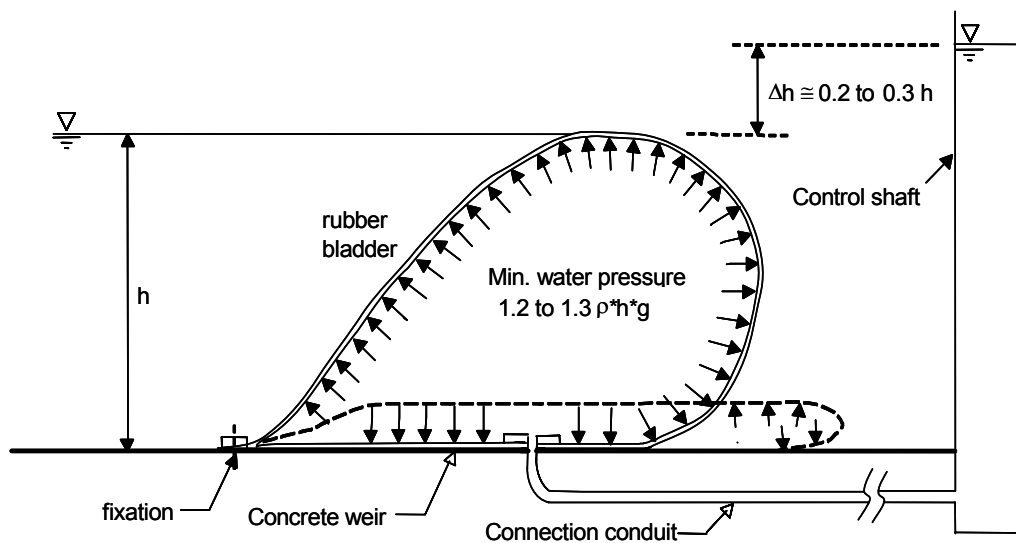
Another method, capable of remote control, is the *inflatable weir*, which employs a reinforced rubber bladder instead of concrete, steel or wood flashboards. This offers an alternative to more conventional methods of weir construction, with the inherent advantages of low initial cost, simple operation and minimal maintenance.

In effect, inflatable weirs are flexible gates in the form of a reinforced, sheet-rubber bladder inflated by air or water, anchored to a concrete foundation (Figure 5.11) by anchor bolts embedded into the foundation. Like any other gate, the inflatable weir needs a mechanism by which it is opened and closed. The weir is raised when filled with water or air under pressure. An air compressor or a water pump is connected, via a pipe, to the rubber bladder. When the bladder is filled the gate is raised; when it is deflated the weir lies flat on its foundation, in a fully opened position. The system becomes economic when the width of the weir is large in relation to the height.

When the management and operational safety of the system is rather critical, the use of inflatable weirs can give substantial advantages over conventional systems. An electronic sensor monitors the upstream water level and the inner pressure of the bladder. A microprocessor maintains a constant level in the intake entrance by making small changes in the inner pressure of the bladder. To avoid flooding land, a similar device can regulate the inflatable weir regulated to correspond to a pre-set upstream water level.

Inflatable gate control systems can be designed to fully deflate the bladder automatically in rivers prone to sudden water flow surges. On a typical weir, two meters high and thirty meters wide, this can be done in less than thirty minutes. Photo 5.6 illustrates a new type of inflatable weir - patented by Obermeyer Hydro - where the sheet rubber incorporates a steel panel that behaves as a flashboard, which is quickly and easily moved in the event of sudden floods. By controlling the pressure in the rubber blade the steel panels may be more or less inclined, varying the level of the water surface. The system incorporates an additional advantage: the rubber blade is always protected against boulders carried during flood flows (buoyancy causes heavy boulders to lose a portion of their weight in water, making it easier for the flood flow to carry them downstream). A

synthetic rubber flap anchored to one of the panels closes the free space between panels or between panel and the buttress.



**Figure 5.11: Inflatable weir**



**Photo 5.6: Flashboard controlled by inflatable rubber bladder**

Fusegates

In large installations, but also sometimes in small ones, it is advisable to place fusegates, such as those supplied by Hydroplus<sup>2</sup>. In the event of a major flood, when the water reaches a pre-set level, one or more of the fusegates (basically hinged structures) will tilt to increase the section of the spillway (Photo 5.7).



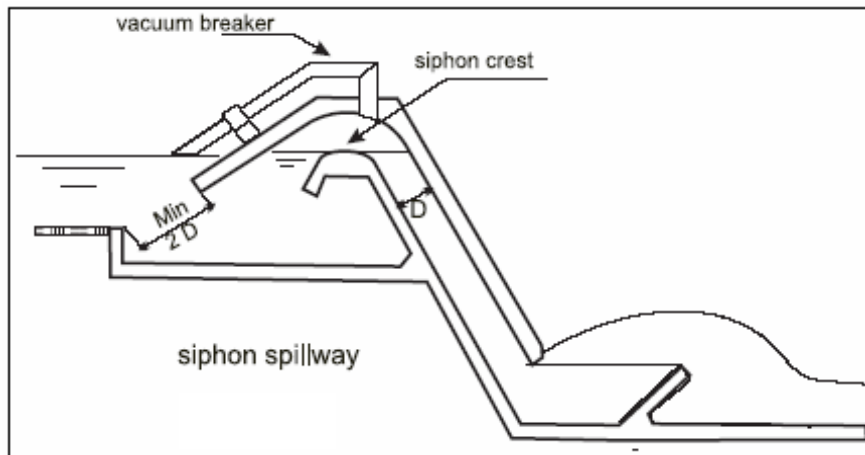
**Photo 5.7: Hydroplus fusegates**

### Siphon spillways

Alternatively where space available for the spillway is limited, a siphon spillway or a shaft spillway may be used. Both solutions help to keep the upstream water level within narrow limits. A siphon spillway is basically a curved enclosed duct (Figure 5.12). When the water level rises above the elbow of the siphon, water begins to flow down the conduit just as in an overflow, but it is when it rises further that the siphon is primed and increases the discharge considerably. Usually siphons are primed when the water level reaches or passes the level of the crown, but there are designs where priming occurs when the upstream level has risen only to about one third of the throat height.

If badly designed, the siphon process can become unstable. At the beginning the siphon discharges in a gravity mode, but when the siphon is primed the discharge suddenly increases. Consequently the reservoir level drops, the siphon is de-primed and the discharge is reduced. The level of the reservoir increases anew until the siphon primes again, and the cycle of events is repeated indefinitely, causing severe surges and stoppages. Multiple siphons with differential crest heights or aerated siphons can be the solution to this problem. When the siphon is primed the flow through a siphon spillway is governed, as in penstocks, by Bernoulli's equation. Assuming that the velocity of water in the conduit is the same at the inlet and outlet, the head loss may be calculated from the formulae in Chapter 2, paragraph 2.2.1.

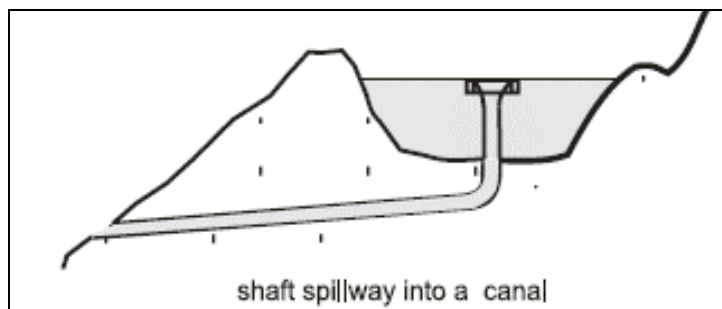
If the pressure at the crown of the siphon drops below the vapour pressure, the water vaporises forming a large number of small vapour cavities, which entrained in the flow, condense again into liquid in a zone of higher pressure. This phenomenon is known as cavitation and it can be extremely damaging. To avoid it, the distance between the crown of the siphon and the maximum level at the reservoir, depending on height above sea level and prevailing barometric pressure, should normally not exceed 5 m. Further details on this kind of spillway can be found in the literature<sup>3</sup>.



**Figure 5.12: Schematic layout of siphon spillway**

Shaft (or Morning glory) spillways

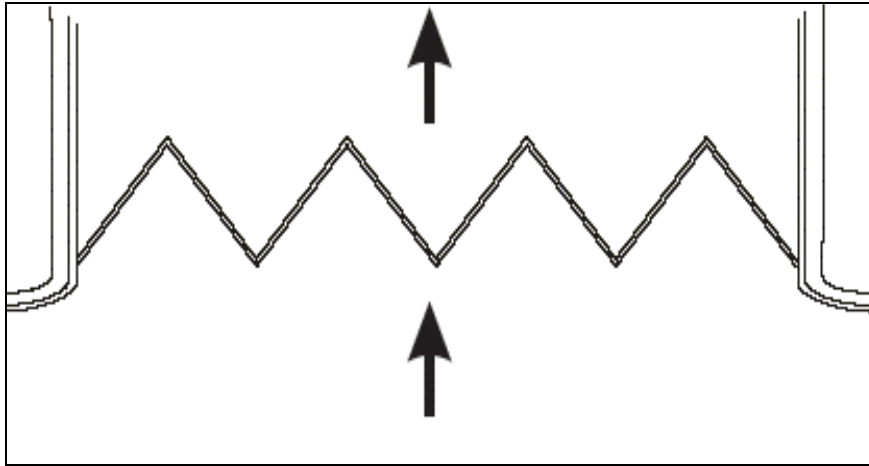
Shaft spillways are rarely used in small scale-hydro. As illustrated in Figure 5.13, a shaft spillway incorporates a funnel-shaped inlet to increase the length of the crest, a flared transition which conforms to the shape of the nappe as in the overflow spillway though it is sometimes stepped to ensure aeration, a vertical shaft and an outlet tunnel that sometimes has a slight positive slope to ensure that at the end it never flows full. The US Bureau of Reclamation reports (USBR) 6 and 7 describe the design principles for these spillways.



**Figure 5.13: Schematic view of morning glory (shaft) spillway**

Labyrinth weir

In some small hydropower schemes (e.g. small schemes in an irrigation canal) there is not enough space to locate a conventional spillway. In these cases, U shaped or labyrinth weirs (Figure 5.14) should help to obtain a higher discharge in the available length.



**Figure 5.14: Labyrinth weir**

## **5.4 Energy dissipating structures**

The discharge from the aforementioned fixed or mobile structures is usually supercritical at the outlet. The corresponding high flow velocities and turbulence may produce severe erosion at the toe of the structure, especially if the riverbed is not erosion resistant, such as for example in the case of silt, clay, loose sand, gravel or even fractured rock.

To avoid such damage, several structural solutions may be applied, some of them being very costly. The most often used solutions are:

- Stilling basin
- Baffled apron drop
- Plunge pool
- Chute cascades

Most of these structures dissipate the flow energy by the formation of a hydraulic jump, which dissipates a lot of energy over a relatively short distance. The design and construction of energy dissipating structures is quite complex and vast and the reader is encouraged to contact specialized engineers. More detailed information can be found for example in Vischer & Hager (1995).

In RCC-dams the stepped chute downstream of the spillway has proven effective in reducing flow velocities and reducing the dimensions of the subsequent stilling basin.

## **5.5 Intake structures**

### **5.5.1 General**

A water intake must be able to divert the required amount of water into a power canal or into a penstock without producing a negative impact on the local environment and with the minimum possible head losses. Also, a major challenge consists of handling debris and sediment transport. The intake serves as a transition between a stream that can vary from a trickle to a raging torrent,

and a controlled flow of water both in quality and quantity. Its design, based on geological, hydraulic, structural and economic considerations, requires special care to avoid unnecessary maintenance and operational problems that cannot be easily remedied and would have to be tolerated for the life of the project.

A water intake designer should take three criteria into consideration:

- Hydraulic and structural criteria common to all kind of intakes
- Operational criteria (e.g. percentage of diverted flow, trash handling, sediment exclusion, etc.) that vary from intake to intake
- Environmental criteria characteristics of each project (eg requiring fish diversion systems, fish passes, etc).

The location of the intake depends on a number of factors, such as submergence, geotechnical conditions, environmental considerations (especially those related to fish life) sediment exclusion and ice formation, where necessary. The orientation of the intake entrance to the flow is a crucial factor in minimising debris accumulation on the trashrack, a source of possible future maintenance problems. The best disposition of the intake is with the screen at right angles to the spillway so, that during flood seasons, the flow pushes the debris over its crest. The intake should not be located in an area of still water, far from the spillway, because the eddy currents common in such waters will accumulate trash at the entrance.

The intake should be equipped with a trashrack to minimise the amount of debris and sediment carried by the incoming water; a settling basin where the flow velocity is reduced, to remove all particles over 0.2 mm; a sluicing system to flush the deposited silt, sand, gravel and pebbles with a minimum of water loss; and a spillway to divert the excess water.

### 5.5.2 Intake types

The first thing for the designer to do is to decide what kind of intake the scheme needs. These can be classified according to the following criteria:

- *Power intake*: The intake supplies water directly to the turbine via a penstock. These intakes are often encountered in lakes and reservoirs and transfer the water as pressurized flow.
- *Conveyance intake*: The intake supplies water to other waterways (power canal, flume, tunnel, etc.) that usually end in a power intake (Figure 1-1 Chapter 1). These are most frequently encountered along rivers and waterways and generally transfer the water as free surface flow.

Conveyance intakes along rivers can be classified into lateral, frontal and drop intakes. The main characteristics of these three types are summarized in Table 5.1.

Table 5.1: Intake characteristics

		River slope	River width B	Plan view of river	Sediment transport
Lateral intake	in outer river bend	$0.001\% < J < 10\%$	All widths	Curved path is optimal	Strong bedload, small suspended transport ( $Q_{eq} < Q_{cr}$ )
	with gravel deposition canal	$0.01\% < J < 10\%$	$B < 50$ m	Possible rectilinear path if countermeasures	Strong bedload with continuous flushing, strong suspended load
Frontal intake	with gravel deposition tunnel	$0.01\% < J < 10\%$	$B < 50$ m, ( $B < 500$ m for economical dams/weirs)	Rectilinear is optimal, curved path is possible if countermeasures	Strong bedload with continuous flushing, very strong suspended load
Drop intake		$J > 10\%$ favorably, possible already at 2.5%	$B < 50$ m, ( $B < 500$ m is possible for dams/weirs over part of river width)	Rectilinear	Strong bedload (only large grain sizes)

The lateral intake functions by using a river bend or by using a gravel deposition channel. The former is presented in Figure 5.15. This intake favourably applies the presence of a strong secondary current along the outer bend of the curved river. This secondary current prevents bedload from entering the intake. The installed discharge  $Q_{ep}$  has to be smaller than 50 % of the critical river discharge  $Q_{cr}$ , where the latter is defined as the discharge for which the bedload transport starts.

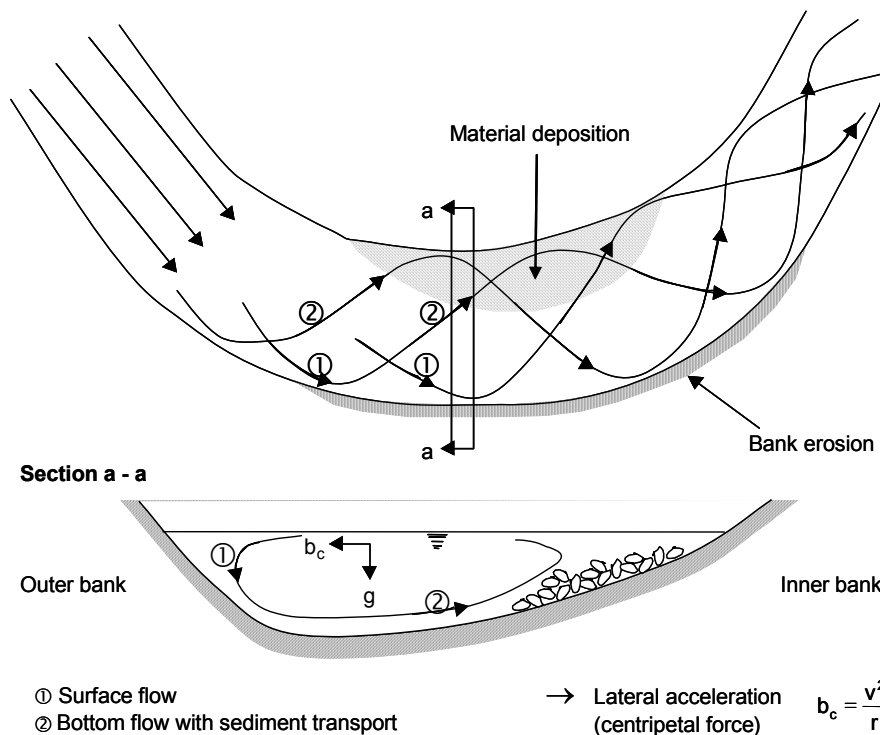
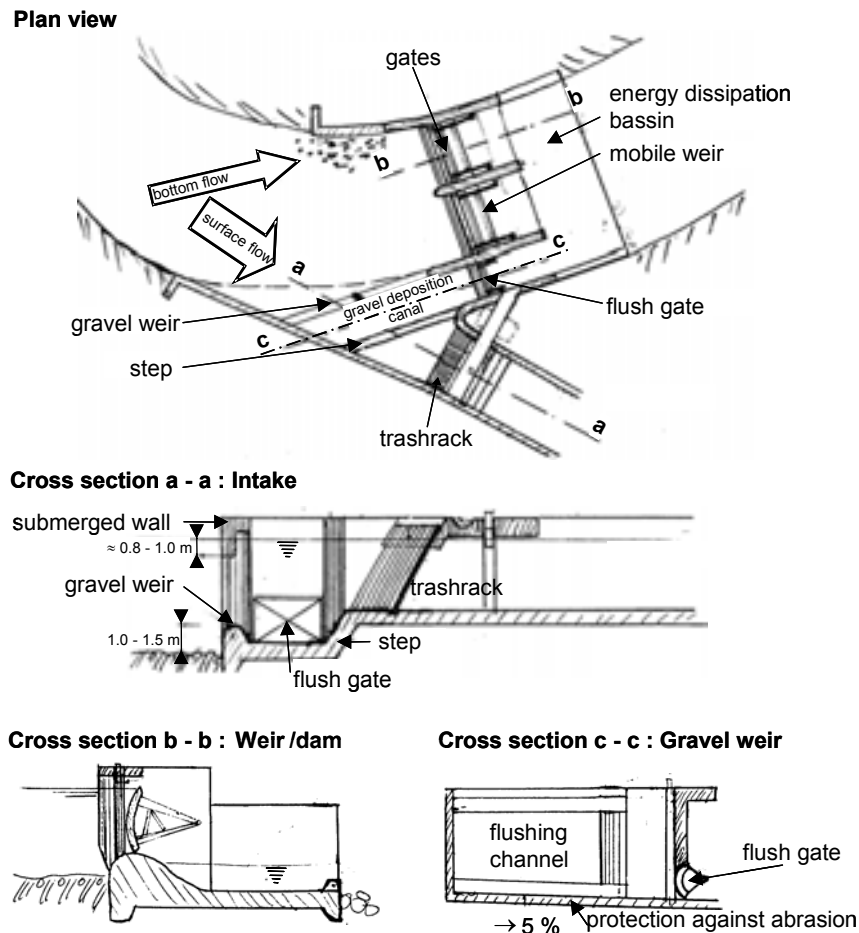


Figure 5.15: Secondary currents in river bends

The latter type of lateral intake uses a gravel deposition canal in front of the intake in order to prevent both bed and suspended load from entering the intake. Hence, there is no discharge restriction. The channel makes use of a gravel weir of minimum 1-1.5 m, as indicated in Figure 5.13. Furthermore, its slope should be at least 2%, preferably 5%. The channel bottom has to be

protected against abrasion (using high quality concrete, stones, etc.). A partially submerged wall (0.8-1.0 m submersion) is installed in order to prevent debris from entering the intake.

The main elements of the lateral intake structure are presented in Figure 5.16: a mobile weir/dam, gravel deposition channel and intake with trashrack.



**Figure 5.16: Typical layout of lateral intake**

The frontal intake is always equipped with a gravel deposition tunnel and is well adapted for rectilinear river reaches. The deposition tunnel has to be flushed in a continuous manner and the maximum river width is 50 m. A major advantage of this type of intake is its ability to handle large quantities of both bed and suspended load. However, this needs continuous flushing and thus large losses of water. The frontal intake is largely applied in regions with very large bed and suspended loads, such as for example in India and Pakistan. In Europe, its application is largely restricted.

The drop intake is generally used in steep sloped rivers, such as torrents, and for rectilinear reaches. The "French" drop intake (Figure 5.17) is essentially a canal built in the streambed, stretching across it and covered by a trashrack with a slope greater than the streambed slope. The trashrack bars are oriented in the direction of the streamflow. Photo 5.8 shows a drop intake installed in a mountain stream in Asturias (Spain).



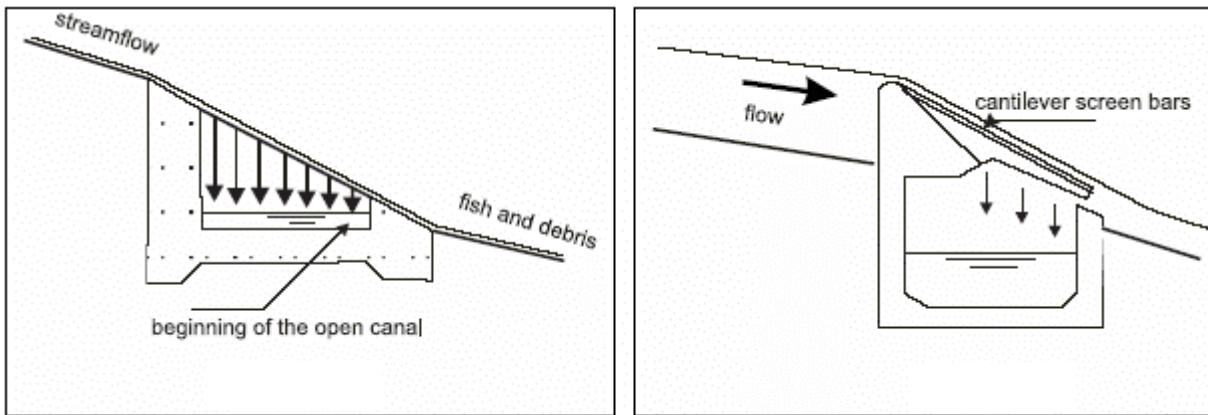


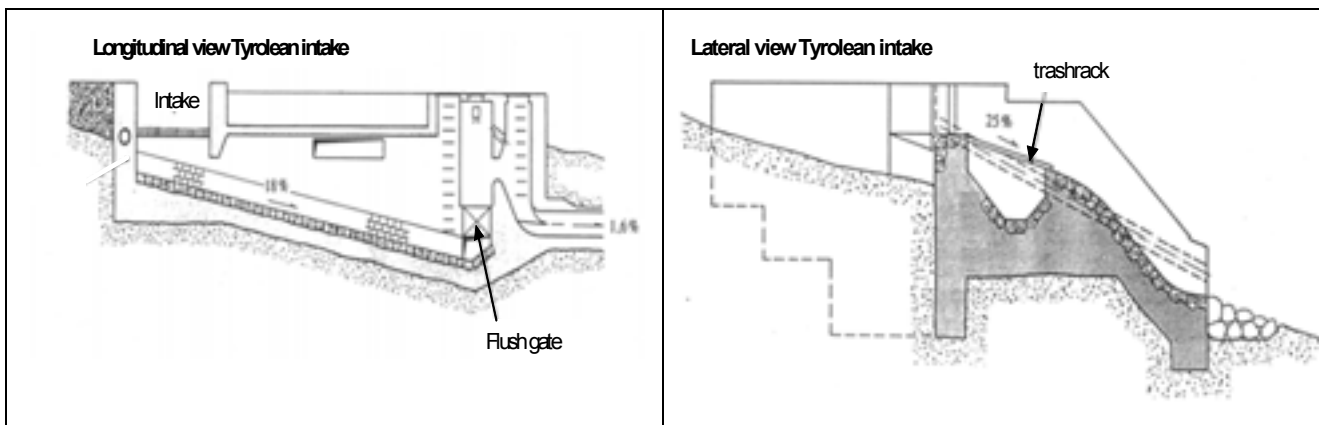
Figure 5.17: Secondary current along the outer bend of a curved river.



Photo 5.8: Drop intake

The Coanda type screen is an advanced concept of the drop intake, incorporating the "Coanda effect", well known in the ore separation industry, to separate fish and debris from clean water. Essentially it consists of a weir with a downward sloping profiled surface of stainless steel wire screen mesh on the downstream side and a flow collection channel below the mesh - as in the drop intake. The mesh wires are held horizontal -unlike the drop intake- and are of triangular section to provide an expanding water passage. Water drops through the mesh with debris and fish carried off the base of the screen. The screen is capable of removing 90% of the solids as small as 0.5 mm, so a silt basin and sediment ejection system can be omitted. The intake is patented by AQUA SHEAR and distributed by DULAS 11 in Europe.

In the Alps, a drop intake has been developed that is particularly adapted to very steep torrents in high mountainous regions with difficult access, called the "Tyrolean" intake (Figure 5.18).



**Figure 5.18: “Tyrolean” intake**

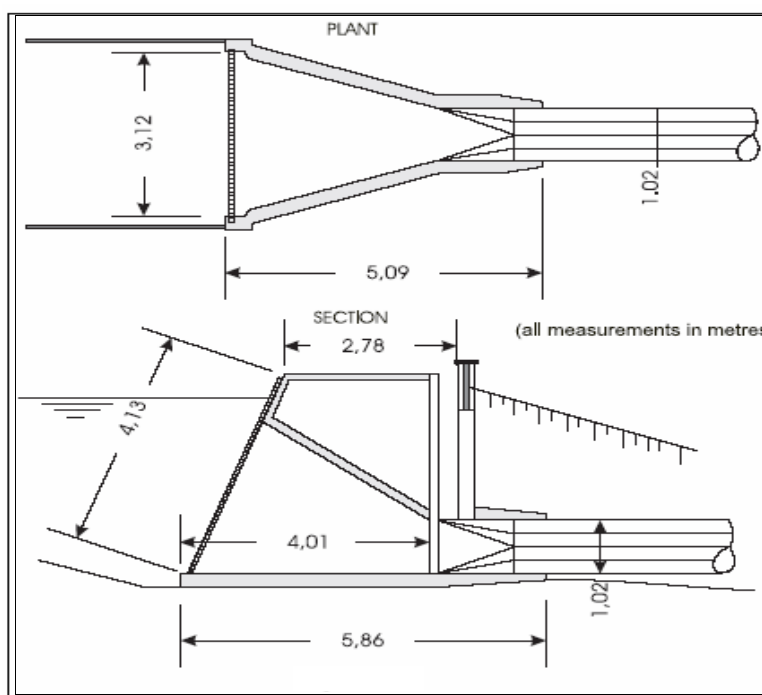
Power intakes are mostly used on lakes and reservoirs. The water is transferred under pressure and the problems associated with these kinds of intakes are different than for conveyance intakes. For example, sediments are much less able to enter the intake, although they may pose a problem by deposition in the lake itself. On the other hand, pressurized intakes with low pressure heads contain the risk of vortex formation at their entrance and thus the formation of air pockets inside the downstream conduit. This is discussed later on.

### 5.5.3 Head losses

For small hydro plants, *head losses* can be of huge importance to the feasibility of the project and should thus be minimized as much as possible. Accounting for the following issues can do this:

- Approach walls to the trashrack designed to minimise flow separation and head losses
- Piers to support mechanical equipment including trashracks, and service gates
- Guide vanes to distribute flow uniformly
- Vortex suppression devices
- Appropriate trashrack design

The velocity profile decisively influences the trashrack efficiency. The velocity along the intake may vary from 0.8 - 1 m/s through the trashrack to 3 - 5 m/s in the penstock. A good profile will achieve a uniform acceleration of the flow, minimising head losses. A sudden acceleration or deceleration of the flow generates additional turbulence with flow separation and increases the head losses. Unfortunately a constant acceleration with low head losses requires a complex and lengthy intake, which is expensive. A trade-off between cost and efficiency should be achieved. The maximum acceptable velocity dictates the penstock diameter; the need for a reasonable velocity of the flow approaching the trashrack dictates the dimensions of the rectangular section.



**Figure 5.19: French drop intake: a canal built in the streambed and covered by a trashrack**

The research department of "Energy, Mines and Resources" of Canada commissioned a study of entrance loss coefficients for small, low-head intake structures to establish guidelines for selecting optimum intake geometry. The results showed that economic benefits increase with progressively smoother intake geometry having multiplane roof transition planes prepared from flat form work. In addition, it was found that cost savings from shorter and more compact intakes were significantly higher than the corresponding disadvantages from increased head losses.

Analyses of cost/benefits suggests that the best design is that of a compact intake with a sloping roof and converging walls (Figure 5.19, alternative 2 in the study), whilst the length of the intake is unlikely to be the major factor contributing to the overall loss coefficient. The K coefficient of this transition profile was 0.19. The head loss (m) in the intake is given by:

$$\Delta H = 0.19 V^2/2g \tag{5.1}$$

where V is the velocity in the penstock (m/s). Head losses due to the trashrack depend on spacing and shape of the bars, orientation of the trashrack compared to the flow and eventual obstruction due to debris and are discussed in more detail below.

#### 5.5.4 Trashracks

One of the major functions of the intake is to minimise the amount of debris and sediment carried by the incoming water, so trashracks are placed at the entrance to the intake to prevent the ingress of floating debris and large stones. A trashrack is made up of one or more panels, fabricated from a series of evenly spaced parallel metal bars. If the watercourse, in the flood season, entrains large debris, it is convenient to install, in front of the ordinary grill, a special one, with removable and widely spaced bars (from 100 mm to 300 mm between bars) to reduce the work of the automatic trashrack cleaning equipment.

Trashracks are fabricated with stainless steel or plastic bars. Since the plastic bars can be made in airfoil sections, less turbulence and lower head losses result. The bar spacing varies from a clear width of 12 mm for small high head Pelton turbines to a maximum of 150 mm for large propeller turbines. The trashrack should have a net area (the total area less the bars frontal area) so that the water velocity does not exceed 0.75 m/s on small intakes, or 1.5 m/s on larger intakes, to avoid attracting floating debris to the trashrack. Trashracks can be either be bolted to the support frame with stainless steel bolts or slid into vertical slots, to be removed and replaced by stoplogs when closure for maintenance or repair is needed. In large trashracks it must be assumed that the grill may be clogged and the supporting structure must be designed to resist the total water pressure exerted over the whole area without excessive deformation.



Photo 5.9: Prefabricated booms

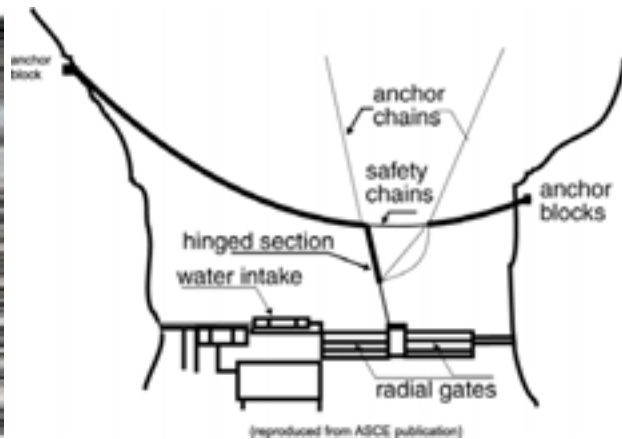


Figure 5.20: Trash boom layout

When the river entrains heavy debris, floating booms may be located ahead of the trashracks. The simplest boom consists of a series of floating pieces of timber connected end to end with cables or chains. However modern booms are built with prefabricated sections of steel and plastic (Photo 5.9) supported by steel cables. Their location is critical, because their inward bowed configuration does not lend itself to a self-cleaning action during flood flows. Figure 5.20 (reproduced from reference 11) shows a rather complex trash boom layout designed for a dual-purpose: preventing boats passing over the spillway and protecting the adjacent intake. A section of the boom is hinged at one end of the fixed section so that winches can handle the other end to let the trash pass downstream over the spillway, when large quantities are passing.

The trashrack is designed so the approach velocity ( $V_0$ ) remains between 0.60 m/s and 1.50 m/s. The maximum possible spacing between the bars is generally specified by the turbine manufacturers. Typical values are 20-30 mm for Pelton turbines, 40-50 mm for Francis turbines and 80-100 mm for Kaplan turbines.

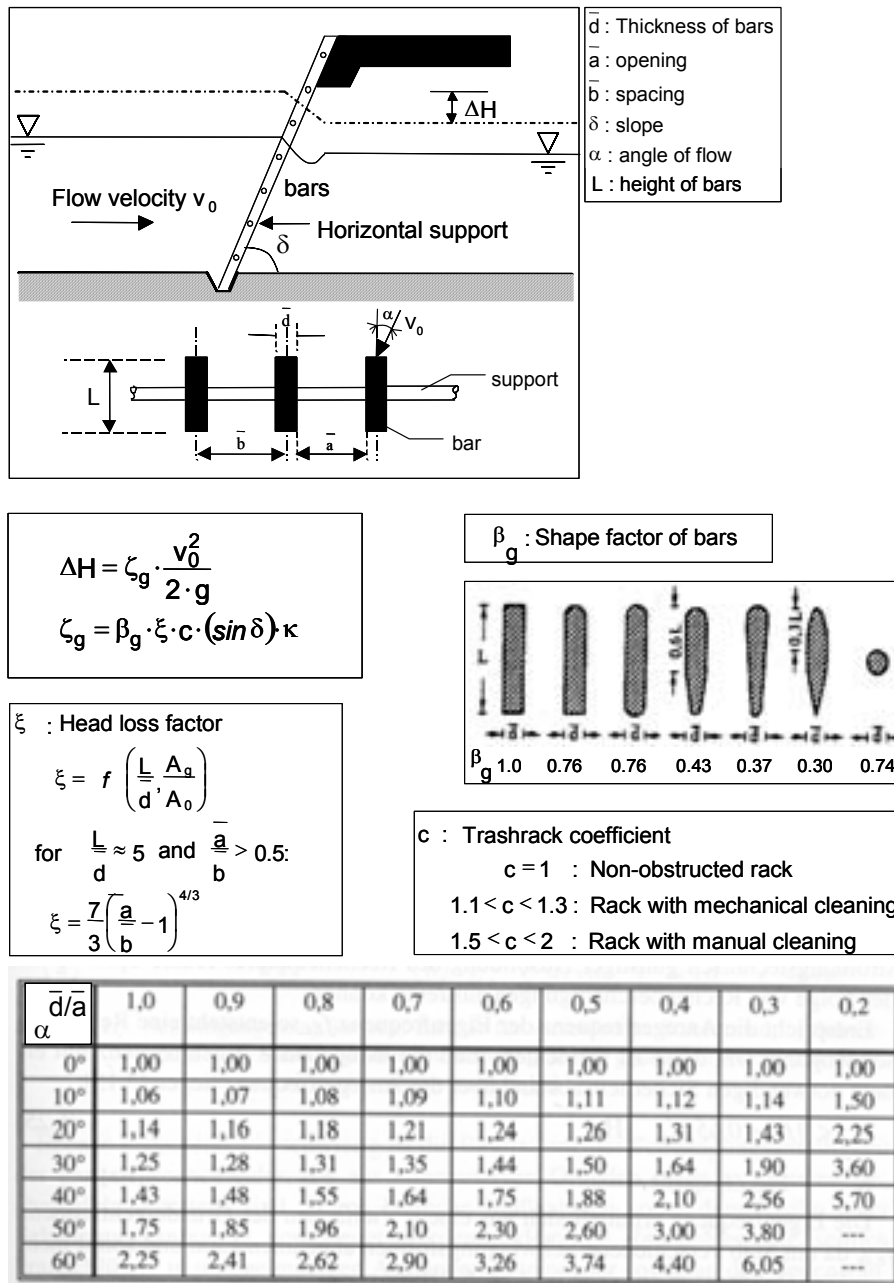
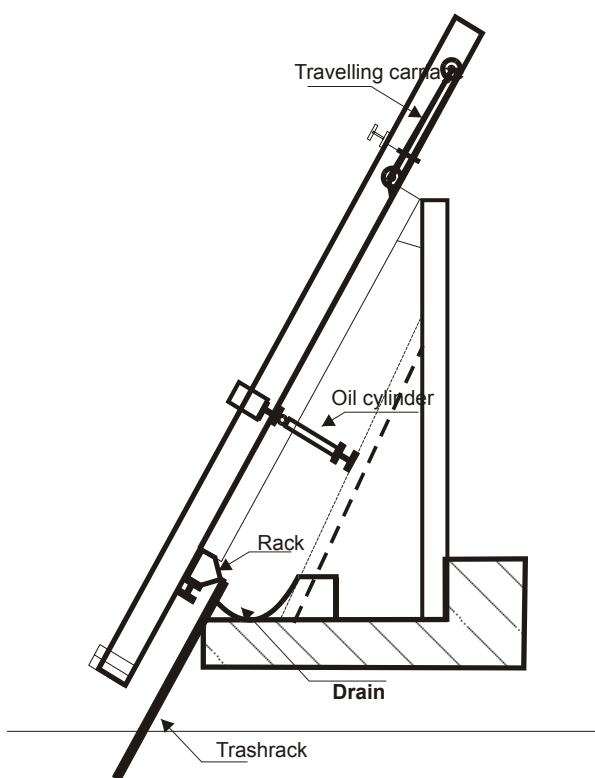


Figure 5.21: Formula for computing head losses

As can be seen, the head loss coefficient depends on several factors, such as for example the way of cleaning of the rack. The presented equations (Figure 5.21) are strictly only valid for rectangular bars, but experience has proven that they can also be used for other bar shapes. Cleaning of trashracks is very important to reduce possible head losses through the system. Manual cleaning is very difficult, especially during floods. Therefore, mechanical cleaning is recommended.

Another formula for computing head losses in clean trashracks is the Kirscher formula, detailed in Chapter 2, section 2.2.2.1. This formula is only valid when the flow approaches the screen at right angles.



**Figure 5.22: Oleo-Hydraulic cylinders**



**Photo 5.10: Telescopic hydraulic cylinders**

The trashrack should be removable for repair and maintenance and provided with facilities to clean it. To facilitate the hand cleaning of the trashrack it should be inclined at an angle  $300^\circ$  from the horizontal although steeper angles are often used. Trashracks can be cleaned by hand up to 4 meters depth. A horizontal platform above high-water level should be provided to facilitate the operation. On unattended plants operated by remote control, mechanical rakers are used. The mechanical raker can be designed to be operated either on a timed basis or on a head differential basis. The latter uses a sensor to detect the drop in head across the trashrack. An accumulation of trash on the trashrack creates an increased differential head across the trashrack. The raker begins when a predetermined differential head is reached.

The raker in Figure 5.22 is operated through oleo-hydraulic cylinders. The secondary cylinder pushes out or retracts the raker, which rides on a hinged arm. The raker pushes out in its way down to the bottom of the screen and then retracts to travel up along the screen. The raker itself is a series of prongs protruding from a polyamide block that moves along the spaces between the bars. The trash is conveyed to the top to be dumped on a conduit or on to a conveyor. If dumped into a conduit a small water pump delivers enough water to wash the trash along the canal. The problem of trash disposal must be solved case by case, bearing in mind that a trash raker can remove large amount of debris.

When the trashrack is very long the trash raker described above is assembled on a carriage that can move on rails along the intake. Automatic control can be programmed to pass along the supporting structures without human aid. Using telescopic hydraulic cylinders the raker can reach down to 10 m deep, which combined with the almost limitless horizontal movement, makes it possible to clean large surface screens (Photo 5.10).

### 5.5.5 Vorticity

A well-designed intake should not only minimise head losses but also preclude *vorticity*. Vorticity can appear for low-head pressurized intakes (power intakes) and should be avoided because it interferes with the good performance of turbines - especially bulb and pit turbines. Vortices may effectively:

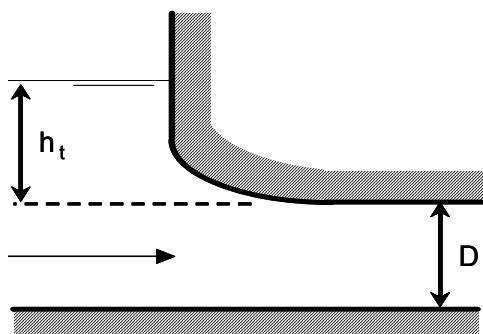
- Produce non-uniform flow conditions
- Introduce air into the flow, with unfavourable results on the turbines: vibration, cavitation, unbalanced loads, etc.
- Increase head losses and decrease efficiency
- Draw trash into the intake

The criteria to avoid vorticity are not well defined, and there is not a single formula that adequately takes into consideration the possible factors affecting it. According to the ASCE Committee on Hydropower Intakes, disturbances, which introduce non-uniform velocity, can initiate vortices. These include:

- Asymmetrical approach conditions
- Inadequate submergence
- Flow separation and eddy formation
- Approach velocities greater than 0.65 m/sec
- Abrupt changes in flow direction

Lack of sufficient submergence and asymmetrical approach seem to be the most common causes of vortex formation. An asymmetric approach is more prone to vortex formation than a symmetrical one. When the inlet to the penstock is deep enough and the flow is undisturbed, vortex formation is unlikely.

Empirical formulas exist that express the minimum degree of submergence of the intake in order to avoid severe vortex formation. Nevertheless, no theory actually exists that fully accounts for all relevant parameters. The minimum degree of submergence is defined as shown in Figure 5.23.



**Figure 5.23: Minimum degree of submergence**

The submersion is defined as  $h_t$ . The following formulas express the minimum values for  $h_t$ :

$$\text{KNAUSS} \quad h_t \geq D \cdot \left( 1 + 2.3 \cdot \frac{V}{\sqrt{g \cdot D}} \right) \quad (5.2)$$

$$\text{NAGARKAR} \quad h_t \geq 4.4 \cdot (V \cdot D^{0.50})^{0.54} \quad (5.3)$$

$$\text{ROHAN} \quad h_t \geq 1.474 \cdot V^{0.48} \cdot D^{0.76} \quad (5.4)$$

$$\text{GORDON} \quad h_t \geq c \cdot V \cdot \sqrt{D} \quad (5.5)$$

with  $c = 0.7245$  for asymmetric approach conditions

$c = 0.5434$  for symmetric approach conditions

It is important to highlight that  $V$  is the velocity inside the downstream conduit in m/s and  $D$  is the hydraulic diameter of the downstream conduit in m.

Beside a minimum submersion, constructive measures might help to prevent vortex formation. For example, asymmetric flow conditions may be prevented by means of vertical walls, piles, screens, floating rafts or by appropriate design of the entrance shape.

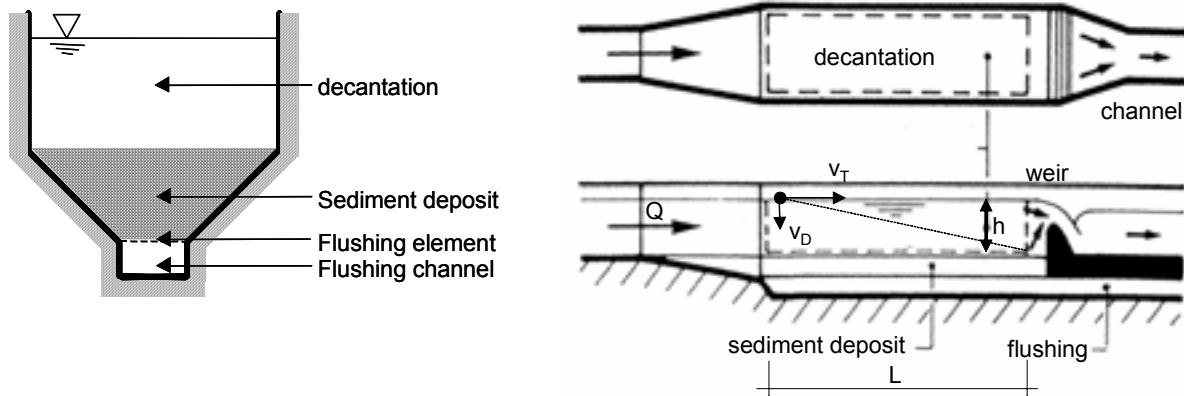
## 5.6 Sediment traps

### 5.6.1 General

Conveyance intakes are designed on rivers in order to eliminate possible floating debris and bedload transport. However, they cannot prevent the entrance of suspended sediment transport. For this, a sediment trap is projected downstream of an intake. The main objective of such a trap is to avoid sedimentation of downstream structures (canals, shafts, etc.) as well as to limit the possible damage of sediments on the hydro mechanical equipment.

A sediment trap is based on the principle of diminishing the flow velocities and turbulence. This results in a decantation of suspended sediments in the trap. This diminishing is obtained by an enlargement of the canal, controlled by a downstream weir as shown in Figure 5.24.





**Figure 5.24: Sediment traps**

A sediment sluicing system that minimises the sluicing time and the wasted water can be used<sup>4</sup>.

5.6.2 Efficiency of a sediment trap

The efficiency of the sediment trap is defined by the grain diameter that deposits in the trap. The choice of efficiency depends on the type of hydro mechanical equipment and on the gross head difference of the power plant. For a Francis turbine, the abrasive power of sediment grains is expressed as a function of the velocity of the grains and the gross head of the plant as follows:

$$P_e = \mu \cdot \nabla \cdot \frac{\rho_s - \rho_E}{R} \cdot V^3 \tag{5.6}$$

in which  $\mu$  is a friction coefficient between the turbine blades and the grains,  $\nabla$  is the volume of the grains,  $\rho_s$  and  $\rho_E$  are the densities of grains and water,  $R$  is the radius of the blades and  $V$  is the grain velocity. The volume of the grains is directly related to the efficiency of the trap.

Reparation intervals of Francis turbines are around 6-7 years for a sediment trap efficiency of 0.2 mm, 3-4 years for an efficiency of 0.3 mm and 1-2 years for an efficiency of only 0.5 mm. It is obvious that the cost of a sediment trap increases with its efficiency. Hence, an optimum efficiency may be found as a function of the construction costs, the energy losses, the reparation costs of the turbines and the exploitation costs. Experience has shown that the most economical solution is around 0.2 mm efficiency for severe conditions (significant gross head, quartz particles) and around 0.3 mm for normal conditions.

5.6.3 Design

The necessary length of a sediment trap is defined by the equipped discharge of the intake and by the chosen efficiency of the trap (grain diameter that still deposits inside the trap). The length has to be such that all grains have the time to deposit before leaving the trap. This happens when the deposition time  $t_D$  equals the transfer time  $t_t$ . The former is defined as  $h/v_D$  and the latter as  $L/v_T$  (see Figure 5.24). Hence, the minimum length required to deposit a grain of diameter  $d_D$  is given:

$$L \geq \frac{Q}{v_D \cdot B} \tag{5.7}$$

The width  $B$  has to stay smaller than  $1/8$  times the length  $L$  and also smaller than twice the flow depth  $h$ . The deposition velocity  $v_D$  is defined by the Newton or Prandtl formula for spherical particles and under ideal conditions, i.e. pure water, no turbulence and no wall effects. It depends on the form drag of the particle, which on its turn depends on the Reynolds number. For real situations, no formula exists and experiments should be carried out. For practice, the empirical formula of Zanke is often used as a first-hand approach in still water flow conditions:

$$v_D = \frac{100}{9 \cdot d} \left( \sqrt{1 + 1.57 \cdot 10^2 \cdot d^3} - 1 \right) \quad (5.8)$$

in which  $v_D$  is expressed in mm/s and the grain diameter  $d$  in mm. This expression is strictly valid for  $T = 20^\circ$  and a grain-to-water density ratio of 2.65.

For turbulent flow conditions, the deposition velocity decreases and the following expression becomes more appropriate:

$$v_D = v_{D0} - \alpha \cdot v_T \geq 0 \quad (5.9)$$

in which  $v_{D0}$  is the deposition velocity in still water and  $\alpha$  a reduction factor (in  $[1/m^{1/2}]$ ) expressed as a function of the trap water depth  $h$  (m):

$$\alpha = \frac{0.132}{\sqrt{h}} \quad (5.10)$$

Finally, for appropriate design, the critical transfer velocity of the trap has to be defined. This critical velocity defines the limit between the suspension regime and the deposition regime. If the velocity is too high, deposited sediments risk to be entrained again by the flow. For a Manning-Strickler roughness value of  $K = 60 \text{ m}^{1/3}/\text{s}$  ( $K = 1/n$ , average value for concrete) and for a grain-to-water density ratio of 2.65 the following formula is valid:

$$v_{cr} = 13 \cdot R_h^{1/6} \cdot \sqrt{d} \quad (5.11)$$

Typical values for  $v_{cr}$  are 0.2-0.3 m/s.

Further information regarding design and construction details can be found for example in Bouvard (1984).

## 5.7 Gates and valves

In every small hydropower scheme some components, for one reason or another (maintenance or repair to avoid the runaway speed on a shutdown turbine, etc) need to be able to be temporarily isolated. Some of the gates and valves suited to the intakes for small hydro systems include the following:

- Stoplogs made up of horizontally placed timbers
- Sliding gates of cast iron, steel, plastic or timber
- Flap gates with or without counterweights
- Globe, rotary, sleeve-type, butterfly and sphere valves

Almost without exception the power intake will incorporate some type of control gate or valve as a guard system located upstream of the turbine and which can be closed to allow the dewatering of the water conduit. This gate must be designed so it can be closed against the maximum turbine flow in case of power failure, and it should be able to be opened partially, under maximum head, to allow the conduit to be filled.

For low pressure the simplest type of gate is a stoplog; timbers placed horizontally and supported at each end in grooves. Stoplogs cannot control the flow and are used only to stop it. If flow must be stopped completely, such as when a repair is needed downstream, the use of two parallel sets of stoplogs is recommended. They should be separated by about 15 cm, so that clay can be packed in between. Gates and valves control the flow through power conduits. Gates of the sliding type are generally used to control the flow through open canals or other low-pressure applications. This is the type of flow control used on conveyance intake structures where, if necessary, the flow can be stopped completely to allow dewatering of the conduit. Cast iron sliding-type gates are those mostly used for openings of less than two square meters. For bigger openings fabricated steel sliding gates are cheaper and more flexible. Gates of the sliding type are seldom used in penstocks because they take too long to close. The stopper slides between two guides inside the gate.

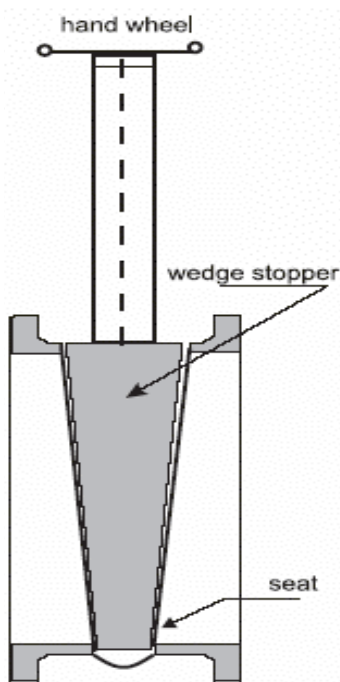


Photo 5.11: wheel-and-axle mechanism

Figure 5.25: Wedge-shaped stopper

When used in a high-pressure conduit the water pressure that forces the stopper against its seat makes the valve difficult to operate. This difficulty is overcome with a wedge-shaped stopper (Figure 5.25), so that the seal is broken over the whole face as soon as it rises even a small distance. To provide a good seal around a sliding gate different kinds of rubber seals are used. They can be made of natural rubber, styrene-butadiene or chloroprene compounds. The seal path is located adjacent to the roller path.

Using a wheel-and-axle mechanism (Photo 5.11), a hydraulic cylinder (Photo 5.12) or an electric actuator on a screw thread can raise small sliding gates controlling the flow.

In butterfly valves a lens shaped disk mounted on a shaft turns to close the gap (Figure 5.26). Under pressure each side of the disk is submitted to the same pressure, so the valve is easy to manoeuvre and closes rapidly. Butterfly valves are used as the guard valves for turbines and as regulating valves. It is easy to understand that when used for regulation their efficiency is rather low because the shaped disk remains in the flow and causes turbulence.



Photo 5.12: Hydraulic Cylinder

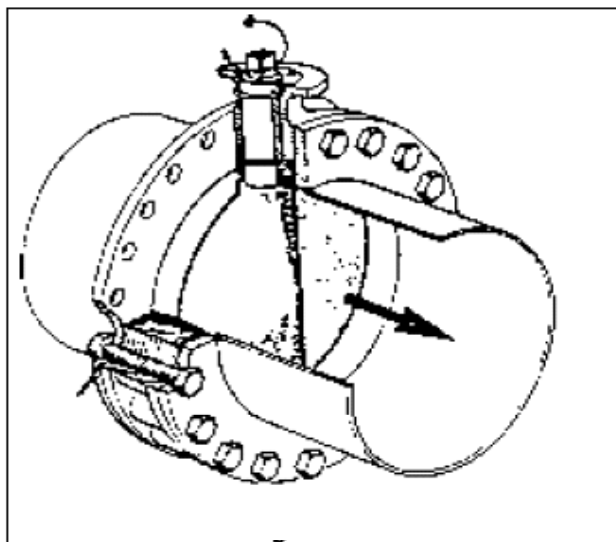


Figure 5.26: Butterfly valves

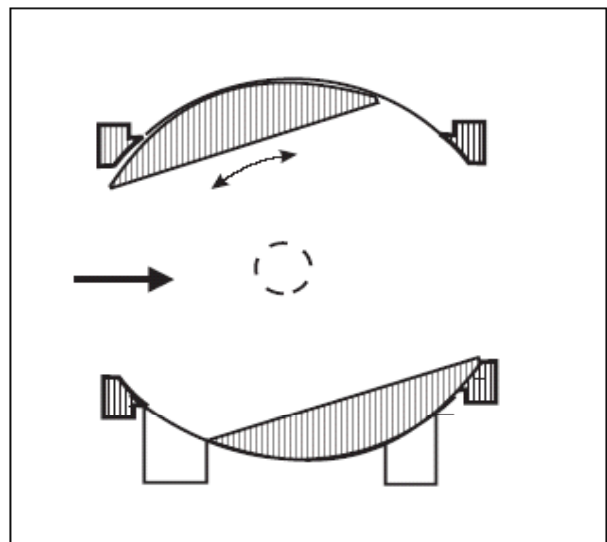
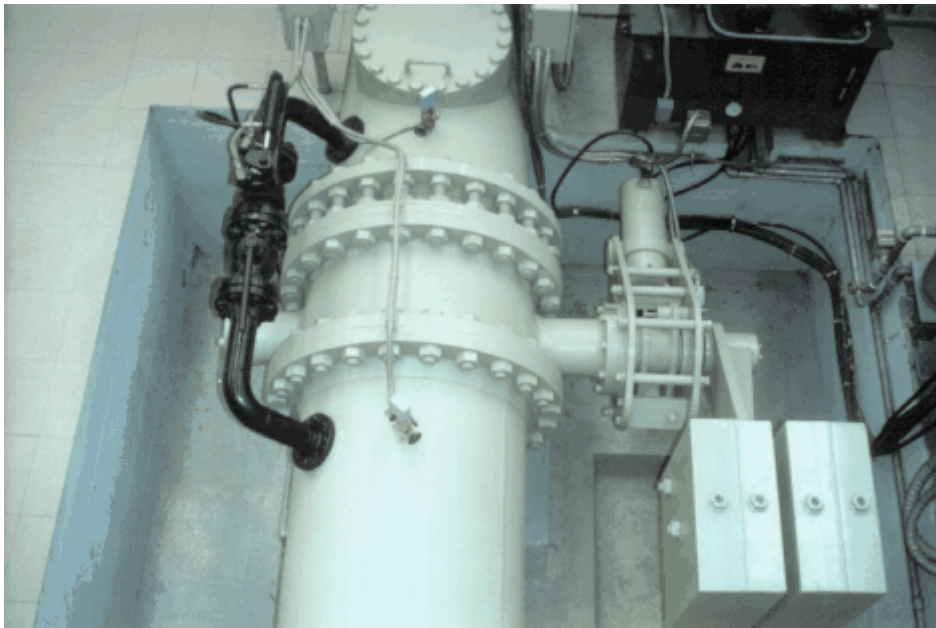


Figure 5.27: Globe and rotary valves

Butterfly valves are simple, rugged and uncomplicated and can be operated manually or hydraulically. Photo 5.13 shows a large butterfly valve being assembled in a powerhouse and Photo 5.14 shows a butterfly valve, hydraulically operated, with an ancillary opening system and a counterweight, at the entrance to a small Francis turbine.



**Photo 5.13: Large butterfly valve**



**Photo 5.14: Butterfly valve hydraulically operated**

Globe and rotary valves (Figure 5.27) have lower head losses than the slide and butterfly gate valves and are also commonly used in spite of their higher price.

The radial gates, conceptually different, are a method of forming a moveable overflow crest and allow a close control of headwater and tailwater. Photo 5.15 shows a Tainter gate at the left, ready to be installed, and the housing of the sector on a concrete pier at the right. The radial gate is operated by raising or lowering to allow water to pass beneath the gate plate. The curved plate that

forms the upstream face is concentric with the trunnions of the gate. The trunnions are anchored in the piers and carry the full hydrostatic load. Because the hydrostatic load passes through the trunnions, the lifting force required by the hoisting mechanism is minimised. The head losses in gates and valves are relatively high, especially when they are operated as regulating devices. For further details refer to Chapter 2, Section 2.2.4 and the enclosed bibliography.



**Photo 5.15: Tainter gate (left) and housing of its sector on a concrete pier**

## 5.8 Open channels

### 5.8.1 Design and dimensioning

The flow conveyed by a canal is a function of its cross-sectional profile, its slope, and its roughness. Natural channels are normally very irregular in shape, and their surface roughness changes with distance and time. The application of hydraulic theory to natural channels is more complex than for artificial channels where the cross-section is regular in shape and the surface roughness of the construction materials - earth, concrete, steel or wood - is well documented, so that the application of hydraulic theories yields reasonably accurate results.

Table 2.4, Chapter 2, illustrates the fundamental geometric properties of different channel sections.

In small hydropower schemes the flow in the channels is in general in the rough turbulent zone and the Manning equation can be applied:

$$Q = \frac{A \cdot R^{2/3} \cdot S^{1/2}}{n} = \frac{A^{5/3} \cdot S^{1/2}}{n \cdot P^{2/3}} \tag{5.12}$$

where n is Manning's coefficient, which in the case of artificial lined channels may be estimated with reasonable accuracy, and S is the hydraulic gradient, which normally is the bed slope. Alternatively:

$$S = \left( \frac{Q \cdot n \cdot P^{2/3}}{A^{5/3}} \right)^2 = \left( \frac{Q \cdot n}{AR^{2/3}} \right)^2 \tag{5.13}$$

The above equation applies when metric or SI units are used. To use Imperial or English units the equation must be modified to:

$$Q = \frac{1.49 A^{5/3} \cdot S^{1/2}}{n \cdot P^{2/3}} \tag{5.14}$$

where Q is in ft<sup>3</sup>/s; A in ft<sup>2</sup> and P in ft. n has the same value as before.

The above equation shows that for the same cross-sectional area A and channel slope S, the channel with a larger hydraulic radius R, delivers a larger discharge. That means that for a given cross-sectional area, the section with the least wetted perimeter is the most efficient hydraulically. Semicircular sections are consequently the most efficient. A semicircular section however, unless built with prefabricated materials, is expensive to build and difficult to maintain. The most efficient trapezoidal section is the half hexagon, whose side slope is 1 vertical to 0.577 horizontal. Strictly, this is only true if the water level reaches the level of the top of the bank. Actual dimensions have to include a certain freeboard (vertical distance between the designed water surface and the top of the channel bank) to prevent water level fluctuations overspilling the banks. Minimum freeboard for lined canals is about 10 cm, and for unlined canals this should be about one third of the designed water depth with a minimum of fifteen centimetres. One way to prevent overflow of the canal is to provide spillways at appropriate intervals; any excess water is conveyed, via the spillway, to an existing streambed or to a gully.

**Table 5.2: Hydraulic parameters for common canal cross-sections**

Type of Channel	Manning's n
<b>Excavated earth channels</b>	
Clean	0.022
Gravelly	0.025
Weedy	0.030
Stony, cobbles (or natural streams)	0.035
<b>Artificially lined channels</b>	
Brass	0.011
Steel, smooth	0.012
Steel, painted	0.014
Steel, riveted	0.015
Cast iron	0.013
Concrete, well-finished	0.012
Concrete, unfinished	0.014
Planed wood	0.012
Clay tile	0.014
Brickwork	0.015
Asphalt	0.016
Corrugated metal	0.022
Rubble masonry	0.025

It should be noted that the best hydraulic section does not necessarily have the lowest excavation cost. If the canal is unlined, the maximum side slope is set by the slope at which the material will permanently stand under water. Clay slopes may stand at 1 vertical to 3/4 horizontal, whereas sandy soils must have flatter slopes (1 to 2).

Table 5.3 defines for the most common canal sections the optimum profile as a function of the water depth y, together with the parameters identifying the profile.

**Table 5.3: Optimum profile for different channel sections**

Channel section	Area A	Wetted perimeter P	Hydraulic radius R	Top width T	Water depth d
Trapezoid: half hexagon	$1.73 y^2$	$3.46 y$	$0.500 y$	$2.31 y$	$0.750y$
Rectangle : half square	$2 y^2$	$4 y$	$0.500 y$	$2 y$	$y$
Triangle: half square	$y^2$	$2.83 y$	$0.354 y$	$2 y$	$0.500y$
Semicircle	$0.5\pi y^2$	$\pi y$	$0.500 y$	$2 y$	$0.250\pi y$

*Example 5.1*

Assuming a flow depth of 1 m, a channel base width of 1.5 m and side slopes of 2 vertical to 1 horizontal, a bed slope of 0.001 and a Manning's coefficient of 0.015, determine the discharge (Q), the mean velocity (V).

According to Table 2.4 for b=1.5, x=1/2 and y=1

$$A=(1.5+0.5x1)x1=2m^2; P = 1.5 + 2x\sqrt{1 + 0.5^2} = 3.736m$$

Applying 5.6) for A=2 and P=3.736

$$Q = \frac{1}{0.015} x \frac{2^{5/3}}{3.736^{2/3}} x \sqrt{0.001} = 2.78m^3 / s$$

$$V=Q/A=2.78/2=1.39 m/s$$

*Example 5.2*

Determine the slope knowing the discharge and the canal dimensions. Assuming a canal paved with smooth cement surface (n=0.011), a channel base of 2 m, side slopes with inclination 1v:2h and a uniform water depth of 1.2 m, determine the bed slope for a discharge of 17.5 m<sup>3</sup>/s.

Applying the formulae of table 2.4:



$$S = \left( \frac{17.5 \cdot 0.011}{5.28 \cdot 0.717^{2/3}} \right)^2 = 0.002$$

When the canal section, the slope and discharge are known and the depth "d" is required, equation 5.6 - nor any other - does not provide a direct answer, so iterative calculations must be used.

### Example 5.3

A trapezoidal open channel has a bottom width of 3 m and side slopes with inclination 1.5:1. The channel is lined with unfinished concrete. The channel is laid on a slope of 0.0016 and the discharge is 21 m<sup>3</sup>/s. Calculate the depth.

According to 5.6 the section factor:

$$A=(b+zy)y = (3 + 1.5y)y \quad P=b+2y(1+z^2)^{0.5} = 3+3.6y$$

Compute the factor section for different values of y, up to find one approaching closely 6.825:

For y = 1.5 m A=7.875, R=0.937, AR<sup>2/3</sup>=7.539

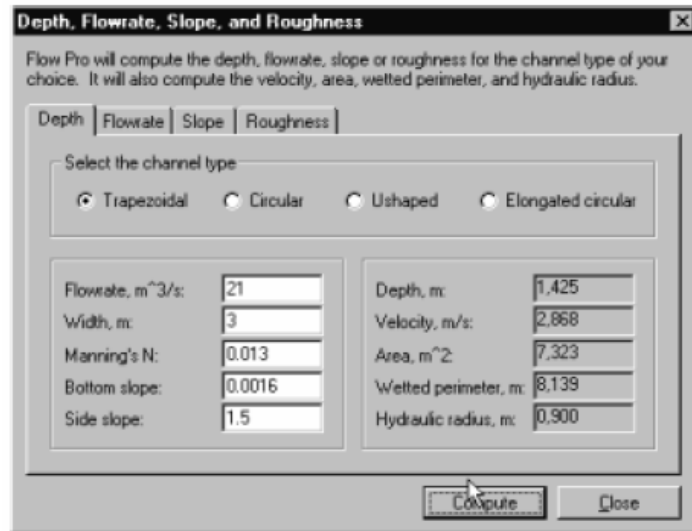
For y = 1.4 m A=7.140, R=0.887. AR<sup>2/3</sup>=6.593

For y = 1.43 m A=7.357, R=0.902, AR<sup>2/3</sup>=6.869

According to the above results the normal depth is slightly under 1.43. Using the software program FlowPro, mentioned in Chapter 2 it would be instantaneously calculated, as shown in the enclosed captured screen: a depth of 1.425, with A=2.868, P=8.139, R=0.900 and a section factor 6.826

Summarising, the design of fabricated channels is a simple process requiring the following steps:

- Estimate the coefficient n from table 5.2
- Compute the form factor  $AR^{2/3}=nQ/S^{1/2}$  with the known parameters in second term
- If optimum section is required apply values in table 5.3. Otherwise use values in table 2.4
- Check if the velocity is high enough to form deposit or aquatic flora
- Check the Froude number NF to determine if it is a subcritical or a supercritical flow
- Define the required freeboard



Example 5.4

Design a trapezoidal channel for an 11 m<sup>3</sup>/s discharge. The channel will be lined with well-finished concrete and the slope 0.001.

Step 1. Manning n = 0.012

Step 2. Compute form factor

$$AR^{2/3} = \frac{nQ}{\sqrt{S}} = \frac{0.012 \times 11}{\sqrt{0.001}} = 4.174$$

Step 3. Not intended to find the optimum section.

Step 4. Assuming a bottom width of 6 m and side slopes with inclination 2:1 compute the depth d by iteration as in example 5.3.

$$d = 0.87 \text{ m} \quad A = 6.734 \text{ m}^2$$

Step 5. Compute the velocity

$$V = 11/6.734 = 1.63 \text{ m/s} \quad \text{OK}$$

Step 6. Total channel height. The tables of the US Bureau of Reclamation (USA) recommend a freeboard of 0.37 m. The FlowPro software would provide all these results.

5.8.2 Excavation and stability

In conventional hydropower schemes and in some of the small ones, especially those located in wide valleys where the channels must transport large discharges, the channels are designed in the manner shown in Figure 5.28. According to this profile, the excavated ground is used to build the embankments, not only up to the designed height but to provide the freeboard, the extra height necessary to account for the height increase produced by a sudden gate closing, waves or the excess

arising in the canal itself under heavy storms. These embankment channels although easy to construct are difficult to maintain, due to wall erosion and aquatic plant growth.

The stability of the walls is defined by the eventual sliding of the material. This sliding can be enhanced by rapid water level changes in the canal. The velocity of water in unlined canals should be kept above a minimum value to prevent sedimentation and aquatic plant growth, but below a maximum value to prevent erosion.

If the canal is unlined, the maximum velocity to prevent erosion is dependent on the mean grain diameter of the bank material  $d_m$ :

$$V \leq 5.7 \cdot d_m^{1/3} \cdot R_h^{1/6} \tag{5.15}$$

Where  $R_h$  stands for the hydraulic radius of the canal. For grain diameters of 1 mm and hydraulic radius of 1 to 3 m, critical velocities of 0.6-0.7 m/s are obtained. For grain diameters of 10 mm, the critical velocities are between 1.2 and 1.5 m/s for the same hydraulic radius. The above equation can be used for grain diameters larger than 0.1 mm.

For cohesive soils, the critical velocities are between 0.4 and 1.5 m/s. Concrete-lined canals may have clear water velocities up to 10 m/s without danger. Even if the water contains sand, gravel or stones, velocities up to 4 m/s are acceptable.

On the other hand, to keep silt in suspension after the intake, the flow velocity should be at least 0.3-0.5 m/s. To prevent aquatic plant growth, the minimum velocities are 0.5-0.75 m/s and the minimum water depths are 1.5 to 2.0 m.

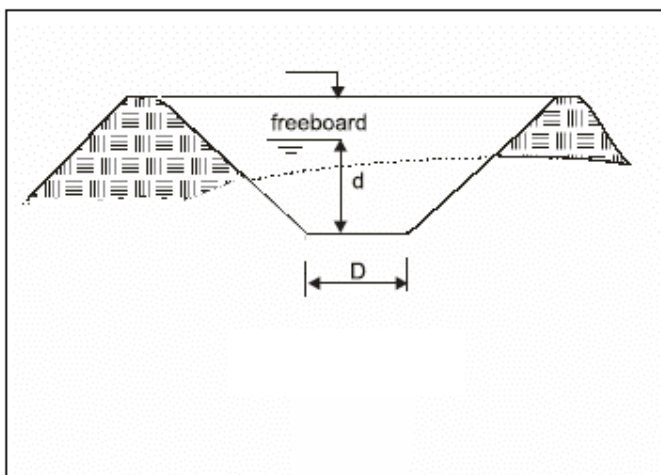


Figure 5.28: Channel design

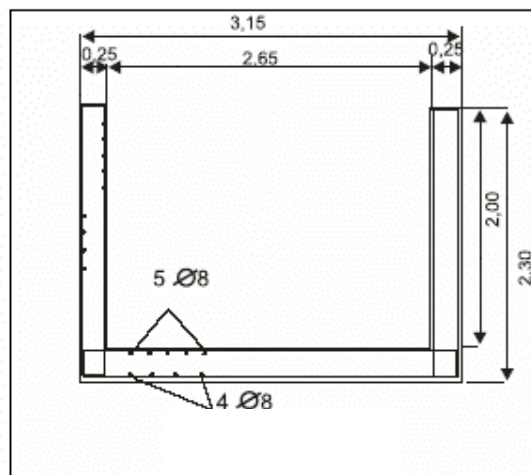
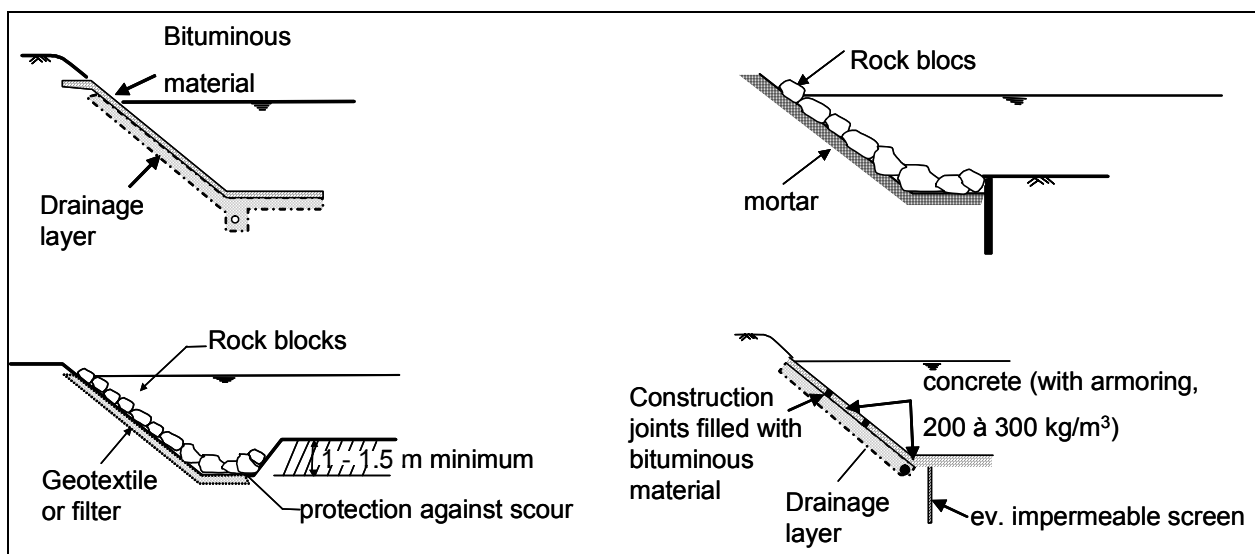


Figure 5.29: Rectangular reinforced canal

An appropriate lining provides bank protection. Possible materials to be used for protection are vegetation, rock blocks with or without mortar, bituminous material, or concrete. Some examples are presented in Figure 5.30.



**Figure 5.30: Materials used for protection**

In high mountain schemes the canal is usually built from reinforced concrete, so that environmental legislation may require it to be covered and revegetated. Figure 5.29 shows the schematic section of a rectangular reinforced concrete canal in the Cordinañes scheme, referred to in Chapter 4 and Photo 5.15 shows the same canal not yet covered with the concrete slab that would serve as a basis for new ground and new vegetation. Sometimes, to ensure that no seepage will occur, the canal is lined with geotextile sheets, to prevent landslides consequent to the wetting of clayey material.

As is shown in the following examples, once the canal profile has been selected it is easy to compute its maximum discharge.



**Photo 5.15: Canal in the Cordinañes**



**Photo 5.16: Lateral spillway**

To ensure that the channel never overflows, endangering the slope stability, and in addition to provide a generous freeboard, a lateral spillway (as in Photo 5.16) should be provided.

Before definitely deciding on the channel route, a geologist should carefully study the geomorphology of the terrain. Photo 5.17 shows clearly how uplift can easily ruin a power channel (6 m wide and 500 m long, in a 2 MW scheme). On one particular day, a flood occurred which was later calculated to be a 100 year event. At the time the flood occurred, the headrace channel had been empty, and uplift pressures destroyed the channel. Consideration should also be taken of the type of accidents detailed in Chapter 4, section 4.4.



**Photo 5.17: Uplift**



**Photo 5.18: Flume**

### Circumventing obstacles

Along the alignment of a canal obstacles may be encountered, and to bypass them it will be necessary to go over, around or under them.

The crossing of a stream or a ravine requires the provision of a flume, a kind of prolongation of the canal, with the same slope, supported on concrete or steel piles or spanning as a bridge. Steel pipes are often the best solution, because a pipe may be used as the chord of a truss, fabricated in the field. The only potential problem is the difficulty of removing sediment deposited when the canal is full of still water. Photo 5.18 shows a flume of this type in China.

Inverted siphons can also solve the problem. An inverted siphon consists of an inlet and an outlet structure connected by a pipe. The diameter calculation follows the same rules as for penstocks, which are analysed later.

## 5.9 Penstocks

### Arrangement and material selection for penstocks

Conveying water from the intake to the powerhouse (this is the purpose of a penstock) may not appear a difficult task. However deciding the most economical arrangement for a penstock is not so simple. Penstocks can be installed over or under the ground, depending on factors such as the nature of the ground itself, the penstock material, the ambient temperatures and the environmental requirements.

A flexible and small diameter PVC penstock for instance, can be laid on the ground, following its outline with sand and gravel surrounding the pipe to provide good insulation. Small pipes installed in this way do not need anchor blocks and expansion joints.

Larger penstocks are usually buried, as long as there is only a minimum of rock excavation required. Buried penstocks must be carefully painted and wrapped to protect the exterior from corrosion, but provided the protective coating is not damaged when installed, further maintenance should be minimal. From the environmental point of view the solution is optimal because the ground can be returned to its original condition, and the penstock does not constitute a barrier to the movement of wildlife.

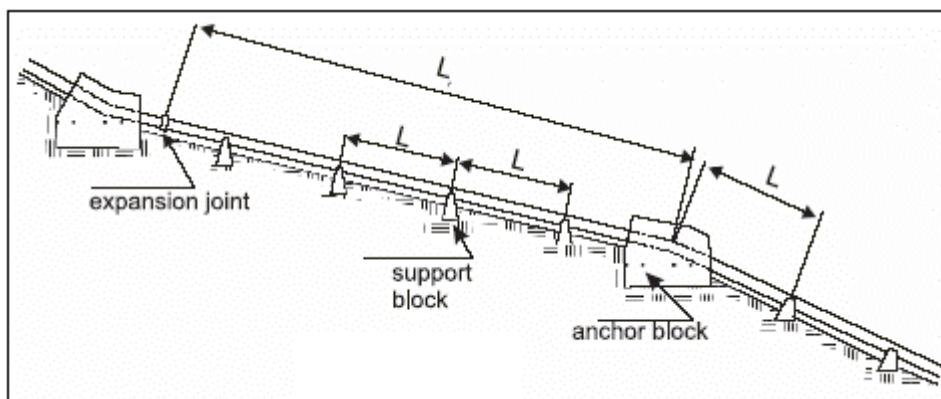


Figure 5.31: Penstock

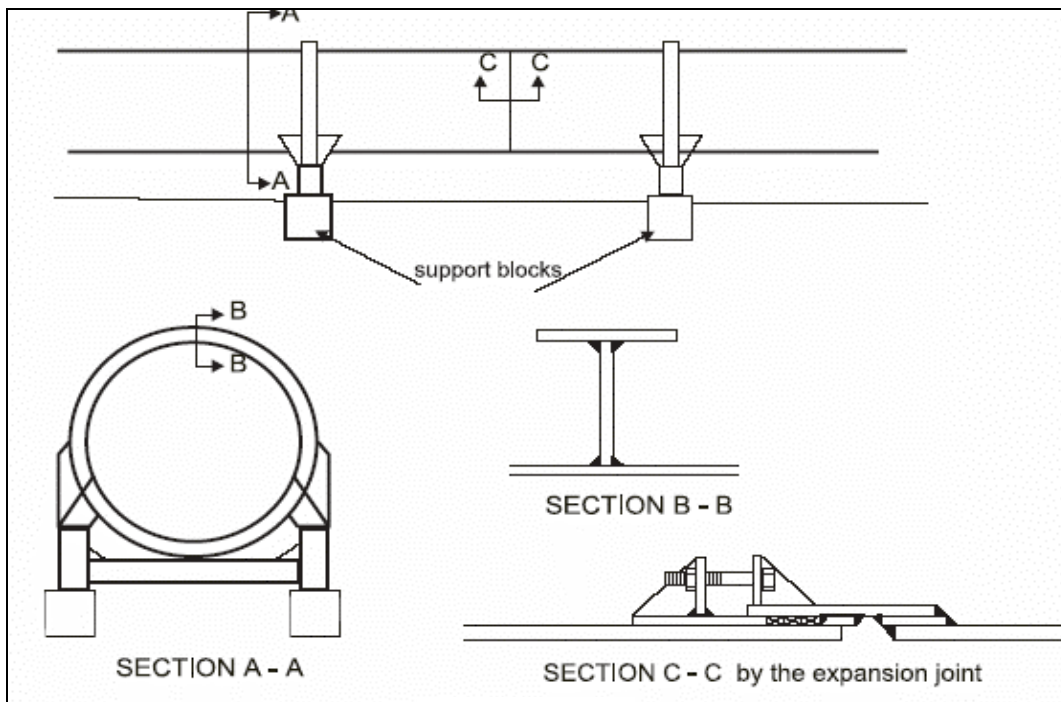
A penstock installed above ground can be designed with or without expansion joints. Variations in temperature are especially important if the turbine does not function continuously, or when the penstock is dewatered for repair, resulting in thermal expansion or contraction. Usually the penstock is built in straight or nearly straight lines, with concrete anchor blocks at each bend and with an expansion joint between each set of anchors (Figure 5.31). The anchor blocks must resist the thrust of the penstock plus the frictional forces caused by its expansion and contraction, so when possible they should be founded on rock. If, due to the nature of the ground, the anchor blocks require large volumes of concrete, thus becoming rather expensive, an alternative solution is to eliminate every second anchor block and all the expansion joints, leaving the bends free to move slightly. In this case it is desirable to lay the straight sections of the penstock in steel saddles, made to fit the contour of the pipe and generally covering 120 degrees of the invert (Figure 5.32). The saddles can be made from steel plates and shapes, with graphite asbestos sheet packing placed between saddle and pipe to reduce friction forces. The movement can be accommodated with expansion joints, or by designing the pipe layout with bends free to move.

If a pipeline system using spigot and socket joints with O-ring gaskets is chosen, then expansion and contraction is accommodated in the joints.

Today there is a wide choice of materials for penstocks. For the larger heads and diameters, fabricated welded steel is probably the best option. Nevertheless spiral machine-welded steel pipes should be considered, due to their lower price, if they are available in the required sizes. For high heads, steel or ductile iron pipes are preferred, but at medium and low heads steel becomes less competitive, because the internal and external corrosion protection layers do not decrease with the wall thickness and because there is a minimum wall thickness for the pipe.

For smaller diameters, there is a choice between: manufactured steel pipe, supplied with spigot and socket joints and rubber "O" gaskets, which eliminates field welding, or with welded-on flanges, bolted on site (Figure 5.33); plain spun or pre-stressed concrete; ductile iron spigot and socket pipes with gaskets; cement-asbestos; glass-reinforced plastic (GRP); and PVC or polyethylene (PE) plastic pipes. Plastic pipe PE14 is a very attractive solution for medium heads (a PVC pipe of 0.4 m diameter can be used up to a maximum head of 200 meters) because it is often cheaper, lighter and more easily handled than steel and does not need protection against corrosion. PVC15 pipes are easy to install because of the spigot and socket joints provided with "O" ring gaskets. PVC pipes are usually installed underground with a minimum cover of one metre. Due to their low resistance to UV radiation they cannot be used on the surface unless painted, coated or wrapped. The minimum radius of curvature of a PVC pipe is relatively large (100 times the pipe diameter)– and its coefficient of thermal expansion is five times higher than that for steel. They are also rather brittle and unsuited to rocky ground.

Pipes of PE16 – (high molecular weight polyethylene) can be laid on top of the ground and can accommodate bends of 20-40 times the pipe diameter (for sharper bends, special factory fittings are required). PE pipe floats on water and can be dragged by cable in long sections but must be joined in the field by fusion welding, requiring a special machine. PE pipes can withstand pipeline freeze-up without damage, may be not available in sizes over 300 mm diameter.



**Figure 5.32: Penstock with concrete anchor blocks and expansion joints**

Concrete penstocks, both pre-stressed with high tensile wires or steel reinforced, featuring an interior steel jacket to prevent leaks, and furnished with rubber gasket spigot and socket joints constitute another solution. Unfortunately their heavy weight makes transportation and handling costly, but they are not affected by corrosion.

In developing countries, pressure creosoted wood-stave, steel-banded pipe is an alternative that can be used in diameters up to 5.5 metres and heads of up to 50 metres (which may be increased up to 120 meters for a diameter of 1.5 metres). The advantages include flexibility to conform to ground settlement, ease of laying on the ground with almost no grade preparation, no requirement for expansion joints and no necessity for concrete supports or corrosion protection. Wood-stave pipe is assembled from individual staves and steel bands or hoops that allow it to be easily transported even over difficult terrain. Disadvantages include leakage, particularly in the filling operations, the need to keep the pipe full of water when repairing the turbine, and considerable maintenance such as spray coating with tar every five years. Table 5.3 shows the main properties of the above material. Some of these properties are not always typical, particularly the values of the Hazen Williams coefficient which depends on the surface condition of the pipe.



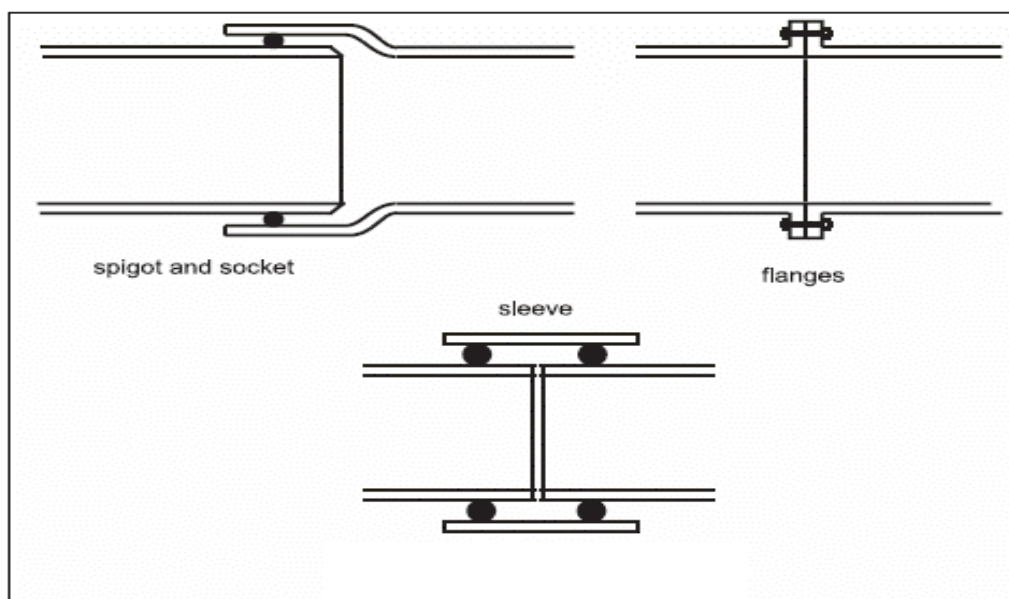


Figure 5.33: Manufactured steel pipe

Table 5.4: Different material’s characteristics

Material	Young's modulus of elasticity E(N/m <sup>2</sup> )E9	Coefficient of linear expansion a (m/m °c)E6	Ultimate tensile strength (N/m <sup>2</sup> )E6	n
Welded Steel	206	12	400	0.012
Polyethylene	0.55	140	5	0.009
Polyvinyl Chloride (PVC)	2.75	54	13	0.009
Asbestos Cement	n/a	8.1	n/a	0.011
Cast iron	78.5	10	140	0.014
Ductile iron	16.7	11	340	0.013

**Hydraulic design and structural requirements**

A penstock is characterised by materials, diameter, wall thickness and type of joint:

- the material is selected according to the ground conditions, accessibility, weight, jointing system and cost,
- the diameter is selected to reduce frictional losses within the penstock to an acceptable level,

- the wall thickness is selected to resist the maximum internal hydraulic pressure, including transient surge pressure that will occur.

*Penstock diameter*

The diameter is selected as the result of a trade-off between penstock cost and power losses. The power available from the flow Q and head H is given by the equation:

$$P=QH\gamma\eta$$

where Q is the discharge in m<sup>3</sup>/s, H the net head in m, γ the specific weight of water in kN/m<sup>3</sup> and η the overall efficiency.

The net head equals the gross head minus the sum of all losses, including the friction and turbulence losses in the penstock, that are approximately proportional to the square of the velocity of the water in the pipe. To convey a certain flow, a small diameter penstock will need a higher water velocity than a larger diameter penstock, and therefore the losses will be greater. Selecting a diameter as small as possible will minimise the penstock cost but the energy losses will be larger and vice versa. Chapter 2 details the friction loss calculations, putting special emphasis on the graphic representation of the Colebrook equations (the Moody diagram and the Wallingford charts) and on the Manning's formula. In this chapter the above principles are used and some examples will facilitate their application in real cases.

A simple criterion for diameter selection is to limit the head loss to a certain percentage. Loss in power of 4% is usually acceptable. A more rigorous approach is to select several possible diameters, computing power and annual energy. The present value of this energy loss over the life of the plant is calculated and plotted for each diameter (Figure 5.34). On the other side the cost of the pipe for each diameter is also calculated and plotted. Both curves are added graphically and the optimum diameter would be that closest to the theoretical optimum.

Actually the main head loss in a pressure pipe are friction losses. The head losses due to turbulence passing through the trashrack, in the entrance to the pipe, in bends, expansions, contractions and valves are minor losses. Consequently a first approach will suffice to compute the friction losses, using for example the Manning equation:

$$\frac{h_f}{L} = 10.3 \frac{n^2 Q^2}{D^{5.333}} \tag{5.16}$$

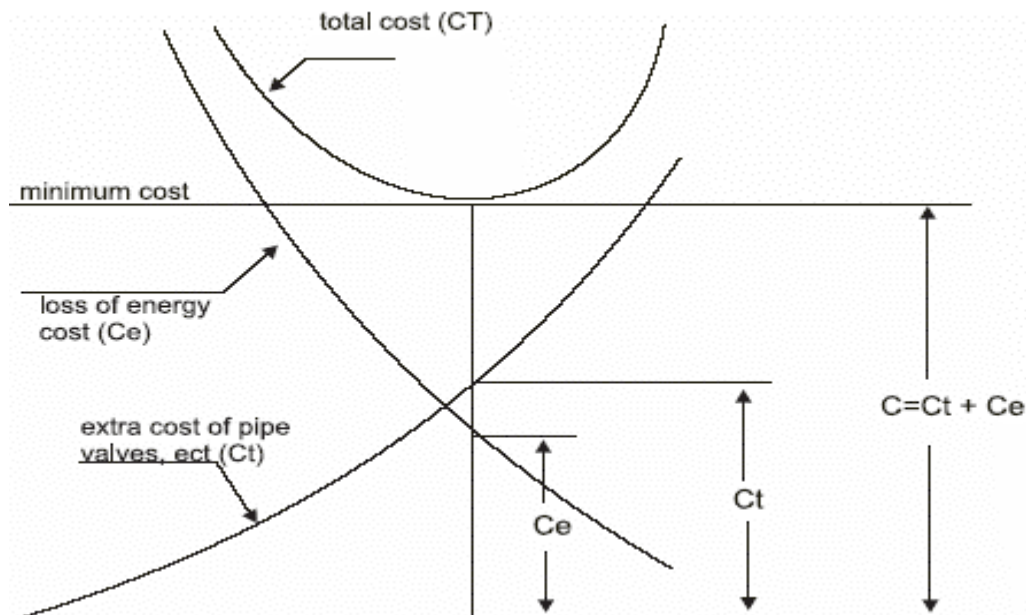
Examining the above equation, it can be seen that dividing the diameter by two would lead to the losses being multiplied by 40.

From this it follows that:

$$D = \left( \frac{10.3 \cdot n^2 Q^2 \cdot L}{h_f} \right)^{0.1875} \tag{5.17}$$

If we limit h<sub>f</sub> at 4H/100, D can be computed knowing Q, n and L, by the equation:

$$D = 2.69 \left( \frac{n^2 Q^2 L}{H} \right)^{0.1875} \tag{5.18}$$



**Figure 5.34: Energy loss**

*Example 5.5*

A scheme has a gross head of 85 m, a discharge of 3 m<sup>3</sup>/s, and a 173 m long penstock in welded steel. Calculate the diameter so the power losses due to friction do not surpass 4%.

According to equation (5.18):

$$D = 2.69 \left( \frac{3^2 \times 0.012^2 \times 173}{85} \right)^{0.1875} = 0.88 \text{ m}$$

We select a 1m steel welded pipe and compute all the losses in the next example

*Example 5.6*

Compute the friction and turbulence head losses in a scheme as that illustrated in Figure 5.35. The rated discharge is 3 m<sup>3</sup>/s and the gross head 85 m. The steel welded penstock diameter 1.0 m. The radius of curvature of the bends is four times the diameter. At the entrance of the power intake there is a trashrack with a total surface of 6 m<sup>2</sup>, inclined 60° to the horizontal. The bars are 12-mm thick stainless steel bars, and the distance between bars is 70 mm.

The flow velocity approaching the screen is: (with K1=1)

$$V_0 = 3 \times \frac{70+12}{70} \times \frac{1}{6} \times \frac{1}{0.866} = 0.7 \text{ m/s}$$

The head loss through the trashrack is given by the Kilchner formula:

$$h_f = 2.4 \times \left(\frac{12}{70}\right)^{4/3} \times \frac{0,7^2}{2 \times 9.81} \times 0.866 = 0.0049 \text{ m}$$

The head loss at the inlet of the penstock is given in Figure 2.11, Chapter 2: K=0.08. The velocity in the penstock is 3.82 m/s, so the head loss at the inlet:

$$h_e = 0.08 \times 3.822 / (2 \times 9.81) = 0.06 \text{ m}$$

The gross head at the beginning of the penstock is therefore

$$85 - 0.005 - 0.06 = 84.935 \text{ m}$$

The friction loss in the penstock, according Manning equation (2.15) is:

$$h_f = \frac{10.3 \times 0.012^2 \times 3^2}{1.0^{5.333}} \times 173 = 2.30 \text{ m}$$

The Kb coefficient for the first bend is 0.05. The coefficient for the second bend Kb=0.085 and for the third bend Kb=0.12. The head losses in the three bends amount to:

$$(0.05 + 0.085 + 0.12) \times 3.822 / (2 \times 9.81) = 0.19 \text{ m.}$$

$$\text{The head loss in the gate valve } 0.15 \times 3.822 / (2 \times 9.81) = 0.11 \text{ m}$$

Summarising: head loss in trashrack plus pipe inlet: 0.065

head loss in three bends and valve : 0.30 m

head loss by friction in the penstock: 2.30 m

Total head loss: 2.665 m equivalent to 3.14% of the gross power.

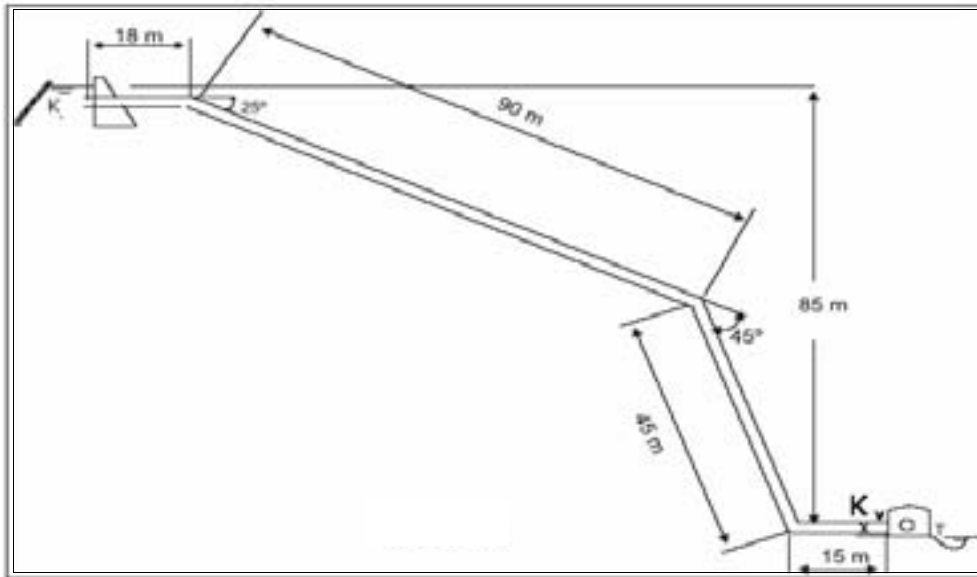


Figure 5.35: Friction and turbulence head losses

Wall thickness

The wall thickness required depends on the pipe material, its ultimate tensile strength (and yield), the pipe diameter and the operating pressure. In steady flows (discharge is assumed to remain constant with time) the operating pressure at any point along a penstock is equivalent to the head of water above that point. The wall thickness in this case is computed by the equation:

$$e = \frac{P_1 \cdot D}{2\sigma_f} \tag{5.19}$$

where

e = Wall thickness in mm

P<sub>1</sub> = Hydrostatic pressure in kN/mm<sup>2</sup>

D = Internal pipe diameter in mm

σ<sub>f</sub> = Allowable tensile strength in kN/mm<sup>2</sup>

In steel pipes the above equation is modified by:

$$e = \frac{P_1 \cdot D}{2\sigma_f \cdot k_f} + e_s$$

where

e<sub>s</sub> = extra thickness to allow for corrosion

$k_f$  = weld efficiency

$k_f$  = 1 for seamless pipes

$k_f$  = 0.9 for x-ray inspected welds

$k_f$  = 1.0 for x-ray inspected welds and stress relieved

$\sigma_f$  = allowable tensile stress (1400 kN/mm<sup>2</sup>)

The pipe should be rigid enough to be handled without danger of deformation in the field. ASME recommends a minimum thickness in mm equivalent to 2.5 times the diameter in metres plus 1.2 mm. Other organisations recommend as minimum thickness  $t_{min}=(D+508)/400$ , where all dimensions are in mm.

In high head schemes it can be convenient to use penstock of uniform diameter, but with different thickness as a function of the hydrostatic pressures.

A certain area of the penstock can remain under the Energy Gradient Line and collapse by sub-atmospheric pressure. The collapsing depression will be given by:

$$P_c = 882500x\left(\frac{e}{D}\right)^3 \tag{5.20}$$

where e and D are respectively the wall thickness and diameter of the pipe in mm.

This negative pressure can be avoided by installing an aeration pipe with a diameter in cm given by:

$$d = 7.47 \sqrt{\frac{Q}{\sqrt{P_c}}} \tag{5.21}$$

provided  $P_c \leq 0.49 \text{ kgN/mm}^2$  ; otherwise  $d=8.94 \sqrt{Q}$  .

Sudden changes of flow can occur when the plant operator or the governing system opens or closes the gates rapidly. Occasionally the flow may even be stopped suddenly due to full load rejection, or simply because an obstruction becomes lodged in the nozzle of a Pelton turbine jet. A sudden change of flow rate in a penstock may involve a great mass of water moving inside the penstock. The pressure wave which occurs with a sudden change in the water's velocity is known as water hammer; and although transitory, can cause dangerously high and low pressures whose effects can be dramatic: the penstock can burst from overpressure or collapse if the pressures are reduced below ambient. The surge pressures induced by the water hammer phenomenon can be of a magnitude several times greater than the static pressure due to the head, and must be considered in calculating the wall thickness of the penstock.

Detailed information on the water hammer phenomenon can be found in texts on hydraulics, and information is given in Chapter 2, section 2.2.3. Some examples will show the application of the recommended formulae.

As explained in Chapter 2, the pressure wave speed c (m/s) depends on the elasticity of the water and pipe material according to the formula:

$$c = \sqrt{\frac{10^{-3} k}{\left(1 + \frac{kD}{Et}\right) \rho}} \quad (5.22)$$

where

k = bulk modulus of water  $2.1 \times 10^9 \text{ N/m}^2$

E = modulus of elasticity of pipe material ( $\text{N/m}^2$ )

t = wall thickness (mm)

The time taken for the pressure wave to reach the valve on its return, after sudden closure is known as the critical time:

$$T = 2L/c \quad (5.23)$$

For instantaneous closure (the pressure wave reaches the valve after its closure) the increase in pressure, in metres of water column, due to the pressure wave is:

$$P = c \frac{\Delta_v}{g} \quad (5.24)$$

where  $\Delta_v$  is the velocity change.

Examples 6.4 and 6.5 shows that surge pressures in steel pipes are more than three times greater than in PVC, due to the greater stiffness of the steel.

*Example 5.7*

Calculate the pressure wave velocity, for instant closure, in a steel penstock 400mm diameter and 4mm-wall thickness.

Applying the above equations gives:

$$c = \sqrt{\frac{2.1 \times 10^6}{1 + \frac{2.1 \times 10^9 \times 400}{2.1 \times 10^{11} \times 4}}} = 1024 \text{ m/s}$$

b) The same for a PVC pipe 400 mm diameter and 14 mm wall thickness.

$$c = \sqrt{\frac{2.1 \times 10^6}{1 + \frac{2.1 \times 10^9 \times 400}{2.75 \times 10^9 \times 14}}} = 305 \text{ m/s}$$

Example 5.8

What is the surge pressure, in the case of instant valve closure, in the two penstocks of example 5.7, if the initial flow velocity is 1.6 m/s?

a) steel penstock:

$$P_s = \frac{1024 \times 4}{9.8} = 417 \text{ m}$$

b) PVC penstock:

$$P_s = \frac{30^5 \times 4}{9.8} = 123 \text{ m}$$

As the example 5.8 shows, the surge pressure in the steel pipe is three times higher than in the PVC pipe, due to the greater rigidity of the steel.

If the change in velocity occurs in more than ten times the critical time T, little or no overpressure will be generated and the phenomenon may be ignored. In between, if  $T > 2L/c$ ,  $P_s$  will not develop fully, because the reflected negative wave arriving at the valve will compensate for the pressure rise. In these cases the Allievi formula may compute the maximum overpressure:

$$\Delta P = P_o \left( \frac{N}{2} \pm \sqrt{\frac{N^2}{4} + N} \right) \tag{5.25}$$

where  $P_o$  is the hydrostatic pressure due to the head and:

$$N = \left( \frac{LV_0}{gP_0t} \right)^2 \tag{5.26}$$

where:

$V_0$  = water velocity in m/s

L = total penstock length (m)

$P_0$  = gross hydrostatic pressure (m)

t = closing time (s)

The total pressure experienced by the penstock is  $P = P_0 + \Delta P$

The next example illustrates the application of the Allievi formula, when the closure time is at least twice but less than 10 times the critical time.



Example 5.9

Calculate the wall thickness in the penstock analysed in example 5.6 if the valve closure time is 3 seconds.

Summarising the data,

Gross head: 84.935 m

Rated discharge: 3 m<sup>3</sup>/s

Internal pipe diameter 1.0 m

Total pipe length: 173 m

Estimating in a first approach at 5 mm wall thickness to compute the wave speed c:

$$c = \sqrt{\frac{2.1 \times 10^6}{1 + \frac{2.1 \times 10^9 \times 1000}{2.1 \times 10^{11} \times 5}}} = 836.7 \text{ m/s}$$

The closure time is bigger than the critical one (0.41 s) but smaller than 10 times its value, so the Allievi formula can be applied.

The water velocity in the pipe is:

$$V = \frac{4 \times 3}{\pi \times 1.0^2} = 3.82 \text{ m/s}$$

N would be computed for a gross head in the pipe of 84.935 m

$$N = \left( \frac{3.82 \times 173}{9.81 \times 84.935 \times 3} \right)^2 = 0.070$$

and therefore

$$\Delta_p = 84.935 \left( \frac{0.07}{2} \pm \sqrt{0.07 + \frac{0.07^2}{4}} \right) = +25.65 \text{ m}; -19.58 \text{ m}$$

The total pressure would be 84.935+25.65 = 110.585 tf/m<sup>2</sup> = 11.06 kN/mm<sup>2</sup>.

It requires a wall thickness:

$$e = \frac{11.06 \times 1000}{2 \times 1400} + 1 = 4.95 \text{ mm}$$

That agrees with the initial estimation and covers the specification for handling the pipes in the field (t<sub>min</sub>=2.5x1+1.2=3.7 mm)

To compute the air vent pipe diameter:

$$P_c = 882500 \left( \frac{5}{1000} \right)^3 = 0.11 \text{ kN} / \text{mm}^2$$

And the diameter:

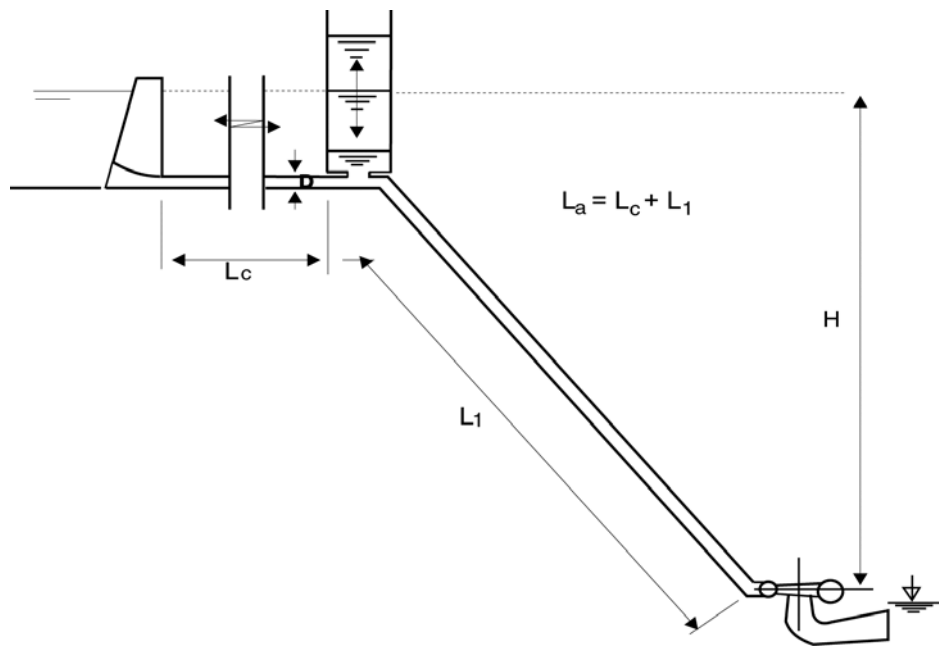
$$d = 7.47 \sqrt{\frac{3}{\sqrt{0.11}}} = 22.46 \text{ cm}$$

The waterhammer problem becomes acute in long pipes, when the open channel is substituted by a pressure pipe all along the race. For a rigorous approach it is necessary to take into consideration not only the elasticity of fluid and pipe material, as above, but also the hydraulic losses and the closure time of the valve. The mathematical approach is cumbersome and requires the use of a computer program. For interested readers, Chaudry 19, Rich 20, and Streeter and Wylie 21 give some calculation methods together with a certain number of worked examples.

To determine the minimum pipe thickness required at any point along the penstock two water hammer hypotheses should be taken into consideration: normal water hammer and emergency water hammer. Normal water hammer occurs when the turbine shuts down under governor control. Under these conditions, the overpressure in the penstock can reach 25% of the gross head, in the case of Pelton turbines, and from 25% to 50% in the case of reaction turbines (depending on the governor time constants). The turbine manufacturer's advice should be taken into consideration. Emergency water hammer, caused for example by an obstruction in the needle valve of a Pelton turbine, or a malfunction of the turbine control system, must be calculated according to the aforementioned equation.

In steel penstocks, the compounded stresses (static plus transitory) are a function both of the ultimate tensile and yield strength. In the case of normal water hammer, the combined stress should be under 60% of the yield strength and 38% of the ultimate tensile strength. In the case of emergency water hammer, the combined stresses should be under 96% of the yield strength and 61% of the ultimate tensile strength.

Commercial pipes are often rated according to the maximum working pressure under which they are designed to operate. The pressure rating of a pipe already includes a safety factor, and sometimes may include an allowance for surge pressures. Safety factors and surge pressure allowances depend on the standards being used.



**Figure 5.36: Surge tower**

If the scheme is liable to surge pressure waves a device to reduce its effects must be considered. The simplest device is the surge tower, a sort of large tube, connected at its base to the penstock and open to the atmosphere. The fundamental action of a surge tower is to reduce the length of the column of water by placing a free water surface closer to the turbine (Figure 5.36). Some authors consider that the surge tower is unnecessary if the pipe length is inferior to 5 times the gross head. It is also convenient to take into account the water acceleration constant  $t_h$  in the pipe:

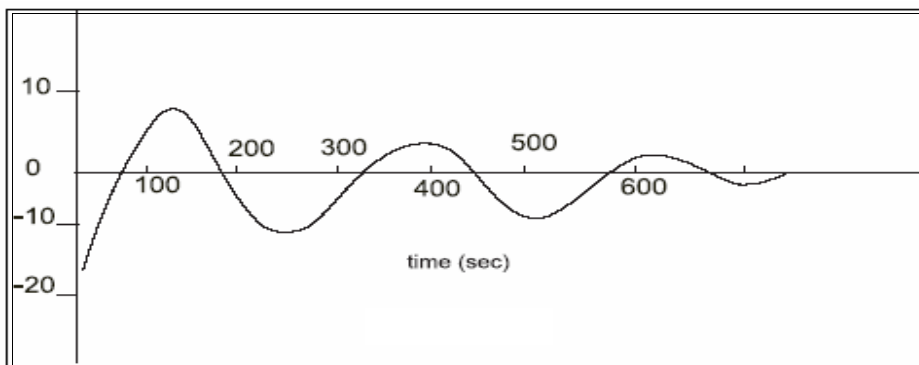
$$t_h = \frac{V \cdot L}{gH} \tag{5.27}$$

where

$L$  = length of penstock (m),

$V$  = flow velocity (m/s) and

$H$  = net head (m).



**Figure 5.37: Surge height versus time**



**Photo 5.19: Water jet**

If  $t_h$  is inferior to 3 seconds the surge tower is unnecessary but if it surpasses 6 seconds, either a surge tower or another correcting device must be installed to avoid strong oscillations in the turbine controller.

With the valve open and a steady flow in the penstock, the level of the water in the tower will correspond to the pressure in the penstock - equivalent to the net head. When by a sudden closure of the valve the pressure in the penstock rises abruptly, the water in the penstock tends to flow into the tower, raising the level of the water above the level in the intake. The level in the tower then begins to fall as the water flows from the tower into the penstock, until a minimum level is reached. The flow then reverses and the level in the tower rise again and so on. Figure 5.37 shows a graph plotting the surge height versus time. The maximum height corresponds to the overpressure in the penstock due to the waterhammer. The throttling introduced by a restricted orifice will reduce the surge amplitude by 20 to 30 per cent. The time  $t_h$  plays an important role in the design of the turbine regulation system. In a badly designed system, the governor and the tower surge can interact, generating speed regulation problems too severe for the governor to cope with.

In instances, when the closure time of the turbine valves must be rapid, a relief valve placed in parallel with the turbine, such that it opens as the turbine wicket gates close, can be convenient. This has the effect of slowing down the flow changes in the penstock<sup>5</sup>. Photo 5.19 shows the water jet ejecting from the open valve.

### **Saddles, supporting blocks and expansion joints**

The saddles are designed to support the weight of the penstock full of water, but not to resist significant longitudinal forces. The vertical component of the weight to be supported, in kN, has a value of:

$$F1=(Wp+Ww) \cdot L \cdot \cos\Phi \quad (5.28)$$

where

$W_p$  = weight of pipe per metre (kN/m)

$W_w$  = weight of water per metre of pipe (kN/m)

$L$  = length of pipe between mid points of each span (m)

$\Phi$  = angle of pipe with horizontal

The design of support rings is based on the elastic theory of thin cylindrical shells. The pipe shell is subject to beam and hoop stresses, and the loads are transmitted to the support ring by shear. If penstocks are continuously supported at a number of points, the bending moment at any point of penstock may be calculated assuming that it is a continuous beam, and using the corresponding equation. The rings are welded to the pipe shell with two full length fillet welds and are tied together with diaphragm plates

The span between supports  $L$  is determined by the value of the maximum permissible deflection  $L/65000$ . Therefore the maximum length between supports is given by the equation:

$$L = 182.61 \cdot \sqrt[3]{\frac{(D + 0.0147)^4 - D^4}{P}} \tag{5.29}$$

where  $D$  = internal diameter (m) and  $P$  = unit weight of the pipe full of water (kg/m).

### **5.10 Tailraces**

After passing through the turbine the water returns to the river trough a short canal called a tailrace. Impulse turbines can have relatively high exit velocities, so the tailrace should be designed to ensure that the powerhouse would not be undermined. Protection with rock riprap or concrete aprons should be provided between the powerhouse and the stream. The design should also ensure that during relatively high flows the water in the tailrace does not rise so far that it interferes with the turbine runner. With a reaction turbine the level of the water in the tailrace influences the operation of the turbine and more specifically the onset of cavitation. This level also determines the available net head and in low head systems may have a decisive influence on the economic results.

## **BIBLIOGRAPHY**

1. <http://www.obermeyhydro.com>
2. H.C. Huang and C.E. Hita, “Hydraulic Engineering Systems”, Prentice Hall Inc., Englewood Cliffs, New Jersey 1987.
3. British Hydrodynamic Research Association, “Proceedings of the Symposium on the Design and Operation of Siphon Spillways”, London 1975.
4. Allen R. Inversin, “Micro-Hydropower Sourcebook”, NRECA International Foundation, Washington, D.C.
5. USBR, “Design of Small Canal Structure”, Denver Colorado, 1978a.
6. USBR, “Hydraulic Design of Spillways and Energy Dissipaters”, Washington DC, 1964.
7. T. Moore, “TLC for small hydro: good design means fewer headaches”, HydroReview, April 1988.
8. T.P. Tung y otros, “Evaluation of Alternative Intake Configuration for Small Hydro”, Actas de HIDROENERGIA 93. Munich.
9. ASCE, Committee on Intakes, “Guidelines for the Design of Intakes for Hydroelectric Plants”, 1995.
10. G. Munet y J.M. Compas, “PCH de recuperation d’energie au barrage de “Le Pouzin””, Actas de HIDROENERGIA 93, Munich.
11. G. Schmausser & G. Hartl, “Rubber seals for steel hydraulic gates”, Water Power & Dam Construction September 1998.
12. ISO 161-1-1996 “Thermoplastic pipes for conveyance of fluids – Nominal outside diameters and nominal pressures – Part 1: Metric series.”
13. ISO 3606-1976 “Unplasticized polyvinyl chloride (PVC) pipes. Tolerances on outside diameters and wall thickness.”
14. ISO 3607-1977 “Polyethylene (PE) pipes. Tolerance on outside diameters and wall thickness.”
15. ISO 3609-1977 “Polypropylene (PP) pipes. Tolerances on outside diameters and wall thickness.”
16. ISO 4065-1996 “Thermoplastic pipes – Universal wall thickness table.”
17. H. Chaudry, “Applied Hydraulic Transients”, Van Nostrand Reinhold Company, 1979.
18. J. Parmakian, “Waterhammer Analyses”, Dover Publications, Inc, New York, 1963.

19. Electrobras (Centrais Eléctricas Brasileiras S.A.) “Manual de Minicentraís Hidrelétricas.”
20. M. Bouvard, “Mobile barrages and intakes on sediment transporting rivers” IAHR Monograph, AA Balkema, 1984.
21. Sinniger & Hager, “Constructions Hydrauliques”, PPUR, Lausanne, 1989.

---

<sup>1</sup> By Erik Bollaert (LCH-EPFL), Jonas Rundqvist (SERO) and Celso Penche (ESHA)

<sup>2</sup> J.L. Brennac. “Les Hauses Hydroplus”, ESHA Info n° 9 Estate 1993

<sup>3</sup> USBR “Design of Small Dams” - 3rd ed., Denver, Colorado, 1987.

<sup>4</sup> One of these, the SSSS (Serpent Sediment Sluicing System) has been described in detail in the issue 9 -spring/summer 1993- of ESHA Info

<sup>5</sup> In the ESHA NEWS issue of spring 1991 there is a description of such a valve.

## CHAPTER 6: ELECTROMECHANICAL EQUIPMENT

### CONTENTS

6	Electromechanical equipment .....	154
6.1	Powerhouse .....	154
6.2	Hydraulic turbines.....	156
6.2.1	Types and configuration.....	156
6.2.2	Specific speed and similitude.....	168
6.2.3	Preliminary design .....	171
6.2.4	Turbine selection criteria .....	174
6.2.5	Turbine efficiency .....	181
6.3	Speed increasers.....	184
6.3.1	Speed increaser types .....	184
6.3.2	Speed increaser design.....	185
6.3.3	Speed increaser maintenance .....	186
6.4	Generators.....	186
6.4.1	Generator configurations.....	188
6.4.2	Exciters.....	188
6.4.3	Voltage regulation and synchronisation.....	189
	Asynchronous generators.....	189
6.5	Turbine control.....	189
6.6	Switchgear equipment.....	192
6.7	Automatic control .....	193
6.8	Ancillary electrical equipment.....	194
6.8.1	Plant service transformer .....	194
6.8.2	DC control power supply .....	194
6.8.3	Headwater and tailwater recorders.....	194
6.8.4	Outdoor substation .....	195
6.9	Examples.....	196

### LIST OF FIGURES

Figure 6.1	: Schematic view of a powerhouse –Low head .....	155
Figure 6.2	: Schematic view of a powerhouse –high and medium heads .....	155
Figure 6.3	: Schematic view of a hydropower scheme and of the measurement sections.....	157
Figure 6.4	: Cross section of a nozzle with deflector.....	158
Figure 6.5	: View of a two nozzles horizontal Pelton.....	159
Figure 6.6	: View of a two nozzle vertical Pelton.....	159
Figure 6.7	: Principle of a Turgo turbine .....	160
Figure 6.8	: Principle of a Cross-flow turbine .....	160
Figure 6.9	: Guide vane functioning principle .....	162
Figure 6.10	: View of a Francis Turbine.....	162
Figure 6.11	: Kinetic energy remaining at the outlet of the runner.....	163
Figure 6.12	: Cross section of a double regulated Kaplan turbine.....	164
Figure 6.13	: Cross section of a double regulated Bulb turbine.....	164



Figure 6.14 : Cross section of a vertical Kaplan .....	166
Figure 6.15 : Cross section of a Kaplan siphon power plant .....	166
Figure 6.16 : Cross section of a Kaplan inverse siphon power plant.....	166
Figure 6.17 : Cross section of an inclined Kaplan power plant .....	166
Figure 6.18 : Cross section of a S Kaplan power plant.....	166
Figure 6.19 : Cross section of an inclined right angle Kaplan power plant.....	166
Figure 6.20 : Cross section of a pit Kaplan power plant.....	167
Figure 6.21 : Design of turbine runners in function of the specific speed $n_s$ .....	169
Figure 6.22 : Specific speed in function of the net head $H_n = E/g$ .....	170
Figure 6.23 : Nozzle characteristic .....	172
Figure 6.24 : Cross section of a Francis Runner .....	172
Figure 6.25 : Cross section of a Kaplan turbine.....	173
Figure 6.26 : Turbines' type field of application.....	175
Figure 6.27 : Cavitation limits .....	179
Figure 6.28 : Efficiency measurement on a real turbine built without laboratory development. ....	181
Figure 6.29 : Schematic view of the energy losses in an hydro power scheme.....	182
Figure 6.30 : Typical small hydro turbines efficiencies.....	183
Figure 6.31: Parallel shaft speed increaser.....	185
Figure 6.32: Bevel gear speed increaser .....	185
Figure 6.33: Belt speed increaser.....	185
Figure 6.34 : Vertical axis generator directly coupled to a Kaplan turbine .....	188
Figure 6.35 : Mechanical speed governor .....	191
Figure 6.36 Level measurement.....	195

## **LIST OF TABLES**

Table 6.1: Kaplan turbines configuration .....	165
Table 6.2: Range of specific speed for each turbine type .....	170
Table 6.3: Range of heads.....	175
Table 6.4 : Flow and head variation acceptance .....	176
Table 6.5: Generator synchronisation speed .....	180
Table 6.6: Runaway speeds of turbines .....	180
Table 6.7 : Typical efficiencies of small turbines.....	184
Table 6.8: Typical efficiencies of small generators .....	187

## **LIST OF PHOTOS**

Photo 6.1 Overview of a typical powerhouse .....	156
Photo 6.2: Pelton runner .....	159
Photo 6.3: Horizontal axis Francis turbine.....	161
Photo 6.4: Horizontal axis Francis turbine guide vane operating device.....	162
Photo 6.5: Francis runner .....	162
Photo 6.6 : Kaplan runner .....	164
Photo 6.7: Siphon Kaplan .....	167

## 6 ELECTROMECHANICAL EQUIPMENT<sup>1</sup>

This chapter gives the main description of the electromechanical equipment, some preliminary design rules and some selection criterion. For more technical description, please refer to L. Vivier<sup>2</sup>, J. Raabe<sup>3</sup> books and others publications<sup>4 5 6 7 8 9 10</sup>.

### 6.1 Powerhouse

In a small hydropower scheme the role of the powerhouse is to protect the electromechanical equipment that convert the potential energy of water into electricity, from the weather hardships. The number, type and power of the turbo-generators, their configuration, the scheme head and the geomorphology of the site determine the shape and size of the building.

As shown in figures 6.1 and 6.2, the following equipment will be displayed in the powerhouse:

- Inlet gate or valve
- Turbine
- Speed increaser (if needed)
- Generator
- Control system
- Condenser, switchgear
- Protection systems
- DC emergency supply
- Power and current transformers
- etc.

Fig. 6.1 is a schematic view of an integral intake indoor powerhouse suitable for low head schemes. The substructure is part of the weir and embodies the power intake with its trashrack, the vertical axis Kaplan turbine coupled to the generator, the draft tube and the tailrace. The control equipment and the outlet transformers are located in the generator forebay.

In order to mitigate the environmental impact the powerhouse can be entirely submerged (see chapter 1, figure 1.6). In this way the level of sound is sensibly reduced and the visual impact is nil.

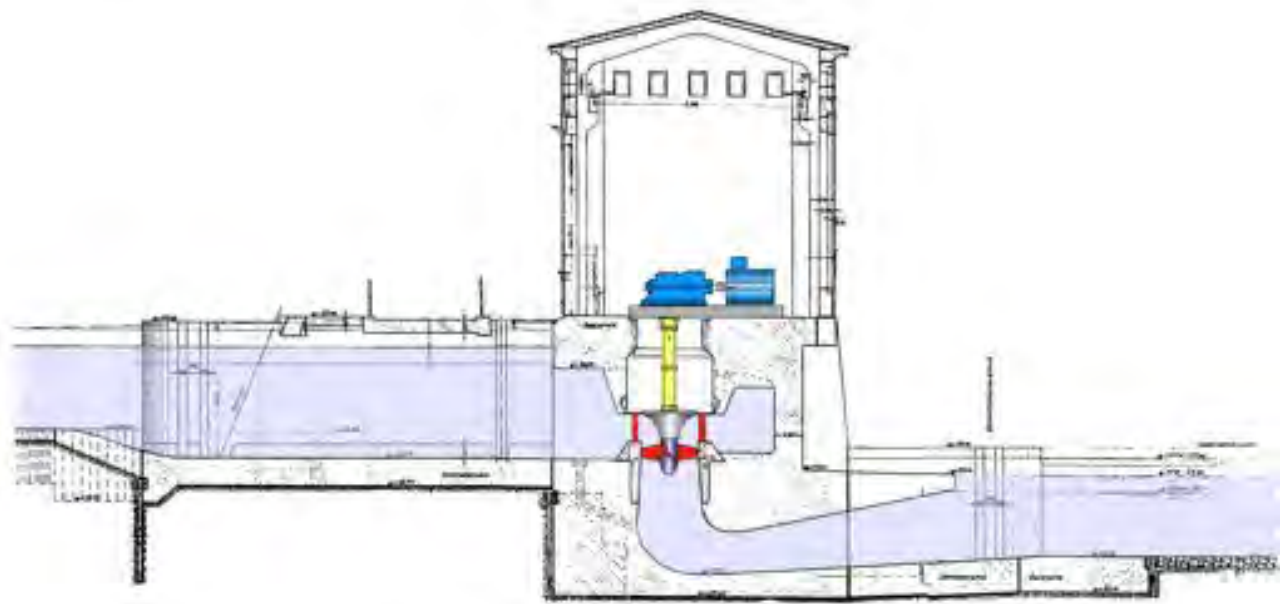


Figure 6.1: Schematic view of a powerhouse –Low head

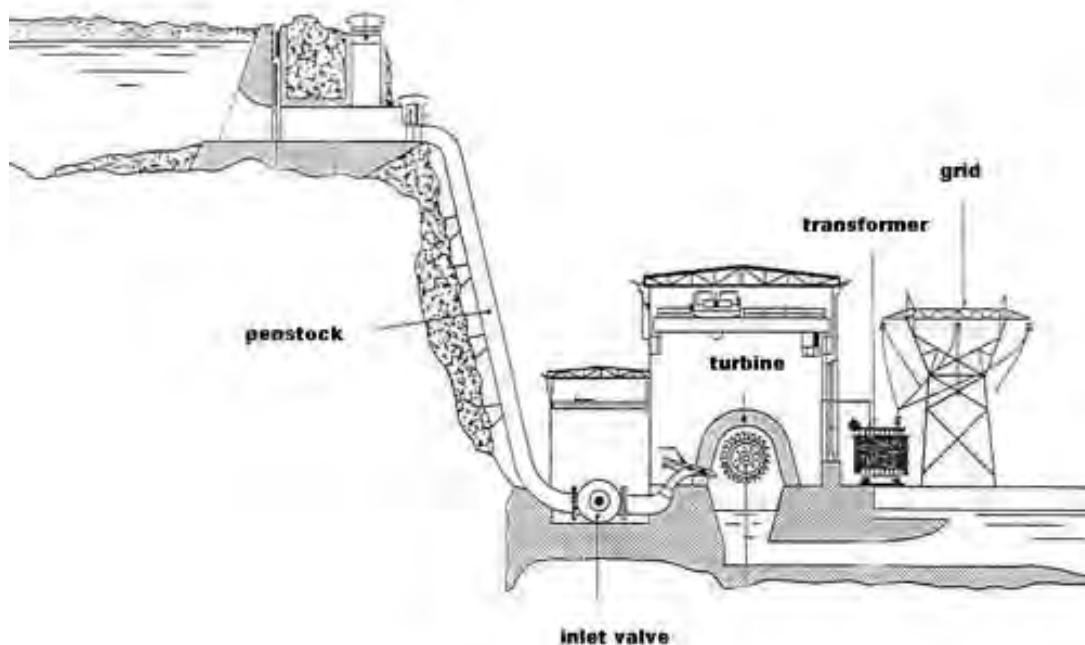


Figure 6.2: Schematic view of a powerhouse –high and medium heads

In medium and high head schemes, powerhouses are more conventional (see figure 6.2) with an entrance for the penstock and a tailrace. Although not usual, this kind of powerhouse can be underground.



**Photo 6.1: Overview of a typical powerhouse**

The powerhouse can also be at the base of an existing dam, where the water arrives via an existing bottom outlet or an intake tower. Figure 1.4 in chapter 1 illustrates such a configuration.

As we will see in chapter 6.1.1.2, some turbines configurations allow for the whole superstructure itself, to be dispensed with, or reduced enclosing only the switchgear and control equipment. Integrating the turbine and generator in a single waterproofed unit that can be installed directly in the waterway means that a conventional powerhouse is not required (bulb or siphon units).

## **6.2 Hydraulic turbines**

The purpose of a hydraulic turbine is to transform the water potential energy to mechanical rotational energy. Although this handbook does not define guidelines for the design of turbines (a role reserved for the turbine manufacturers) it is appropriate to provide a few criteria to guide the choice of the right turbine for a particular application and even to provide appropriate formulae to determine its main dimensions. These criteria and formulae are based on work undertaken by Siervo and Lugaresi<sup>11</sup>, Siervo and Leva<sup>12 13</sup>, Lugaresi and Massa<sup>14 15</sup>, Austerre and Verdehan<sup>16</sup>, Giraud and Beslin<sup>17</sup>, Belhaj<sup>18</sup>, Gordon<sup>19 20</sup>, Schweiger and Gregori<sup>21 22</sup> and others, which provide a series of formulae by analysing the characteristics of installed turbines. It is necessary to emphasize however that no advice is comparable to that provided by the manufacturer, and every developer should refer to manufacturer from the beginning of the development project.

All the formulae of this chapter use SI units and refer to IEC standards (IEC 60193 and 60041).

### **6.2.1 Types and configuration**

The potential energy in water is converted into mechanical energy in the turbine, by one of two fundamental and basically different mechanisms:

- The water pressure can apply a force on the face of the runner blades, which decreases as it proceeds through the turbine. Turbines that operate in this way are called reaction turbines. The turbine casing, with the runner fully immersed in water, must be strong enough to withstand the operating pressure. Francis and Kaplan turbines belong to this category.

- The water pressure is converted into kinetic energy before entering the runner. The kinetic energy is in the form of a high-speed jet that strikes the buckets, mounted on the periphery of the runner. Turbines that operate in this way are called impulse turbines. The most usual impulse turbine is the Pelton.

This chapter describes each turbine type, presented by decreasing head and increasing nominal flow. The higher the head, the smaller the flow.

The hydraulic power at disposition of the turbine is given by:

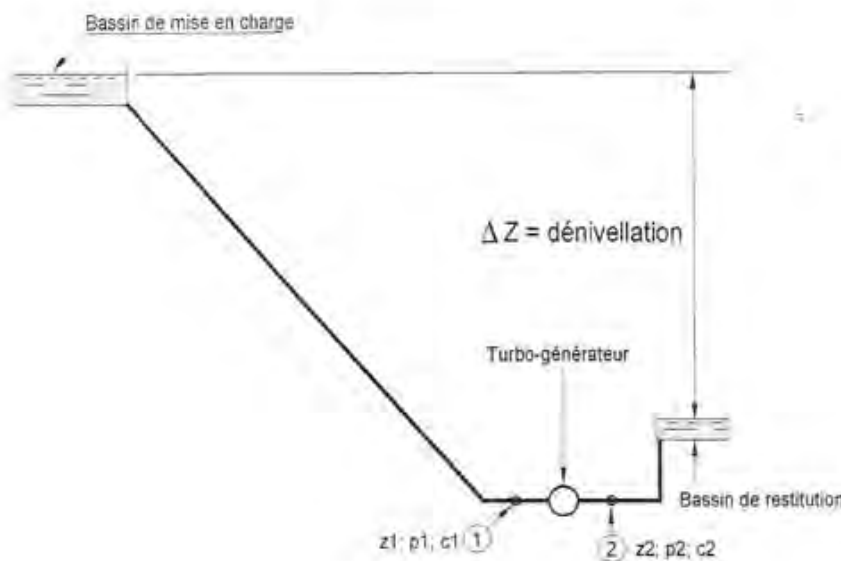
$$P_h = \rho Q \cdot gH \quad [W] \quad (6.1)$$

- Where:
- $\rho Q$  = mass flow rate [kg/s]
  - $\rho$  = water specific density [kg/m<sup>3</sup>]
  - $Q$  = Discharge [m<sup>3</sup>/s]
  - $gH$  = specific hydraulic energy of machine [J/kg]
  - $g$  = acceleration due to gravity [m/s<sup>2</sup>]
  - $H$  = "net head" [m]

The mechanical output of the turbine is given by:

$$P_{mec} = P_h \cdot \eta \quad [W] \quad (6.2)$$

- $\eta$  = turbine efficiency [-]



**Figure 6.3: Schematic view of a hydropower scheme and of the measurement sections**

The specific hydraulic energy of machine is defined as follows:

$$E = gH = \frac{1}{\rho} \cdot (p_1 - p_2) + \frac{1}{2} \cdot (c_1^2 - c_2^2) + g \cdot (z_1 - z_2) \quad [\text{m}] \quad (6.3)$$

- Where:
- $gH$  = specific hydraulic energy of machine [J/kg]
  - $p_x$  = pressure in section x [Pa]
  - $c_x$  = water velocity in section x [m/s]
  - $z_x$  = elevation of the section x [m]

The subscripts 1 and 2 define the upstream and downstream measurement section of the turbine. They are defined by IEC standards.

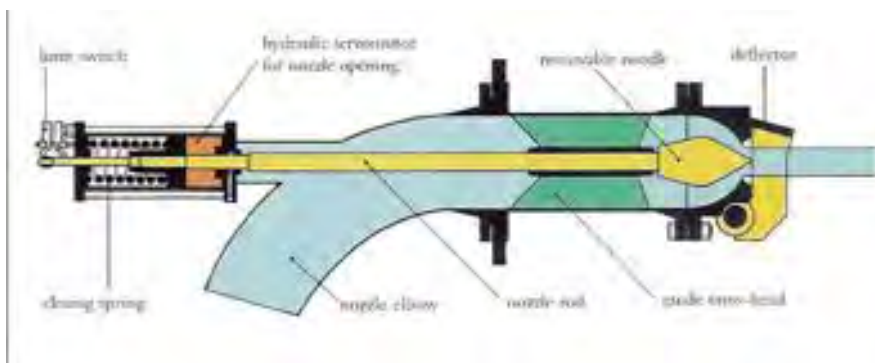
The net head is defined as:

$$H_n = \frac{E}{g} \quad [\text{m}] \quad (6.4)$$

*Impulse turbines*

Pelton turbines

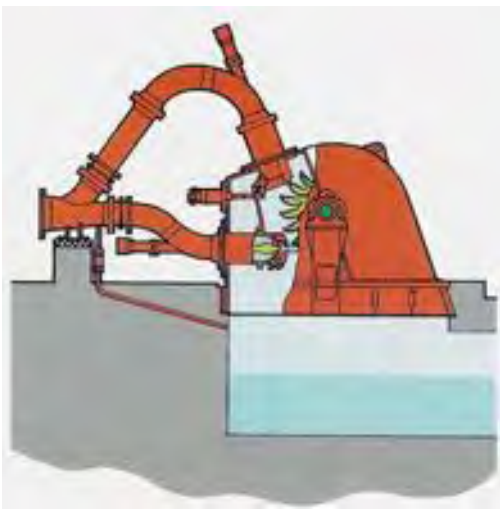
Pelton turbines are impulse turbines where one or more jets impinge on a wheel carrying on its periphery a large number of buckets. Each jet issues water through a nozzle with a needle valve to control the flow (figure 6.4). They are only used for high heads from 60 m to more than 1 000 m. The axes of the nozzles are in the plan of the runner. In case of an emergency stop of the turbine (e.g. in case of load rejection), the jet may be diverted by a deflector so that it does not impinge on the buckets and the runner cannot reach runaway speed. In this way the needle valve can be closed very slowly, so that overpressure surge in the pipeline is kept to an acceptable level (max 1.15 static pressure).



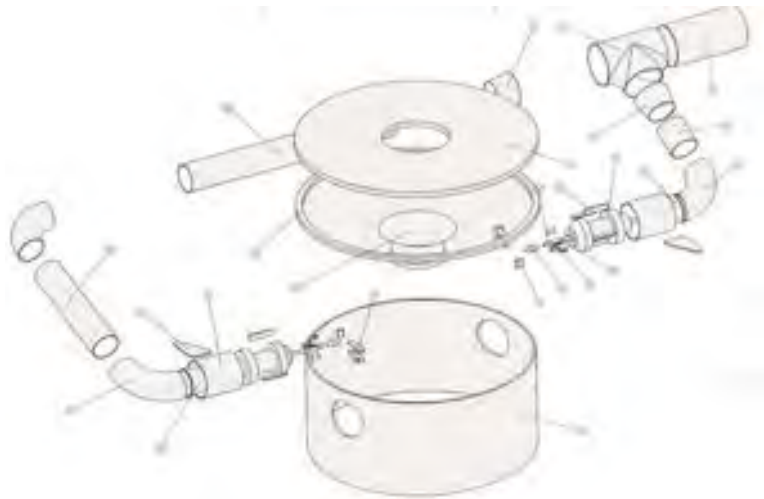
**Figure 6.4: Cross section of a nozzle with deflector**

As any kinetic energy leaving the runner is lost, the buckets are designed to keep exit velocities to a minimum.

One or two jet Pelton turbines can have horizontal or vertical axis, as shown in figure 6.5. Three or more nozzles turbines have vertical axis (see figure 6.6). The maximum number of nozzles is 6 (not usual in small hydro).



**Figure 6.5: View of a two nozzles horizontal Pelton**



**Figure 6.6: View of a two nozzle vertical Pelton**



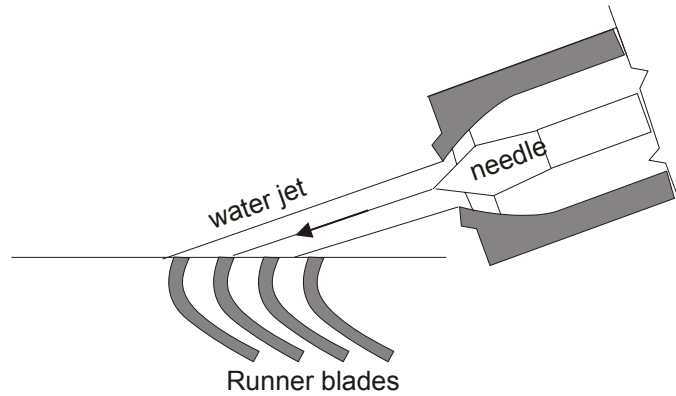
**Photo 6.2: Pelton runner**

The turbine runner is usually directly coupled to the generator shaft and shall be above the downstream level. The turbine manufacturer can only give the clearance.

The efficiency of a Pelton is good from 30% to 100% of the maximum discharge for a one-jet turbine and from 10% to 100% for a multi-jet one.

Turgo turbines

The Turgo turbine can operate under a head in the range of 50-250 m. Like the Pelton, it is an impulse turbine, however its buckets are shaped differently and the jet of water strikes the plane of its runner at an angle of 20°. Water enters the runner through one side of the runner disk and emerges from the other (Figure 6.7). It can operate between 20% and 100% of the maximal design flow.



**Figure 6.7: Principle of a Turgo turbine**

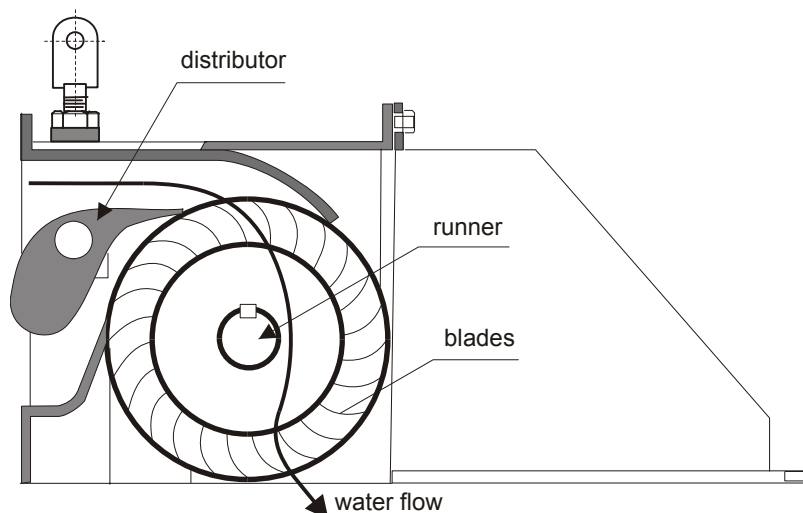
The efficiency is lower than for the Pelton and Francis turbines.

Compared to the Pelton, a Turgo turbine has a higher rotational speed for the same flow and head.

A Turgo can be an alternative to the Francis when the flow strongly varies or in case of long penstocks, as the deflector allows avoidance of runaway speed in the case of load rejection and the resulting water hammer that can occur with a Francis.

Cross-flow turbines

This impulse turbine, also known as Banki-Michell is used for a wide range of heads overlapping those of Kaplan, Francis and Pelton. It can operate with heads between 5 and 200 m.



**Figure 6.8: Principle of a Cross-flow turbine**



Water (figure 6.8) enters the turbine, directed by one or more guide-vanes located upstream of the runner and crosses it two times before leaving the turbine.

This simple design makes it cheap and easy to repair in case of runner brakes due to the important mechanical stresses.

The Cross-flow turbines have low efficiency compared to other turbines and the important loss of head due to the clearance between the runner and the downstream level should be taken into consideration when dealing with low and medium heads. Moreover, high head cross-flow runners may have some troubles with reliability due to high mechanical stress.

It is an interesting alternative when one has enough water, defined power needs and low investment possibilities, such as for rural electrification programs.

### *Reaction turbines*

#### Francis turbines.

Francis turbines are reaction turbines, with fixed runner blades and adjustable guide vanes, used for medium heads. In this turbine the admission is always radial but the outlet is axial. Photograph 6.3 shows a horizontal axis Francis turbine. Their usual field of application is from 25 to 350 m head.

As with Peltons, Francis turbines can have vertical or horizontal axis, this configuration being really common in small hydro.

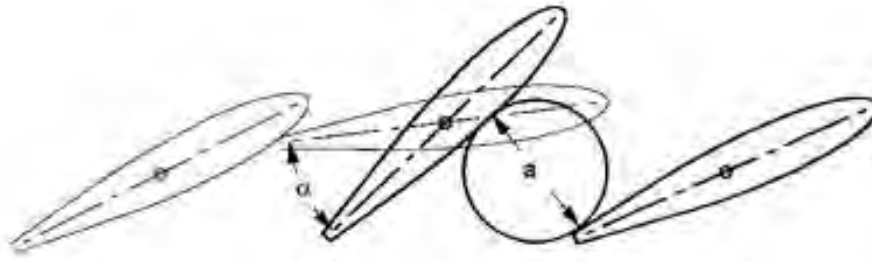


**Photo 6.3: Horizontal axis Francis turbine**

Francis turbines can be set in an open flume or attached to a penstock. For small heads and power open flumes were commonly employed, however nowadays the Kaplan turbine provides a better technical and economical solution in such power plants.

The water enters the turbine by the spiral case that is designed to keep its tangential velocity constant along the consecutive sections and to distribute it peripherally to the distributor. As shown in figure 6.9, this one has mobile guide vanes, whose function is to control the discharge going into the runner and adapt the inlet angle of the flow to the runner blades angles. They rotate around their axes by connecting rods attached to a large ring that synchronise the movement of all vanes. They can be used to shut off the flow to the turbine in emergency situations, although their use does not

preclude the installation of a butterfly valve at the entrance to the turbine. The runner transforms the hydraulic energy to mechanical energy and returns it axially to the draft tube.



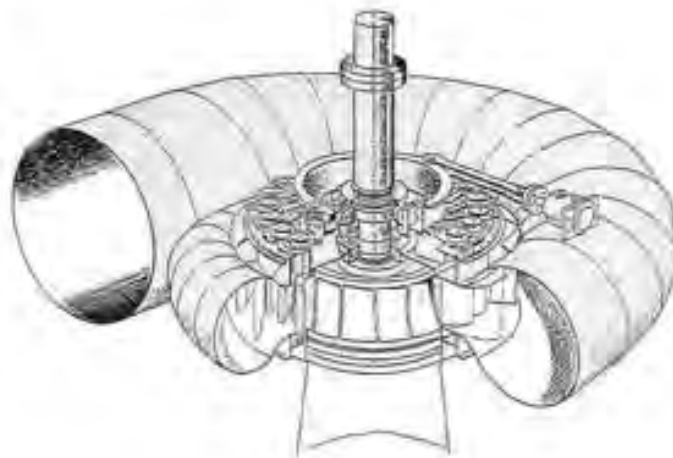
**Figure 6.9: Guide vane functioning principle**



**Photo 6.4: Horizontal axis Francis turbine guide vane operating device**



**Photo 6.5: Francis runner**

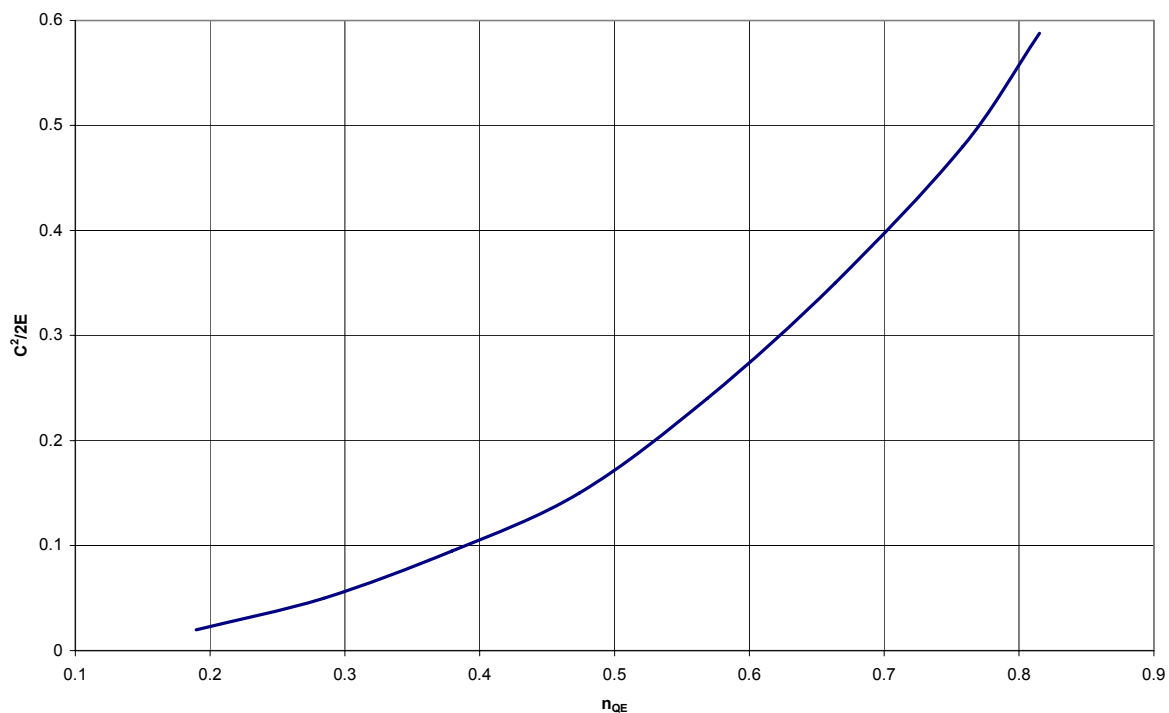


**Figure 6.10: View of a Francis Turbine**

Small hydro runners are usually made in stainless steel castings. Some manufacturers also use aluminium bronze casting or welded blades, which are generally directly coupled to the generator shaft.

The draft tube of a reaction turbine aims to recover the kinetic energy still remaining in the water leaving the runner. As this energy is proportional to the square of the velocity one of the draft tube objectives is to reduce the turbine outlet velocity. An efficient draft tube would have a conical section but the angle cannot be too large, otherwise flow separation will occur. The optimum angle is 7° but to reduce the draft tube length, and therefore its cost, sometimes angles are increased up to 15°.

The lower head, the more important the draft tube is. As low head generally implies a high nominal discharge, the remaining water speed at the outlet of the runner is quite important. One can easily understand that for a fixed runner diameter, the speed will increase if the flow does. Figure 6.11 shows the kinetic energy remaining at the runner outlet as a function of the specific speed (see chapter 6.1.2 for the definition of specific speed).



**Figure 6.11: Kinetic energy remaining at the outlet of the runner.**

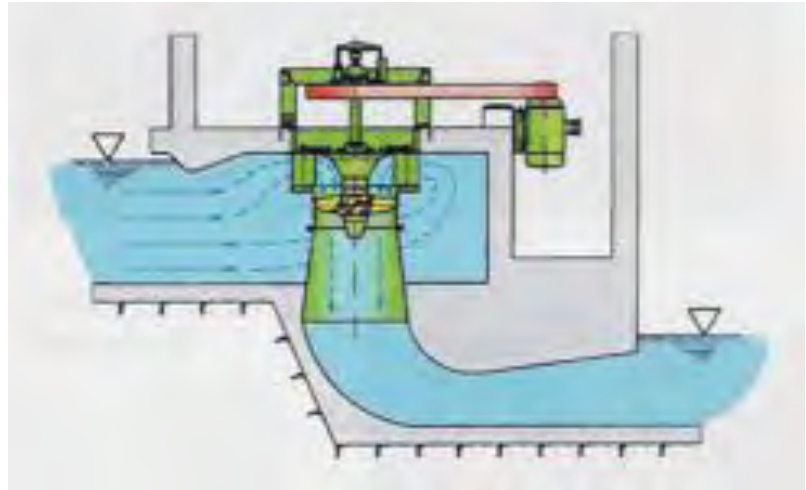
Kaplan and propeller turbines

Kaplan and propeller turbines are axial-flow reaction turbines; generally used for low heads from 2 to 40 m. The Kaplan turbine has adjustable runner blades and may or may not have adjustable guide- vanes. If both blades and guide-vanes are adjustable it is described as "double-regulated". If the guide-vanes are fixed it is "single-regulated". Fixed runner blade Kaplan turbines are called propeller turbines. They are used when both flow and head remain practically constant, which is a characteristic that makes them unusual in small hydropower schemes.

The double regulation allows, at any time, for the adaptation of the runner and guide vanes coupling to any head or discharge variation. It is the most flexible Kaplan turbine that can work between 15% and 100% of the maximum design discharge. Single regulated Kaplan allows a good adaptation to varying available flow but is less flexible in the case of important head variation. They can work between 30% and 100% of the maximum design discharge.

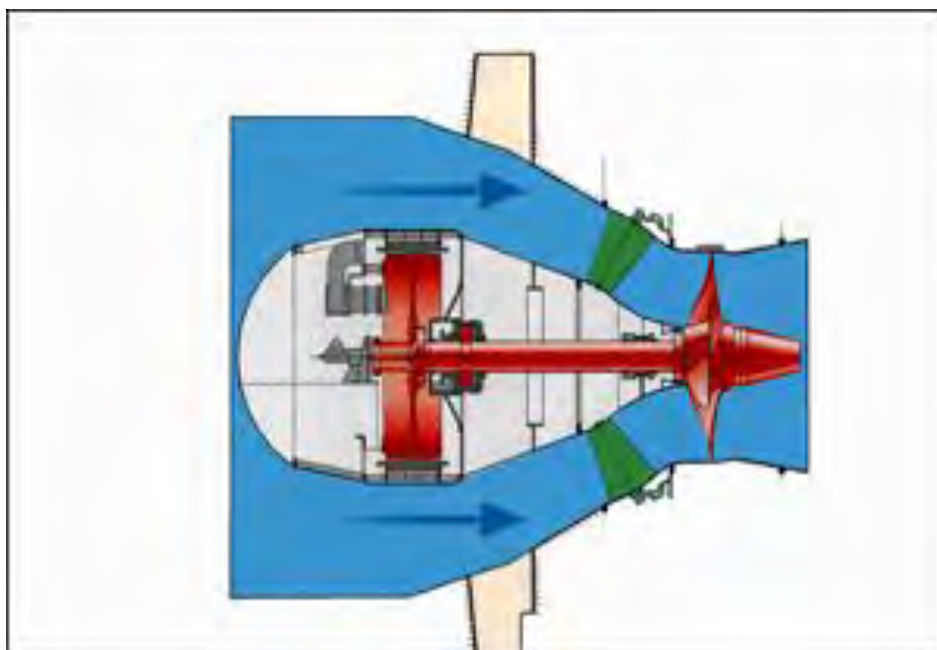


**Photo 6.6: Kaplan runner**



**Figure 6.12: Cross section of a double regulated Kaplan turbine**

The double-regulated Kaplan illustrated in figure 6.12 is a vertical axis machine with a spiral case and a radial guide vane configuration. The flow enters in a radial manner inward and makes a right angle turn before entering the runner in an axial direction. The control system is designed so that the variation in blade angle is coupled with the guide-vanes setting in order to obtain the best efficiency over a wide range of flows and heads. The blades can rotate with the turbine in operation, through links connected to a vertical rod sliding inside the hollow turbine axis.



**Figure 6.13: Cross section of a double regulated Bulb turbine**

Bulb units are derived from Kaplan turbines, with the generator contained in a waterproofed bulb submerged in the flow. Figure 6.13 illustrates a turbine where the generator (and gearbox if required), cooled by pressurised air, is lodged in the bulb. Only the electric cables, duly protected, leave the bulb.

Kaplan turbines are certainly the machines that allow the most number of possible configurations. The selection is particularly critical in low-head schemes where, in order to be profitable, large discharges must be handled. When contemplating schemes with a head between 2 and 5 m, and a discharge between 10 and 100 m<sup>3</sup>/sec, runners with 1.6 - 3.2 metres diameter are required, coupled through a speed increaser to a generator. The hydraulic conduits in general, and water intakes in particular, are very large and require very large civil works with a cost that generally exceeds the cost of the electromechanical equipment.

In order to reduce the overall cost (civil works plus equipment) and more specifically the cost of the civil works, several configurations have been devised that nowadays are considered as classic.

The selection criteria for such turbines are well known:

- Range of discharges
- Net head
- Geomorphology of the terrain
- Environmental requirements (both visual and sonic)
- Labour cost

The configurations differ by how the flow goes through the turbine (axial, radial, or mixed), the turbine closing system (gate or siphon), and the speed increaser type (parallel gears, right angle drive, belt drive).

For those interested in low-head schemes please read the paper presented by J. Fonkenell to *HIDROENERGIA 91*<sup>23</sup> dealing with selection of configurations. Following table and figures show all the possible configurations.

**Table 6.1: Kaplan turbines configuration**

<b>Configuration</b>	<b>Flow</b>	<b>Closing system</b>	<b>Speed increaser</b>	<b>Figure</b>
Vertical Kaplan	Radial	Guide-vanes	Parallel	6.14
Vertical semi-Kaplan siphon	Radial	Siphon	Parallel	6.15
Inverse semi-Kaplan siphon	Radial	Siphon	Parallel	6.16
Inclined semi-Kaplan siphon	Axial	Siphon	Parallel	6.17
Kaplan S	Axial	Gate valve	Parallel	6.18
Kaplan inclined right angle	Axial	Gate valve	Conical	6.19
Semi-Kaplan in pit	Axial	Gate valve	Parallel	6.20

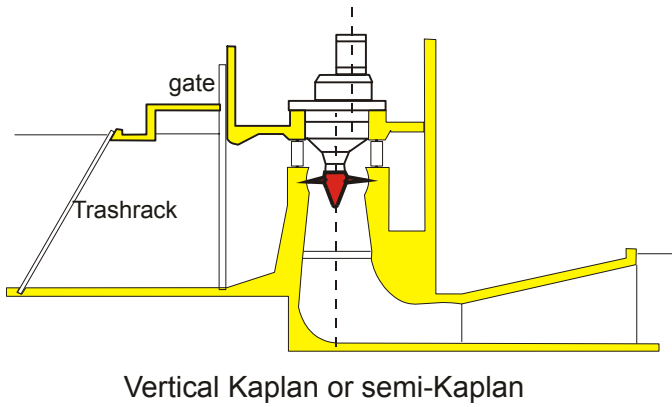


Figure 6.14: Cross section of a vertical Kaplan power plant

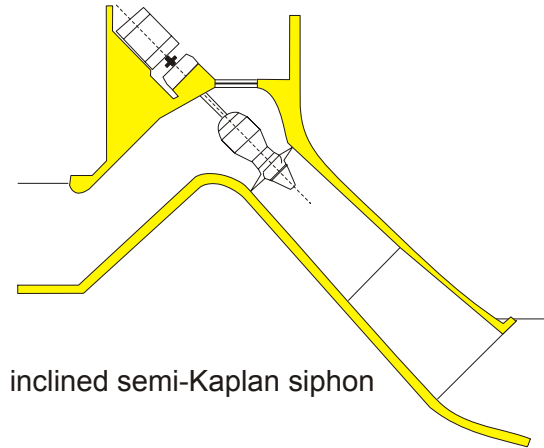


Figure 6.15: Cross section of a Kaplan siphon power plant

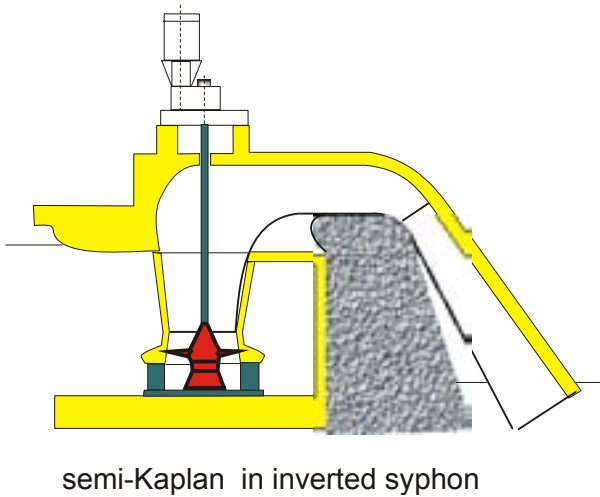


Figure 6.16: Cross section of a Kaplan inverse siphon power plant

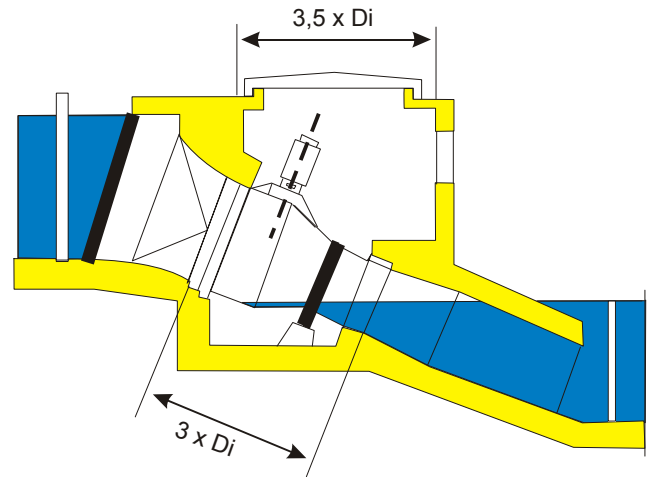


Figure 6.17: Cross section of an inclined Kaplan power plant

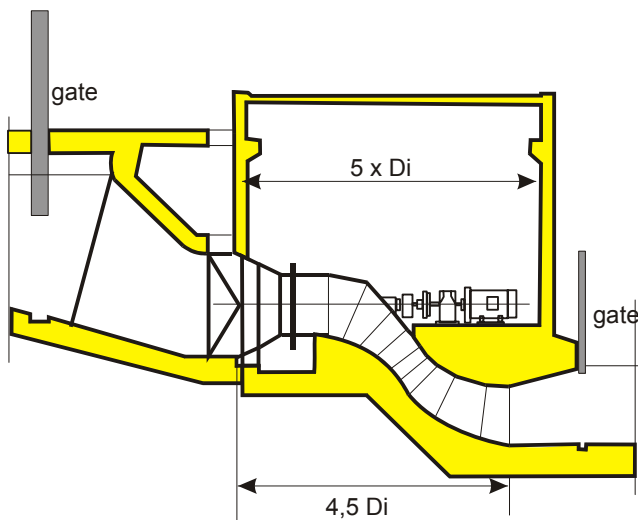


Figure 6.18: Cross section of a S Kaplan power plant

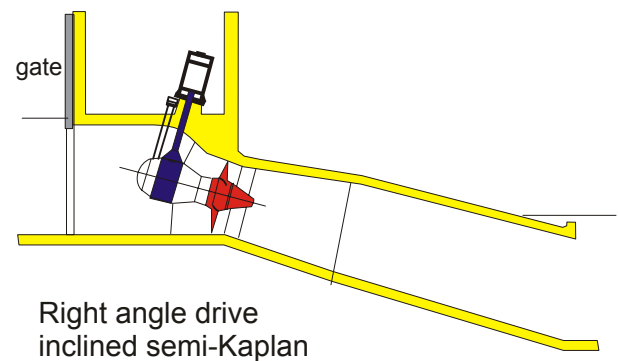
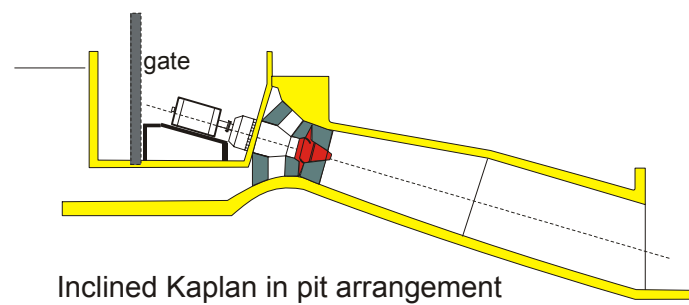


Figure 6.19: Cross section of an inclined right angle Kaplan power plant



**Figure 6.20: Cross section of a pit Kaplan power plant**



**Photo 6.7: Siphon Kaplan**

Siphons are reliable, economic, and prevent runaway turbine speed, however they are noisy if no protection measures are taken to isolate the suction pump and valves during starting and stopping operations. Even if not required for normal operation, a closing gate is strongly recommended as it avoids the unintended starting of the turbine due to a strong variation of upstream and downstream levels. In case of such a problem, the turbine will reach high speeds and the operator will not have the means to stop it. A solution to this problem is the use of flap gate dams.

Underground powerhouses are best at mitigating the visual and sonic impact, but are only viable with an S, a right angle drive or a pit configuration.

The speed increaser configuration permits the use of a standard generator usually turning at 750 or 1 000 rpm, and is also reliable, compact and cheap. The S configuration is becoming very popular, however one disadvantage is that the turbine axis has to cross either the entrance or the outlet pipe with consequent head losses. It is mainly used for medium heads and/or hydropower schemes with penstock.

The pit configuration has the advantage of easy access to all the equipment components, in particular the coupling of turbine and speed increaser, the speed increaser itself and the generator, which facilitates inspection, maintenance and repair. This configuration is popular for very low heads and high discharges allowing a runner diameter bigger than 2 m.

For the same reasons as for the Francis turbines, Kaplans must have a draft tube. Due to the low heads, the kinetic energy is very important and the quality of this part of the turbine should not be neglected.

6.2.2 Specific speed and similitude

The large majority of hydraulic structures, such as spillways, water intakes, etc. are designed and built on the basis of the results obtained from preliminary model studies. The behaviour of these models is based on the principles of hydraulic similitude, including dimensional analysis; the analysis of the physical quantities engaged in the static and dynamic behaviour of water flow in a hydraulic structure. The turbine design does not constitute an exception and actually turbine manufacturers make use of scaled models. The problem of similarity in this case can be summarised as follows: "Given test data on the performance characteristics of a certain type of turbine under certain operating conditions, can the performance characteristic of a geometrically similar machine, under different operating conditions be predicted?" If there is a positive answer to this question the theory of similitude will provide a scientific criterion for cataloguing turbines that will prove very useful in the process of selection of the turbine best adapted to the conditions of the scheme.

- Effectively the answer is positive provided that model and industrial turbine are geometrically similar.

To be geometrically similar the model will be a reduction of the industrial turbine maintaining a fixed ratio for all homogeneous lengths. The physical quantities involved in geometric similarity are length, area *A* and volume. If the length ratio is *k*, the area ratio will be *k*<sup>2</sup> and the volume ratio *k*<sup>3</sup>.

It is particularly important to notice that model tests and laboratory developments are the only way to guarantee the industrial turbines efficiency and hydraulic behaviour. All the similitude rules are strictly defined in international IEC standards 60193 and 60041.

No guarantees can be accepted if not complying with these standards and rules.

According to these standards, the specific speed of a turbine is defined as:

$$n_{QE} = \frac{n \cdot \sqrt{Q}}{E^{\frac{3}{4}}} \quad [-] \quad (6.5)$$

Where:	Q	=	Discharge	[m <sup>3</sup> /s]
	E	=	specific hydraulic energy of machine	[J/kg]
	n	=	rotational speed of the turbine	[t/s]

*n<sub>QE</sub>* is known as specific speed. These parameters characterise any turbine.

As some old and non-standard definitions are still in use, the following conversion factors are given hereafter:

$$v = 2.11 \cdot n_{QE} \quad (6.6)$$

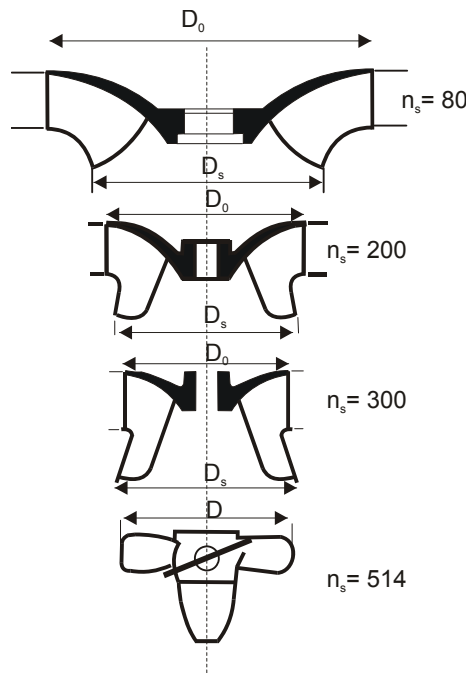
$$n_Q = 333 \cdot n_{QE} \quad (6.7)$$

$$n_s = 995 \cdot n_{QE} \quad (6.8)$$

Equation 6.8 corresponds to the *n<sub>s</sub>* definition calculated with SI units.



Figure 6.21 shows four different designs of runners and their corresponding specific speeds, optimised from the efficiency viewpoint. The lower the specific speed, the higher the corresponding head.



**Figure 6.21: Design of turbine runners in function of the specific speed  $n_s$**

In general turbine manufacturers denote the specific speed of their turbines. A large number of statistical studies on a large number of schemes have established a correlation of the specific speed and the net head for each type of turbine. Some of the correlation formulae are graphically represented in figure 6.22.

Pelton (1 nozzle)  $n_{QE} = \frac{0.0859}{H_n^{0.243}}$  (Siervo and Lugaresi) [-] (6.9)

Francis  $n_{QE} = \frac{1.924}{H_n^{0.512}}$  (Lugaresi and Massa) [-] (6.10)

Kaplan  $n_{QE} = \frac{2.294}{H_n^{0.486}}$  (Schweiger and Gregory) [-] (6.11)

Propeller  $n_{QE} = \frac{2.716}{H_n^{0.5}}$  (USBR) [-] (6.12)

Bulb  $n_{QE} = \frac{1.528}{H_n^{0.2837}}$  (Kpordze and Warnick) [-] (6.13)

Once the specific speed is known the fundamental dimensions of the turbine can be easily estimated. However, one should use these statistical formulae only for preliminary studies as only manufacturers can give the real dimensions of the turbines.

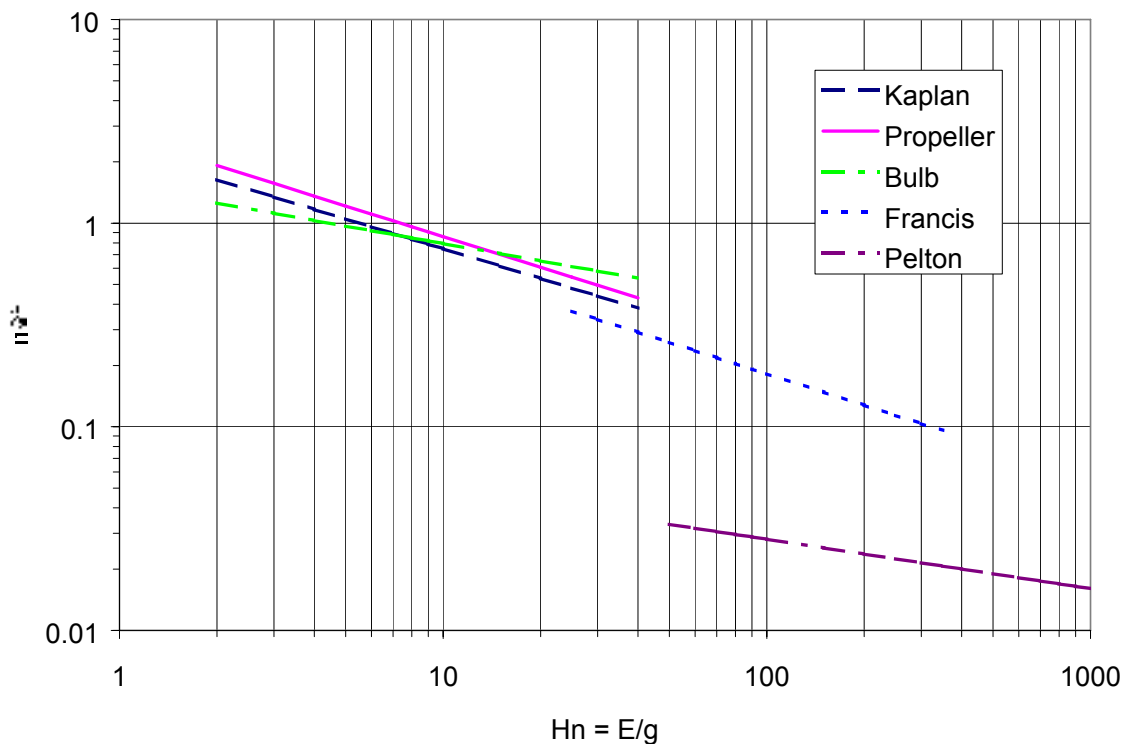
In Pelton turbines, the specific speed increases with the square root of the number of jets. Therefore the specific speed of a four jet Pelton (only exceptionally they do have more than four jets, and then only in vertical axis turbines) is twice the specific speed of one jet Pelton.

Table 6.2 shows the typical specific speed of the main turbines types.

**Table 6.2: Range of specific speed for each turbine type**

Pelton one nozzle	$0.005 \leq n_{QE} \leq 0.025$
Pelton n nozzles	$0.005 \cdot n^{0.5} \leq n_{QE} \leq 0.025 \cdot n^{0.5}$
Francis	$0.05 \leq n_{QE} \leq 0.33$
Kaplan, propellers, bulbs	$0.19 \leq n_{QE} \leq 1.55$

Figure 6.23 shows the specific speed evolution function of the net head and of the turbine type.



**Figure 6.22: Specific speed in function of the net head  $H_n = E/g$ .**

In addition, some basic similarity laws are given hereafter.

$$\frac{Q_t}{Q_m} = \frac{\sqrt{H_t} \cdot D_t^2}{\sqrt{H_m} \cdot D_m^2} \quad [-] \quad (6.14)$$

$$\frac{n_t}{n_m} = \frac{\sqrt{H_t}}{\sqrt{H_m}} \cdot \frac{D_m}{D_t} \quad [-] \quad (6.15)$$

Where t correspond to the industrial turbine and m to the laboratory model.

The following example illustrates the use of the similarity laws.

If we intend to build a model with a 1:5 scale of a turbine working with an 80 m net head at 10 m<sup>3</sup>/s and running at 750 rpm, then to test it under a net head of 10 m, the model discharge will be 0.141 m<sup>3</sup>/s and its rotational speed 1'326 rpm.

Another example is the case where a turbine would be designed for 120 net Head at 1 m<sup>3</sup>/s, and 750 rpm, but is now used under 100 m net head. In this case D<sub>t</sub> = D<sub>m</sub>. In order to work properly, the turbine should have a rotational speed of 685 rpm and the maximum admissible flow would be 0.913 m<sup>3</sup>/s.

### 6.2.3 Preliminary design

This chapter will give some statistical formulae allowing for the determination of the main dimensions of the turbine runner for Pelton, Francis and Kaplan turbines.

It has to be remembered that the turbine design is an iterative process depending on miscellaneous criterion as cavitation limits, rotational speed, specific speed, etc. (see chapter 6.1.4). Clearly, it means that after using the following equation, one has to control that the preliminary designed turbine complies with the above-mentioned criterion.

For all turbine types, the first step is to choose a rotational speed.

#### *Pelton turbines*

If we know the runner speed its diameter can be estimated by the following equations:

$$D_1 = 0.68 \cdot \frac{\sqrt{H_n}}{n} \quad [m] \quad (6.16)$$

$$B_2 = 1.68 \cdot \sqrt{\frac{Q}{n_{jet}} \cdot \frac{1}{\sqrt{H_n}}} \quad [m] \quad (6.17)$$

$$D_e = 1.178 \cdot \sqrt{\frac{Q}{n_{jet}} \cdot \frac{1}{\sqrt{gH}}} \quad [m] \quad (6.18)$$

Where n is the rotational speed in t/s and n<sub>jet</sub>, the number of nozzles.

D<sub>1</sub> is defined as the diameter of the circle describing the buckets centre line. B<sub>2</sub> is the bucket width, mainly depending on the discharge and number of nozzles. D<sub>e</sub> is the nozzle diameter.

As a general rule, the ratio D<sub>1</sub>/ B<sub>2</sub> must always be greater than 2.7. If this is not the case, then a new calculation with a lower rotational speed or more nozzles has to be carried out.

The discharge function of the nozzle opening  $C_p$  - in one jet turbine the total discharge – can be estimated according to the following formulae:

$$Q_{jet} = K_v \cdot \pi \cdot \frac{D_e^2}{4} \cdot \sqrt{2 \cdot gH} \quad [m^3/s] \quad (6.19)$$

Where  $K_v$  is given in the figure 6.23 function of the relative opening  $a = C_p/D_e$ .

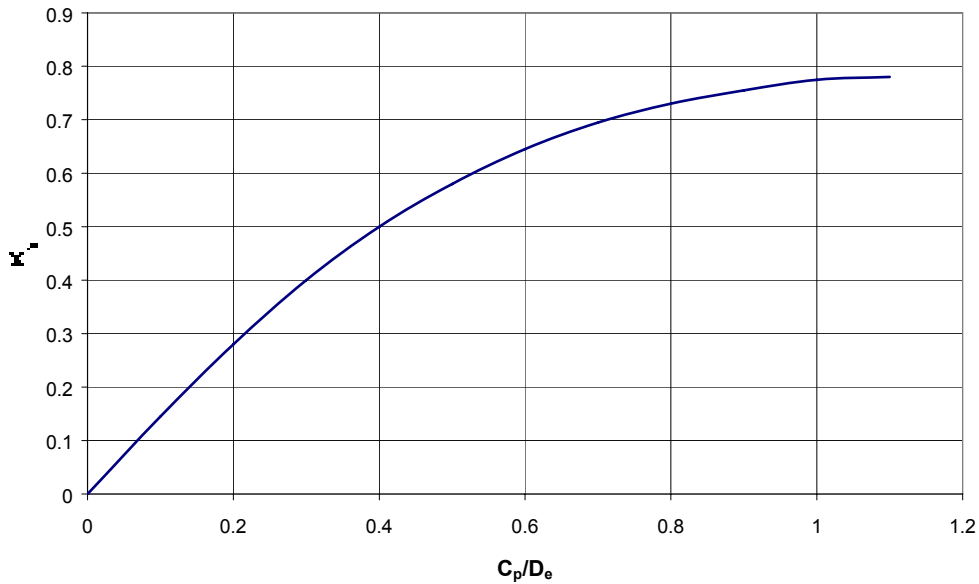


Figure 6.23: Nozzle characteristic

For the other dimension calculations, please refer to the De Siervo and Lugaresi article <sup>10</sup>.

*Francis turbines*

Francis turbines cover a wide range of specific speeds, going from 0.05 to 0.33 corresponding to high head and low head Francis respectively.

Figure 6.24 shows schematically a cross section of a Francis runner, with the reference diameters  $D_1$ ,  $D_2$  and  $D_3$ .

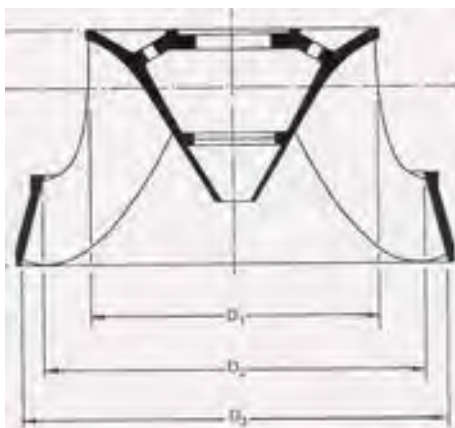


Figure 6.24: Cross section of a Francis Runner

The de Siervo and de Leva<sup>11</sup> and Lugaresi et Massa<sup>13</sup> articles, based on a statistical analysis of more than two hundred existing turbines, enables a preliminary design of the Francis Turbine. As with all statistical analysis, the results will not be sufficient on their own for complete turbine design. They only correspond to standard average solutions, particularly if we consider the cavitation criterion (see chapter 6.1.4.4).

The outlet diameter  $D_3$  is given by equation 6.20.

$$D_3 = 84.5 \cdot (0.31 + 2.488 \cdot n_{QE}) \cdot \frac{\sqrt{H_n}}{60 \cdot n} \quad [\text{m}] \quad (6.20)$$

The inlet diameter  $D_1$  is given by equation 6.21

$$D_1 = (0.4 + \frac{0.095}{n_{QE}}) \cdot D_3 \quad [\text{m}] \quad (6.21)$$

The inlet diameter  $D_2$  is given by equation 6.22 for  $n_{QE} > 0.164$

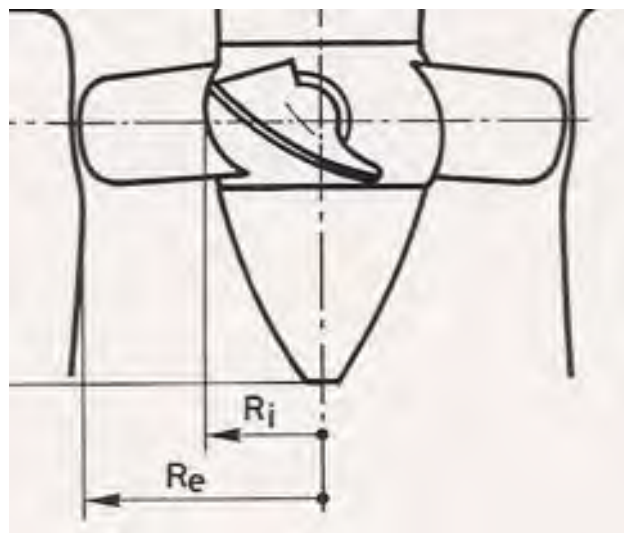
$$D_2 = \frac{D_3}{0.96 + 0.3781 \cdot n_{QE}} \quad [\text{m}] \quad (6.22)$$

For  $n_{QE} < 0.164$ , we can consider that  $D_1 = D_2$

For the other dimension calculations, please refer to the above-mentioned articles.

*Kaplan turbines*

The Kaplan turbines exhibit much higher specific speeds than Francis and Pelton.



**Figure 6.25: Cross section of a Kaplan turbine**

In the preliminary project phase the runner outer diameter  $D_e$  can be calculated by the equation 6.23.

$$D_e = 84.5 \cdot (0.79 + 1.602 \cdot n_{QE}) \cdot \frac{\sqrt{H_n}}{60 \cdot n} \quad [\text{m}] \quad (6.23)$$

The runner hub diameter  $D_i$  can be calculated by the equation 6.24.

$$D_i = (0.25 + \frac{0.0951}{n_{QE}}) \cdot D_e \quad [\text{m}] \quad (6.24)$$

For the other dimensions calculation, please refer to the De Siervo and De Leva<sup>12</sup> or Lugaresi and Massa<sup>14</sup> articles.

#### 6.2.4 Turbine selection criteria

The type, geometry and dimensions of the turbine will be fundamentally conditioned by the following criteria:

- Net head
- Range of discharges through the turbine
- Rotational speed
- Cavitation problems
- Cost

As previously expressed, the preliminary design and choice of a turbine are both iterative processes.

#### *Net head*

The gross head is well defined, as the vertical distance between the upstream water surface level at the intake and the downstream water level for reaction turbines or the nozzle axis level for impulse turbines.

As explained in chapter 6.1.1, equation 6.4, the net head is the ratio of the specific hydraulic energy of machine by the acceleration due to gravity. This definition is particularly important, as the remaining kinetic energy in low head schemes cannot be neglected.

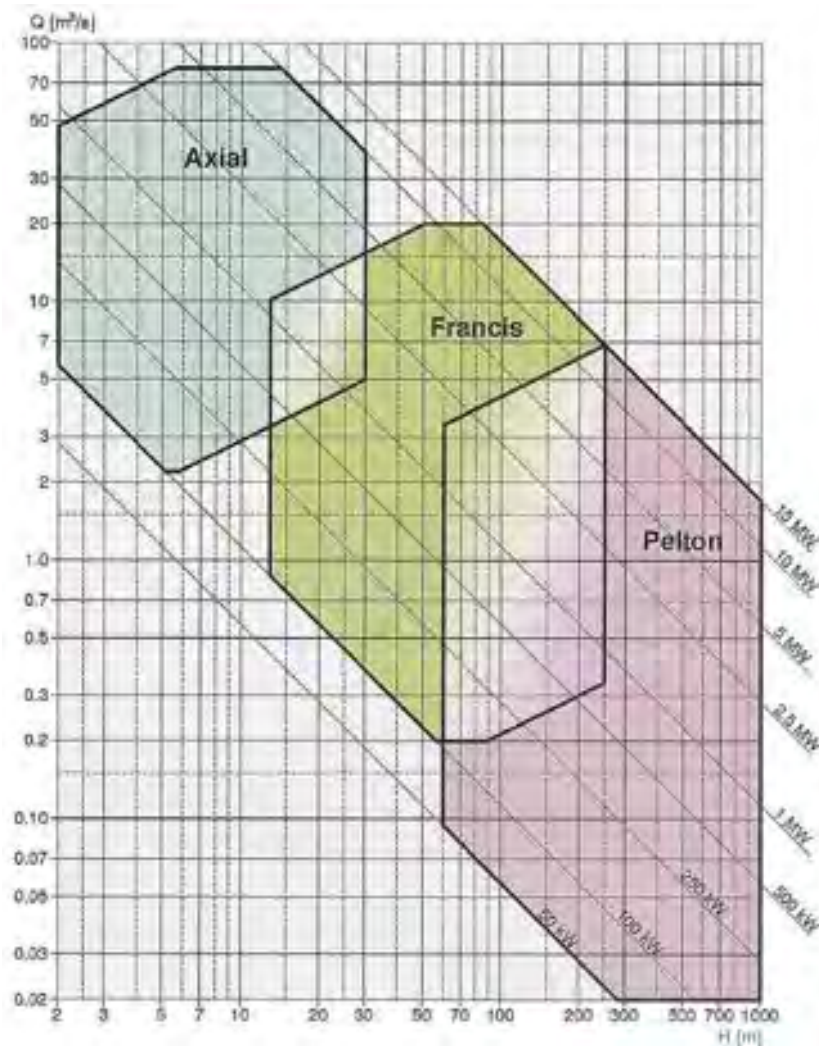
The first criterion to take into account in the turbine's selection is the net head. Table 6.3 specifies the range of operating heads for each type of turbine. The table shows some overlapping, as for a certain head several types of turbines can be used.

**Table 6.3: Range of heads**

Turbine type	Head range in metres
Kaplan and Propeller	$2 < H_n < 40$
Francis	$25 < H_n < 350$
Pelton	$50 < H_n < 1'300$
Crossflow	$5 < H_n < 200$
Turgo	$50 < H_n < 250$

*Discharge*

A single value of the flow has no significance. It is necessary to know the flow regime, commonly represented by the Flow Duration Curve (FDC) 12 as explained in chapter 3, sections 3.3 and 3.6.



**Figure 6.26: Turbines' type field of application.**

The rated flow and net head determine the set of turbine types applicable to the site and the flow environment. Suitable turbines are those for which the given rated flow and net head plot within the operational envelopes (figure 6.26). A point defined as above by the flow and the head will usually plot within several of these envelopes. All of those turbines are appropriate for the job, and it will be necessary to compute installed power and electricity output against costs before making a decision. It should be remembered that the envelopes vary from manufacturer to manufacturer and they should be considered only as a guide.

As a turbine can only accept discharges between the maximal and the practical minimum, it may be advantageous to install several smaller turbines instead of one large turbine. The turbines would be sequentially started, so that all of the turbines in operation, except one, will operate at their nominal discharges and therefore will have a high efficiency. Using two or three smaller turbines will mean a lower unit weight and volume and will facilitate transport and assembly on the site. Sharing the flow between two or more units will also allow for higher rotational speed, which will reduce the need for a speed increaser.

In case of strong flow variation in the range of medium head, a multi-jet Pelton with a low rotational speed will be preferred to a Francis turbine. A similar remark can also be made for Kaplan and Francis in low heads.

The final choice between one or more units or between one type of turbine or another will be the result of an iterative calculation taking into account the investment costs and the yearly production.

**Table 6.4: Flow and head variation acceptance**

<b>Turbine type</b>	<b>Acceptance of flow variation</b>	<b>Acceptance of head variation</b>
Pelton	High	Low
Francis	Medium	Low
Kaplan double regulated	High	High
Kaplan single regulated	High	Medium
Propeller	Low	Low

*Specific speed*

The specific speed constitutes a reliable criterion for the selection of the turbine, without any doubt more precise than the conventional enveloping curves, just mentioned.

If we wish to produce electricity in a scheme with 100-m net head and 0.9 m<sup>3</sup>/s, using a turbine directly coupled to a standard 1500-rpm generator we should begin by computing the specific speed according equation (6.5).

$$n_{QE} = 0.135$$



With this specific speed the only possible selection is a Francis turbine. Otherwise if we accept the possibility of using a lower speed, it could be possible to select, in addition to the Francis, a 4-nozzles Pelton with 600-rpm generator.

If we intend to install a turbine in a 400 m head, 0.42 m<sup>3</sup>/s scheme, directly coupled to a 1000-rpm generator, we will begin computing the specific speed:

$$n_{QE} = 0.022$$

Which indicates the 1 jet Pelton option, with a diameter  $D_1 = 0.815$  m according to equation (6.15).

A two or more jet Pelton would also be possible if required by a highly variable flow requiring a good efficiency at part load.

As previously explained, the Pelton turbines are generally defined by the  $D_1/B_2$  ratio rather than by the specific speed. As a general rule, this ratio has to be higher than 2.7. Such a ratio cannot be obtained without model laboratory developments.

*Cavitation*

When the hydrodynamic pressure in a liquid flow falls below the vapour pressure of the liquid, there is a formation of the vapour phase. This phenomenon induces the formation of small individual bubbles that are carried out of the low-pressure region by the flow and collapse in regions of higher pressure. The formation of these bubbles and their subsequent collapse gives rise to what is called cavitation. Experience shows that these collapsing bubbles create very high impulse pressures accompanied by substantial noise (in fact a turbine undergoing cavitation sounds as though gravel is passing through it). The repetitive action of such collapse in a reaction turbine close to the runner blades or hub for instance results in pitting of the material. With time this pitting degenerates into cracks formed between the pits, and the metal is snatched from the surface. In a relatively short time the turbine is severely damaged and will need to be shut-off and repaired - if possible.

However cavitation is not a fatality. Laboratory developments allow for a proper hydraulic design to be defined and the operating field of the turbines to be fixed, which can both help in avoiding this problem.

Cavitation is characterised by the cavitation coefficient  $\sigma$  (Thoma's coefficient) defined according to IEC 60193 standard as:

$$\sigma = \frac{NPSE}{gH_n} \quad [-] \quad (6.25)$$

Where NPSE is the net positive suction energy defined as:

$$NPSE = \frac{P_{atm} - P_v}{\rho} + \frac{V^2}{2} - gH_s \quad [-] \quad (6.26)$$

Where:	$P_{atm}$ = atmospheric pressure	[Pa]
	$P_v$ = water vapour pressure	[Pa]
	$\rho$ = water specific density	[kg/m <sup>3</sup> ]
	$g$ = acceleration due to gravity	[m/s <sup>2</sup> ]
	$V$ = outlet average velocity	
	$H_n$ = net head	[m]
	$H_s$ = suction head	[m]

To avoid cavitation, the turbine should be installed at least at the  $H_s$  as defined by equation (6.27).

$$H_s = \frac{P_{atm} - P_v}{\rho \cdot g} + \frac{V^2}{2 \cdot g} - \sigma \cdot H_n \quad [m] \quad (6.27)$$

A positive value of  $H_s$  means that the turbine runner is over the downstream level, a negative value that it is under the downstream level.

As a first approach, one can consider that  $V = 2$  m/s.

The Thoma's sigma is usually obtained by a model test, and it is a value furnished by the turbine manufacturer. The above-mentioned statistical studies also relate Thoma's sigma with the specific speed. These specify the equation giving  $\sigma$  as a function of  $n_{QE}$  for the Francis and Kaplan turbines:

$$\text{Francis} \quad \sigma = 1.2715 \cdot n_{QE}^{1.41} + \frac{V^2}{2 \cdot g \cdot H_n} \quad [-] \quad (6.28)$$

$$\text{Kaplan} \quad \sigma = 1.5241 \cdot n_{QE}^{1.46} + \frac{V^2}{2 \cdot g \cdot H_n} \quad [-] \quad (6.29)$$

It must be remarked that  $P_{atm}$  decreases with the altitude, from roughly 1.01 bar m at the sea level to 0.65 bar at 3000 m above sea level. So then a Francis turbine with a specific speed of 0.150, working under a 100 m head (with a corresponding  $\sigma = 0.090$ ), that is in a plant at sea level, will require a setting of

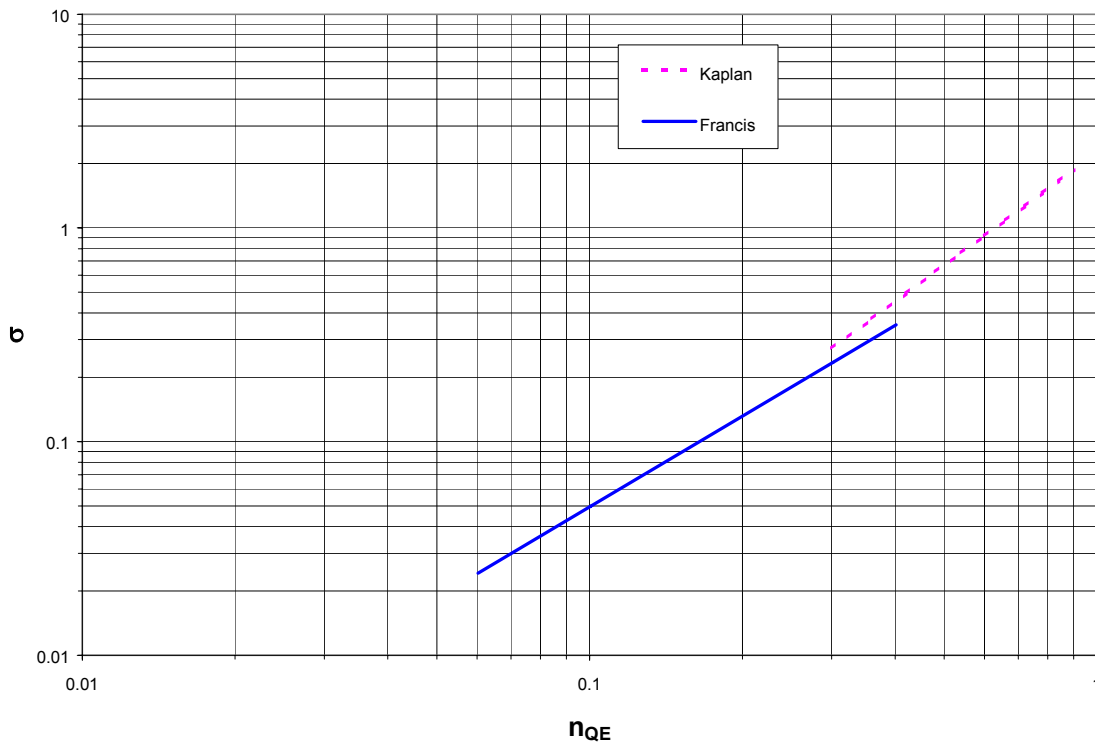
$$H_s = \frac{101'000 - 880}{1000 \cdot 9.81} + \frac{2^2}{2 \cdot 9.81} - 0.09 \cdot 100 = 1.41 \quad [m]$$

installed in a plant at 2000 m above the sea level will require

$$H_s = \frac{79'440 - 880}{1000 \cdot 9.81} + \frac{2^2}{2 \cdot 9.81} - 0.09 \cdot 100 = -0.79 \quad [m]$$

a setting requiring an excavation.

Figure 6.27 gives an overview of cavitation limits.



**Figure 6.27: Cavitation limits**

Equation 6.30 gives a mean to control the concordance between specific speed  $n_{QE}$  and cavitation limits.

$$n_{QE} \leq 0.686 \cdot \sigma^{0.5882} \quad [-] \quad (6.30)$$

It has to be noted that local cavitation can occur on Pelton buckets if the inlet edge is not properly designed or if the laboratory tested shape has not been fully respected during manufacture.

*Rotational speed*

According to equation 6.5 the rotational speed of a turbine is directly linked to its specific speed, flow and net head. In the small hydro schemes standard generators should be installed when possible, so in during turbine selection it must be considered that the generator, either coupled directly or through a speed increaser to the turbine, should reach the synchronous speed, as given in table 6.5.

**Table 6.5: Generator synchronisation speed**

Number of poles	Frequency		Number of poles	Frequency	
	50 Hz	60Hz		50 Hz	60 Hz
2	3000	3600	16	375	450
4	1500	1800	18	333	400
6	1000	1200	20	300	360
8	750	900	22	272	327
10	600	720	24	250	300
12	500	600	26	231	377
14	428	540	28	214	257

*Runaway speed*

Each runner profile is characterised by a maximum runaway speed. This is the speed, which the unit can theoretically attain in case of load rejection when the hydraulic power is at its maximum. Depending on the type of turbine, it can attain 2 or 3 times the nominal speed. Table 6.3 shows this ratio for miscellaneous turbines.

It must be remembered that the cost of both generator and eventual speed increaser may be increased when the runaway speed is higher, since they must be designed to withstand it.

**Table 6.6: Runaway speeds of turbines**

Turbine type	Runaway speed $n_{max}/n$
Kaplan single regulated	2.0 - 2.6
Kaplan double regulated	2.8 - 3.2
Francis	1.6 – 2.2
Pelton	1.8 – 1.9
Turgo	1.8 – 1.9

6.2.5 Turbine efficiency

It is really important to remember that the efficiency characterises not only the ability of a turbine to exploit a site in an optimal manner but also its hydrodynamic behaviour.

A very average efficiency means that the hydraulic design is not optimum and that some important problems may occur (as for instance cavitation, vibration, etc.) that can strongly reduce the yearly production and damage the turbine.

Each power plant operator should ask the manufacturer for an efficiency guarantee (not output guarantees) based on laboratory developments. It is the only way to get insurance that the turbine will work properly. The origin of the guarantees should be known, even for very small hydro turbines.

Figure 6.28 shows an example of a real site developed without efficiency guarantees and laboratory works.

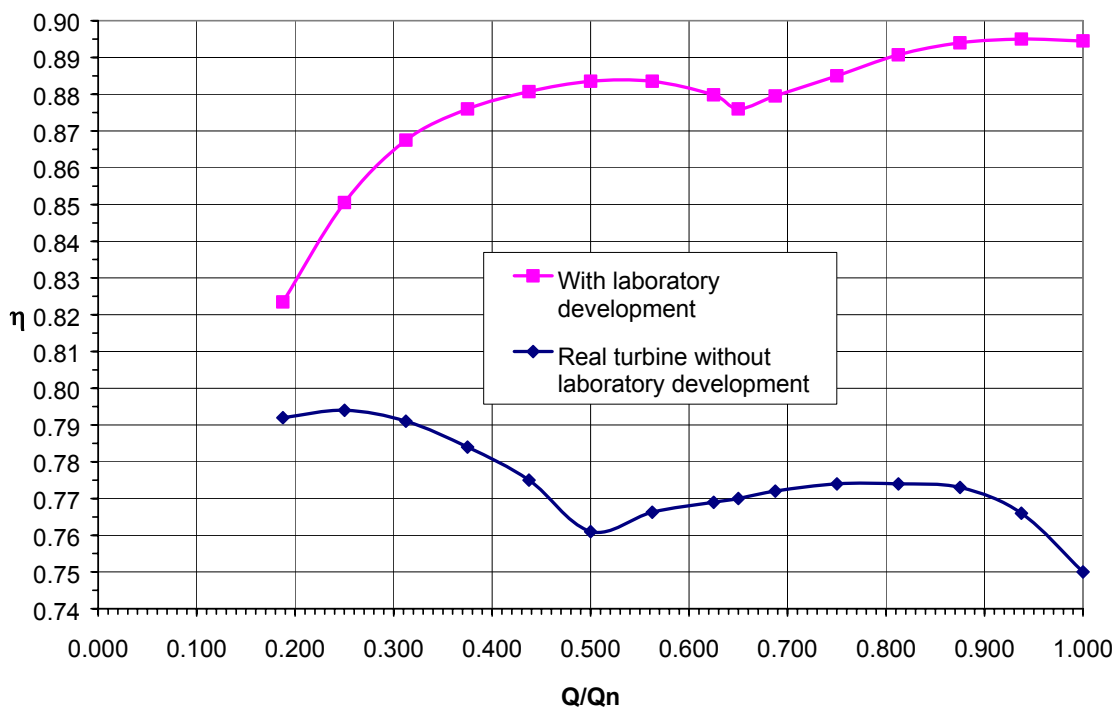


Figure 6.28: Efficiency measurement on a real turbine built without laboratory development.

For the owner who wishes to control the output of a turbine, two methods are available:

The first is to carry out **on site tests** after putting the turbine into service. In order to obtain adequate measurement precision, elaborate techniques, which are difficult to implement and which most often are not suitable for small installations must be used. It is therefore generally necessary to resort to simpler methods, the results of which are always questionable. If the tests demonstrate that guaranteed output is not achieved, it is usually too late to improve the machine. Payment, by the

manufacturer, of contractual penalties never usually compensates for the loss of production sustained by the operator, over the turbine's lifetime.

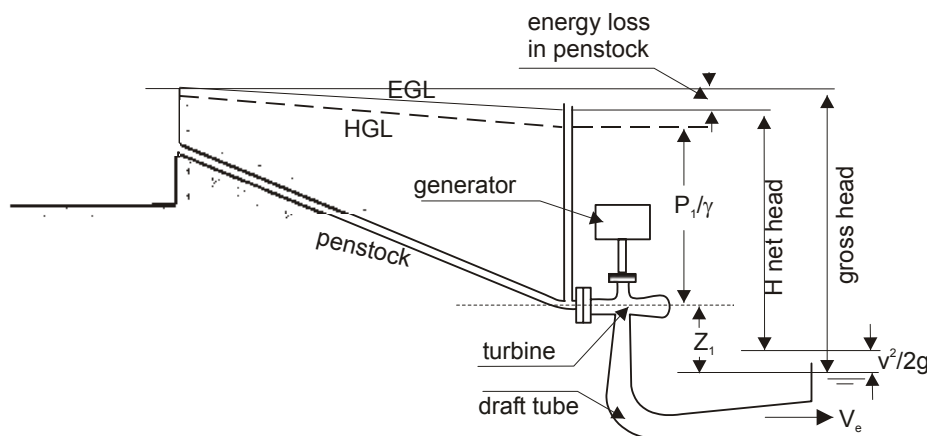
The second method consists of performing **laboratory tests** on turbines geometrically similar to the industrial prototypes. In the case of small hydropower plants, the size of the models being tested is often quite close to that of the actual machines. The hydraulic behaviour of the turbine may be observed over the whole extent of its operating range. It is thus possible to correct any possible shortcomings **before** the machine is actually built.

The efficiency guaranteed by turbine manufacturers is that which may be verified in accordance with the "International Code for the field acceptance tests of hydraulic turbines" (publication IEC 60041) or, if applied, in accordance with the "International Code for model acceptance tests" (publication IEC 60193). It is defined as the ratio of power supplied by the turbine (mechanical power transmitted by the turbine shaft) to the hydraulic power, as defined in equation 6.1.

$$\eta = \frac{P_{mec}}{P_h} \quad [-] \quad (6.31)$$

As defined in figure 6.29, the turbine is not only limited to the runner. International standards clearly define the limits of the turbine and the manufacturer must give its guarantees according to these limits. The manufacturer also indicates quality criterion that the owner has to respect, such as velocity repartition and flow deviation at the intake in the case of low head schemes.

It should be noted that for impulse turbines (Pelton and Turgo), the head is measured at the point of impact of the jet, which is always above the downstream water level. This effectively amounts to a reduction of the head. The difference is not negligible for medium-head schemes, when comparing the performance of impulse turbines with those of reaction turbines that use the entire available head.



**Figure 6.29: Schematic view of the energy losses in an hydro power scheme**

Due to the energy losses generated in reaction turbines the runner uses a lower energy than the specific hydraulic energy of the whole machine, as defined in figure 6.30. These losses are essentially friction losses in the spiral case, guide-vanes and runner blades plus kinetic remaining energy in the draft tube.

The draft-tube or diffuser is designed to recover the biggest possible fraction of the kinetic energy of the water leaving the blades. This remaining energy is particularly critical in the very low heads (< 5m), where it may reach up to 80% of the net head (whereas in the medium head it rarely exceeds 3%-4%). The draft-tube has such implications on the turbine operation and efficiency that only the turbine manufacturer can design it properly according to his laboratory developments.

Fig 6.30 (to be used with Table 6.7) indicates the typical efficiency guaranteed by manufacturers for several types of turbine. To estimate the overall efficiency the turbine efficiency must be multiplied by the efficiencies of the speed increaser (if used) and the alternator.

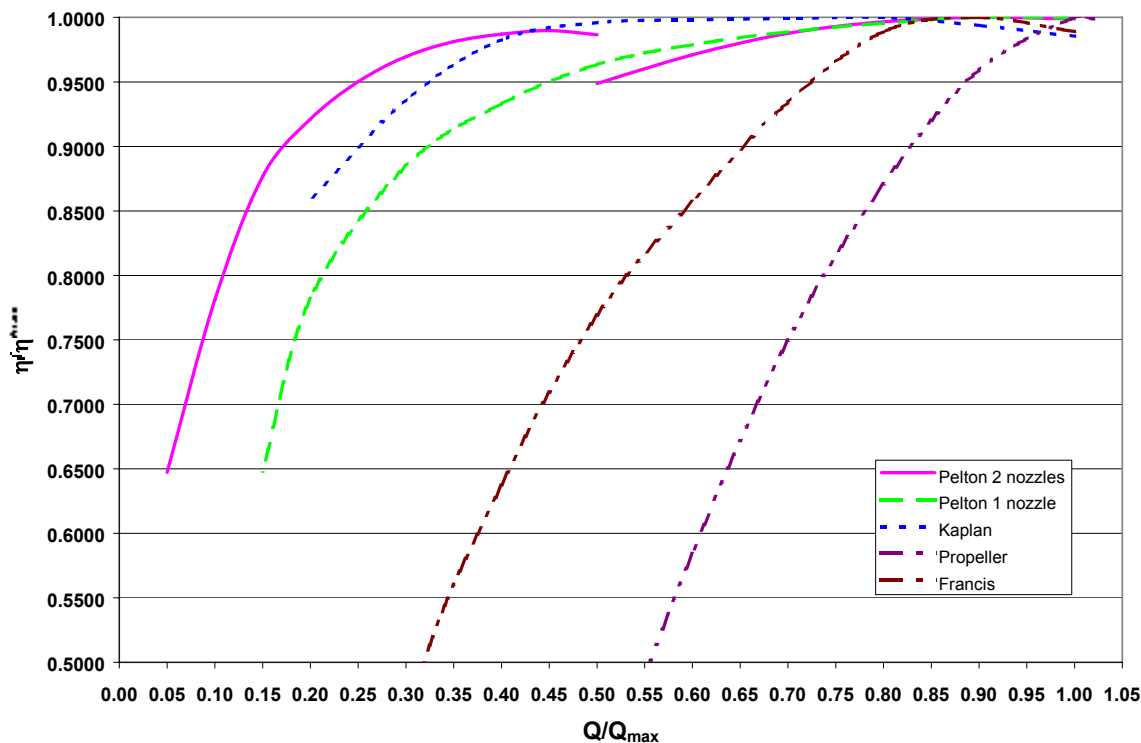


Figure 6.30: Typical small hydro turbines efficiencies

When the flow deviates from that nominal discharge so does the turbine's hydraulic efficiency. As the design discharge of reaction turbines is generally chosen to be different from the best efficiency discharge, the efficiencies given in table 6.7 correspond to best efficiency, but not to efficiency at design or maximum discharge.

Double regulated Kaplan and Pelton turbines can operate satisfactorily over a wide range of flow - upwards from about one fifth of rated discharge. Single regulated Kaplans have acceptable efficiency upward from one-third and Francis turbines from one half of rated discharge. Below 40% of the rated discharge, Francis turbines may show instability resulting in vibration or mechanical shock.

Propeller turbines with fixed guide vanes and blades can operate satisfactorily only over a very limited range close to their rated discharge. It should be noted that single-regulated Kaplan turbines are only efficient if it is the runner that is adjustable.

**Table 6.7: Typical efficiencies of small turbines**

Turbine type	Best efficiency
Kaplan single regulated	0.91
Kaplan double regulated	0.93
Francis	0.94
Pelton n nozzles	0.90
Pelton 1 nozzle	0.89
Turgo	0.85

### 6.3 Speed increasers

When the turbine and the generator operate at the same speed and can be placed so that their shafts are in line, direct coupling is the right solution; virtually no power losses are incurred and maintenance is minimal. Turbine manufactures will recommend the type of coupling to be used, either rigid or flexible although a flexible coupling that can tolerate certain misalignment is usually recommended.

In many instances, particularly in low head schemes, turbines run at less than 400 rpm, requiring a speed increaser to meet the 750-1000 rpm of standard alternators. In the range of powers contemplated in small hydro schemes this solution is often more economical than the use of a custom made alternator.

Nowadays alternator manufacturers also propose low speed machines allowing direct coupling.

#### 6.3.1 Speed increaser types

Speed increasers according to the gears used in their construction are classified as:

- Parallel-shaft using helical gears set on parallel axis and are especially attractive for medium power applications. Figure 6.31 shows a vertical configuration, coupled to a vertical Kaplan turbine.
- Bevel gears commonly limited to low power applications using spiral bevel gears for a 90° drive. Figure 6.32 shows a two-phased speed increaser. The first is a parallel gearbox and the second a bevel gear drive.
- Belt speed increaser that is commonly used for small power application and offer maintenance facilities (see figure 6.33).



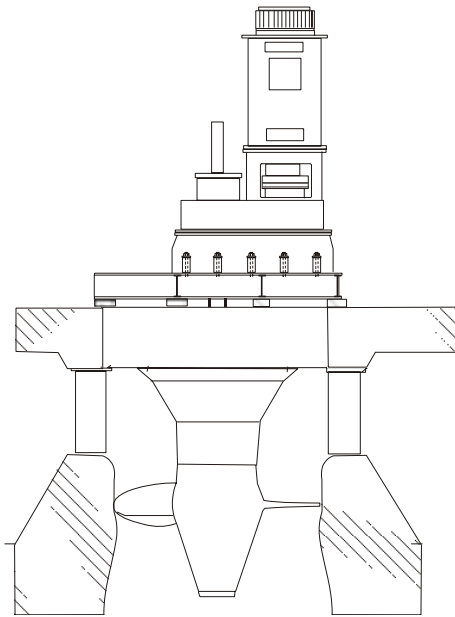


Figure 6.31: Parallel shaft speed increaser

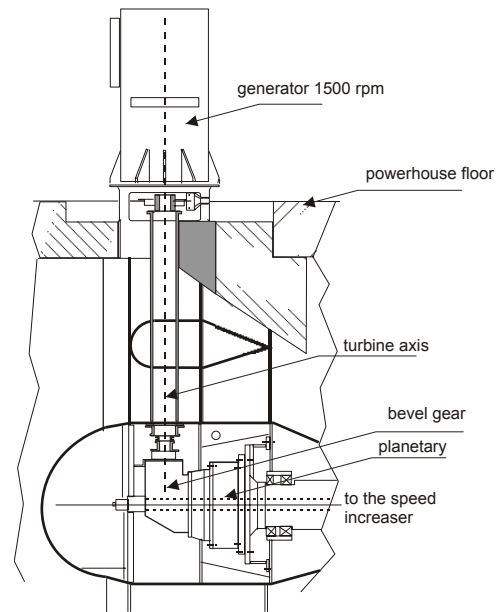


Figure 6.32: Bevel gear speed increaser

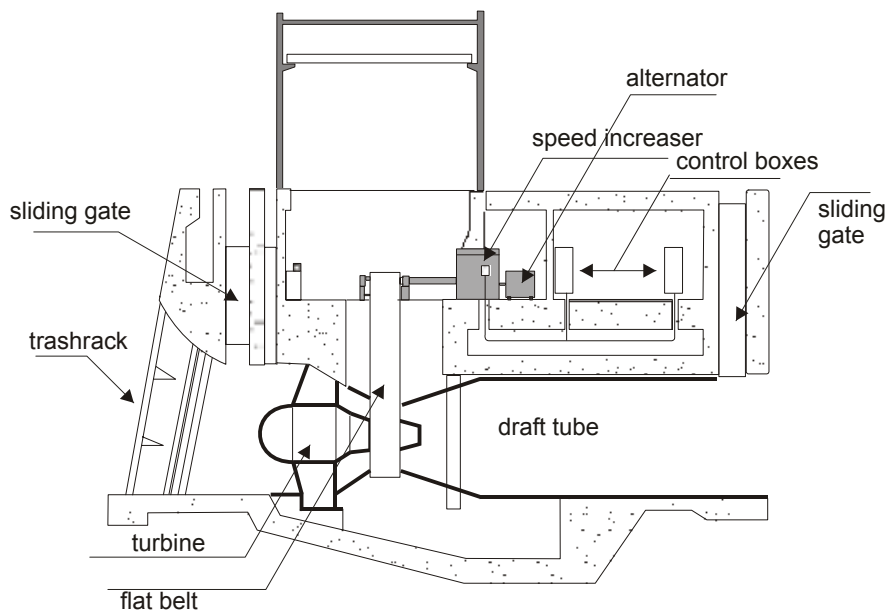


Figure 6.33: Belt speed increaser

### 6.3.2 Speed increaser design

The gearbox should be designed to ensure, under the most unfavourable conditions, the correct alignment of its components. They are usually fabricated in welded steel with heavy stiffeners to resist the turbine torque and hydraulic axial thrust without apparent deformation.

A lack of synchronism, full load rejection, or any other accident in the system can generate very high critical stresses on the gears. To protect gears against these exceptional strains the speed increaser should incorporate a torque limiter, so that the connector breaks when there is an abnormal force.

To ensure the required level of reliability good lubrication is essential. It is very important that the quality, volume, viscosity and temperature of the oil always stay within specifications. A double lubrication system with two pumps and two oil filters would contribute to the system reliability.

Speed increasers are designed according to international standards (AGMA 2001, B88 or DIN 3990) using very conservative design criteria. These criteria conflict with the need to reduce costs, but no cost savings are possible or recommended without a thorough analysis of the fatigue strains, and a careful shaving of the heat treated gears, a satisfactory stress relieving of the welded boxes, all of which are essential to ensure the durability of a speed increaser. Metallurgical factors including knowledge of the respective advantages and disadvantages of hard casing or nitriding of gears are also essential to optimise the speed increaser.

Selection of journal bearings is also crucial. Under 1 MW the use of roller bearings is usual. Nowadays manufacturers begin to use such technology for turbines up to 5 MW. The other possibility is to use hydrodynamic lubricated bearings that present the following advantages:

- The life of the roller bearings is limited by fatigue whereas the hydrodynamic bearings have a practically unlimited life.
- Hydrodynamic bearings permit a certain oil contamination, whereas roller bearings do not.

### 6.3.3 Speed increaser maintenance

At least 70% of speed increaser malfunctioning is due to the poor quality or the lack of the lubricant oil. Frequently the oil filters clog or water enters the lubrication circuit. Maintenance should be scheduled either based on predetermined periods of time or –better still by periodic analysis of the lubricant to check that it meets specifications.

Speed increasers substantially increase the noise in the powerhouse and require careful maintenance as their friction losses can exceed 2% of the outlet power, so other alternatives have been investigated, as for instance the use of low speed generators.

## 6.4 Generators

Generators transform mechanical energy into electrical energy. Although most early hydroelectric systems were of the direct current variety to match early commercial electrical systems, nowadays only three-phase alternating current generators are used in normal practice. Depending on the characteristics of the network supplied, the producer can choose between:

- **Synchronous generators:** They are equipped with a DC electric or permanent magnet excitation system (rotating or static) associated with a voltage regulator to control the output voltage before the generator is connected to the grid. They supply the reactive energy required by the power system when the generator is connected to the grid. Synchronous generators can run isolated from the grid and produce power since excitation is not grid-dependent

- **Asynchronous generators:** They are simple squirrel-cage induction motors with no possibility of voltage regulation and running at a speed directly related to system frequency. They draw their excitation current from the grid, absorbing reactive energy by their own magnetism. Adding a bank of capacitors can compensate for the absorbed reactive energy. They cannot generate when disconnected from the grid because are incapable of providing their own excitation current. However, they are used in very small stand-alone applications as a cheap solution when the required quality of the electricity supply is not very high.

Below 1 MW, synchronous generators are more expensive than asynchronous generators and are used in power systems where the output of the generator represents a substantial proportion of the power system load. Asynchronous generators are cheaper and are used in stable grids where their output is an insignificant proportion of the power system load. The efficiency should be 95 % for a 100 kW machine and can increase to 97% towards an output power of 1MW. Efficiencies of synchronous generators are slightly higher. In general, when the power exceeds some MVA a synchronous generator is installed.

Recently, variable-speed constant-frequency systems (VSG), in which turbine speed is permitted to fluctuate widely, while the voltage and frequency are kept constant and undistorted, have become available. The frequency converter, which is used to connect the generator via a DC link to the grid can even "synchronise" to the grid before the generator starts rotating. This approach is often proposed as a means of improving performance and reducing cost. However no cost reduction can be achieved using propeller turbines, if runner regulation is replaced only. It is also not possible, to improve the energy production compared to a double-regulated Kaplan turbine. There are nevertheless a number of cases where variable speed operation seems to be a suitable solution, e.g. when the head varies significantly.

The operating voltage of the generator increases with power. The standard generation voltages of 400 V or 690 V allow for the use of standard distributor transformers as outlet transformers and the use of the generated current to feed into the plant power system. Generators of some MVA are usually designed for higher operating voltages up to some kV and connected to the grid using a customised transformer. In this case an independent transformer HT/LT is necessary for the auxiliary power supply of the power plant.

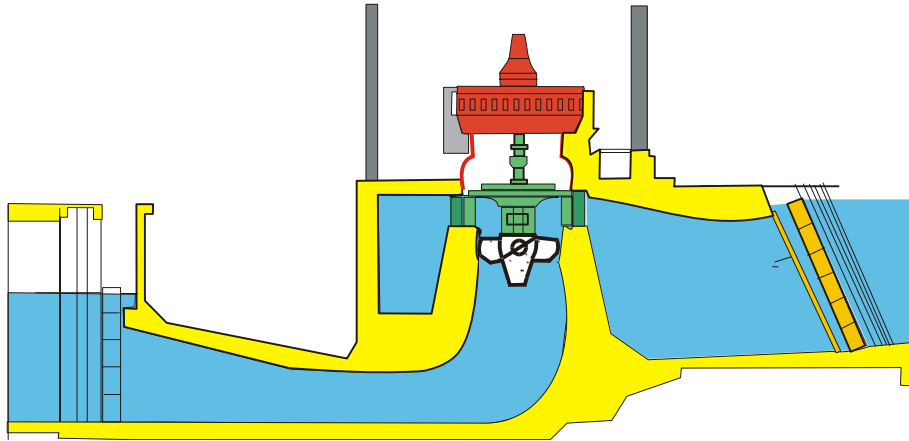
**Table 6.8: Typical efficiencies of small generators**

Rated power [kW]	Best efficiency
10	0.910
50	0.940
100	0.950
250	0.955
500	0.960
1000	0.970

### 6.4.1 Generator configurations

Generators can be manufactured with horizontal or vertical axis, independently of the turbine configuration. Figure 6.34 shows a vertical axis Kaplan turbine turning at 214 rpm directly coupled to a custom made 28 poles alternator.

A flywheel is frequently used to smooth-out speed variations and assists the turbine control.



**Figure 6.34: Vertical axis generator directly coupled to a Kaplan turbine**

Another criterion for characterising generators is how their bearings are positioned. For example it is common practice to install a generator with extra-reinforced bearings supporting the cantilevered runner of a Francis turbine. In that way the turbine axis does not need to cross the draft tube so improving the overall efficiency. The same solution is frequently used with Pelton turbines.

When these generators are small, they have an open cooling system, but for larger units it is recommended that a closed cooling circuit provided with air-water heat exchangers.

### 6.4.2 Exciters

The exciting current for the synchronous generator can be supplied by a small DC generator, known as the exciter, driven from the main shaft. The power absorbed by this DC generator amounts to 0.5% - 1.0% of the total generator power. Nowadays a static exciter usually replaces the DC generator, but there are still many rotating exciters in operation.

#### Rotating exciters.

The field coils of both the main generator and the exciter generator are usually mounted on the main shaft. In larger generators a pilot exciter with permanent magnet excitation is also used. It supplies the exciting current to the main exciter, which in turn supplies the exciting current for the rotor of the generator.

### Brushless exciters

A small generator has its field coils on the stator and generates AC current in the rotor windings. A solid state rectifier rotates with the shaft, converting the AC output from the small generator into the DC, which is supplied to the rotating field coils of the main generator without the need for brushes. The voltage regulation is achieved by controlling the current in the field coils of the small generator.

### Static exciters

A static exciter is a grid connected rectifier that provides DC current to the generator field coils instead of the rotating exciter. The voltage and power factor control works in the same way as with the rotating device. Static exciters are robust, easy to maintain and have a high efficiency. The response to the generator voltage oscillations is very good.

## 6.4.3 Voltage regulation and synchronisation

### Asynchronous generators

An asynchronous generator needs to absorb reactive power from the three-phase mains supply to ensure its magnetisation is even. The mains supply defines the frequency of the stator rotating flux and hence the synchronous speed above which the rotor shaft must be driven.

On start-up, the turbine is accelerated to a speed slightly above the synchronous speed of the generator, when a velocity relay closes the main line switch. From this hyper-synchronised state the generator speed will be reduced to synchronous speed by feeding current into the grid. Speed deviations from synchronous speed will generate a driving or resisting torque that balances in the area of stable operation.

### Synchronous generators

The synchronous generator is started before connecting it to the mains by the turbine rotation. By gradually accelerating the turbine, the generator must be synchronised with the mains, regulating the voltage, frequency, phase angle and rotating sense. When all these values are controlled correctly, the generator can be switched to the grid. In the case of an isolated or off grid operation, the voltage controller maintains a predefined constant voltage, independent of the load. In case of the mains supply, the controller maintains the predefined power factor or reactive power.

## **6.5 Turbine control**

Turbines are designed for a certain net head and discharge. Any deviation from these parameters must be compensated for by opening or closing the control devices, such as the wicket-gates, vanes, spear nozzles or valves, to keep either the outlet power, the level of the water surface in the intake, or the turbine discharge constant.

In schemes connected to an isolated network, the parameter that needs to be controlled is the turbine speed, which controls the frequency. In an off grid system, if the generator becomes overloaded the turbine slows-down therefore an increase of the flow of water is needed to ensure the turbine does not stall. If there is not enough water to do this then either some of the load must be removed or the turbine will have to be shut down. Conversely if the load decreases then the flow to the turbine is

decreased or it can be kept constant and the extra energy can be dumped into an electric ballast load connected to the generator terminals.

In the first approach, speed (frequency) regulation is normally accomplished through flow control; once a gate opening is calculated, the actuator gives the necessary instruction to the servomotor, which results in an extension or retraction of the servo's rod. To ensure that the rod actually reaches the calculated position, feedback is provided to the electronic actuator. These devices are called "speed governors".

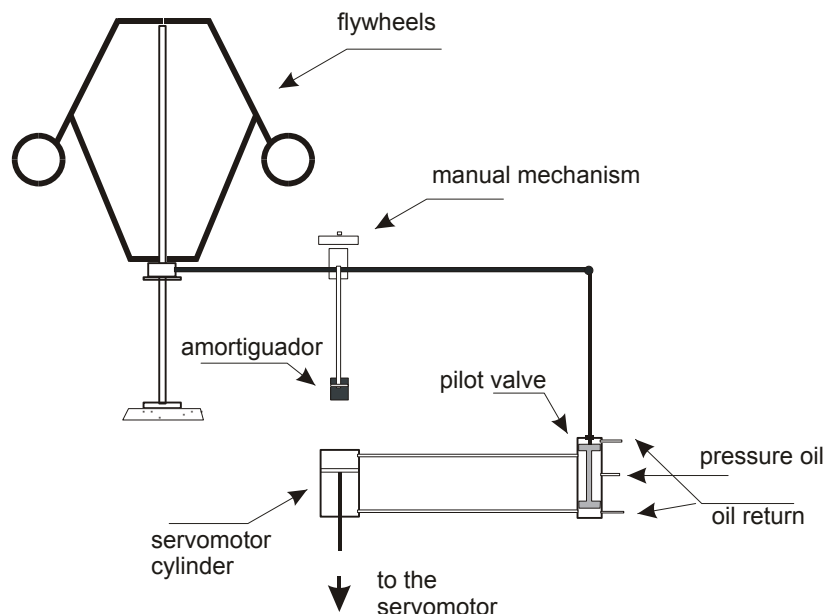
In the second approach it is assumed that, at full load, constant head and flow, the turbine will operate at design speed, so maintaining full load from the generator; this will run at a constant speed. If the load decreases the turbine will tend to increase its speed. An electronic sensor, measuring the frequency, detects the deviation and a reliable and inexpensive electronic load governor, switches on pre-set resistance and so maintains the system frequency accurately.

The controllers that follow the first approach do not have any power limit. The Electronic Load Governors, working according to the second approach rarely exceed 100 kW capacity.

Speed Governors

A governor is a combination of devices and mechanisms, which detect speed deviation and convert it into a change in servomotor position. A speed-sensing element detects the deviation from the set point; this deviation signal is converted and amplified to excite an actuator, hydraulic or electric, that controls the water flow to the turbine. In a Francis turbine, where there is a reduction in water flow you need to rotate the wicket-gates. For this, a powerful governor is required to overcome the hydraulic and frictional forces and to maintain the wicket-gates in a partially closed position or to close them completely.

Several types of governors are available varying from old fashioned purely mechanical to mechanical-hydraulic to electrical-hydraulic and mechanical-electrical. The purely mechanical governor is used with fairly small turbines, because its control valve is easy to operate and does not require a big effort. These governors use a flyball mass mechanism driven by the turbine shaft. The output from this device - the flyball axis descends or ascends according to the turbine speed - directly drives the valve located at the entrance to the turbine.



**Figure 6.35: mechanical speed governor**

In the past, the most commonly used type was the oil-pressure governor (Fig 6.35) that also uses a flyball mechanism, which is lighter and more precise than that used in a purely mechanical governor. When the turbine is overloaded, the flyballs slowdown, the balls drop, and the sleeve of the pilot valve rises to open access to the upper chamber of the servomotor. The oil under pressure enters the upper chamber of the servomotor to rotate the wicket-gates mechanism, increase the flow, and consequently the rotational speed and the frequency.

In a modern electrical-hydraulic governor a sensor located on the generator shaft continuously senses the turbine speed. The input is fed into a summing junction, where it is compared to a speed reference. If the speed sensor signal differs from the reference signal, it emits an error signal (positive or negative) that, once amplified, is sent to the servomotor so this can act in the required sense. In general the actuator is powered by a hydraulic power unit (photo 6.10) consisting of a sump for oil storage, an electric motor operated pump to supply high pressure oil to the system, an accumulator where the oil under pressure is stored, oil control valves and a hydraulic cylinder. All these regulation systems, as have been described, operate by continuously adjusting the wicket-gates position back and forth. To provide quick and stable adjustment of the wicket-gates, and/or of the runner blades, with the least amount of over or under speed deviations during system changes a further device is needed. In oil pressure governors, as may be seen in figure 6.37, this is achieved by interposing a "dash pot" that delays the opening of the pilot valve. In electrical-hydraulic governors the degree of sophistication is much greater, so that the adjustment can be proportional, integral and derivative (PID) giving a minimum variation in the controlling process.

An asynchronous generator connected to a stable electric grid, does not need any controller, because its frequency is controlled by the mains. Notwithstanding this, when the generator is disconnected from the mains the turbine accelerates up to runaway speed of the turbine. Generator and speed increaser have to be designed to withstand this speed long enough until the water flow is closed by the controlling system (guide vanes or valve).

To ensure the control of the turbine speed by regulating the water flow, certain inertia of the rotating components is required. Additional inertia can be provided by a flywheel, on the turbine, or the generator shaft. When the main switch disconnects the generator, the power excess accelerates the flywheel; later, when the switch reconnects the load, the deceleration of this inertia flywheel supplies additional power that helps to minimise speed variation. The basic equation of the rotating system is the following:

$$J \cdot \frac{d\Omega}{dt} = T_t - T_L \quad [\text{Nm}] \quad (6.32)$$

where:	J = moment of inertia of the rotating components	[kg m <sup>2</sup> ]
	Ω = angular velocity	[rad/s]
	T <sub>t</sub> = torque of turbine	[Nm]
	T <sub>L</sub> = torque due to load	[Nm]

When T<sub>t</sub> is equal to T<sub>L</sub>, d Ω /dt = 0 and Ω = constant, so the operation is steady. When T<sub>t</sub> is greater or smaller than T<sub>L</sub>, Ω is not constant and the governor must intervene so that the turbine output

matches the generator load. But it should not be forgotten that the control of the water flow introduces a new factor: the speed variations on the water column formed by the waterways.

The flywheel effect of the rotating components is stabilising whereas the water column effect is destabilising. The start-up time of the rotating system, the time required to accelerate the unit from zero rotational speed to operating speed is given by

$$t_m = J \frac{\Omega^2}{P} = \frac{\Omega \cdot R^2 \cdot n^2}{5086 \cdot P} \quad [s] \quad (6.33)$$

where the rotating inertia of the unit is given by the weight of all rotating parts multiplied by the square of the radius of gyration:  $\Omega R^2$ , P is the rated power in kW and n the turbine speed (rpm)

The water starting time, needed to accelerate the water column from zero velocity to some other velocity V, at a constant specific hydraulic energy gH is given by:

$$t_v = \frac{\sum L \cdot V}{gH} \quad [s] \quad (6.34)$$

where	gH = specific hydraulic energy of the turbine	[J/kg]
	L = length of water column	[m]
	V = velocity of the water	[m/s]

To achieve good regulation, it is necessary that  $T_m/T_w > 4$ . Realistic water starting times do not exceed 2.5 sec. If it is larger, modification of the water conduits must be considered - either by decreasing the velocity or the length of the conduits by installing a surge tank. The possibility of adding a flywheel to the generator to increase the inertia rotating parts can also be considered. It should be noted that an increase in the inertia of the rotating parts would improve the waterhammer effect and decrease the runaway speed.

## **6.6 Switchgear equipment**

In many countries the electricity supply regulations place a statutory obligation on the electric utilities to maintain the safety and quality of electricity supply within defined limits. The independent producer must operate his plant in such a way that the utility is able to fulfil its obligations. Therefore various associated electrical devices are required inside the powerhouse for the safety and protection of the equipment.

Switchgear must be installed to control the generators and to interface them with the grid or with an isolated load. It must provide protection for the generators, main transformer and station service transformer. The generator breaker, either air, magnetic or vacuum operated, is used to connect or disconnect the generator from the power grid. Instrument transformers, both power transformers (PTs) and current transformers (CTs) are used to transform high voltages and currents down to more manageable levels for metering. The generator control equipment is used to control the generator voltage, power factor and circuit breakers.



The asynchronous generator protection must include, among other devices: a reverse-power relay giving protection against motoring; differential current relays against internal faults in the generator stator winding; a ground-fault relay providing system backup as well as generator ground-fault protection, etc. The power transformer protection includes an instantaneous over-current relay and a timed over-current relay to protect the main transformer when a fault is detected in the bus system or an internal fault in the main power transformer occurs.

The independent producer is responsible for earthing arrangements within his installation. This must be designed in agreement with the public utility. The earthing arrangement will be dependent on the number of units in use and the independent producer's own system configuration and method of operation.

Metering equipment must be installed at the point of supply to record measurements according to the requirements of the electric utility.

Figure 6.38 shows a single-line diagram corresponding to a power plant with a single unit. In the high voltage side there is a line circuit breaker and a line disconnection switch - combined with a grounding switch - to disconnect the power generating unit and main transformer from the transmission line. Metering is achieved through the corresponding P.T and C.T. A generator circuit breaker is included as an extra protection for the generator unit. A transformer provides energy for the operation of intake gates, shutoff valves, servomotors, oil compressors etc. in the station service.

Greater complexity may be expected in multiunit stations where flexibility and continuity of service are important.

## **6.7 Automatic control**

Small hydro schemes are normally unattended and operated through an automatic control system. Because not all power plants are alike, it is almost impossible to determine the extent of automation that should be included in a given system, but some requirements are of general application:

- a) The system must include the necessary relays and devices to detect malfunctioning of a serious nature and then act to bring the unit or the entire plant to a safe de-energised condition.
- b) Relevant operational data of the plant should be collected and made readily available for making operating decisions, and stored in a database for later evaluation of plant performance.
- c) An intelligent control system should be included to allow for full plant operation in an unattended environment.
- d) It must be possible to access the control system from a remote location and override any automatic decisions.
- e) The system should be able to communicate with similar units, up and downstream, for the purpose of optimising operating procedures.
- f) Fault anticipation constitutes an enhancement to the control system. Using an expert system, fed with baseline operational data, it is possible to anticipate faults before they occur and take corrective action so that the fault does not occur.

The system must be configured by modules. An analogue-to-digital conversion module for measurement of water level, wicket-gate position, blade angles, instantaneous power output, temperatures, etc. A digital-to-analogue converter module to drive hydraulic valves, chart recorders, etc. A counter module to count generated kWh pulses, rain gauge pulses, flow pulses, etc. and a "smart" telemetry module providing the interface for offsite communications, via dial-up telephone lines, radio link or other communication technologies. This modular system approach is well suited to the widely varying requirements encountered in hydropower control, and permits both hardware and software to be standardised. Cost reduction can be realised through the use of a standard system and modular software allows for easy maintenance.

Automatic control systems can significantly reduce the cost of energy production by reducing maintenance and increasing reliability, while running the turbines more efficiently and producing more energy from the available water.

With the tremendous development of desktop computers, their prices are now very low. Many manufacturers supply standardised data acquisition systems. New and cheap peripheral equipment, easily connected to a portable computers, are the "watch-dogs"- helping to monitor and replace control equipment in the event of failure is available and easy to integrate at low price. Improved graphic programming techniques assist the development of easy to use software with graphic user interfaces. Due to the rapid development of digital technologies, the differences between hardware platforms such as PLCs, micro-controllers and industry PCs, disappear for the operator.

## **6.8 Ancillary electrical equipment**

### **6.8.1 Plant service transformer**

Electrical consumption including lighting and station mechanical auxiliaries may require from 1 to 3 percent of the plant capacity; the higher percentage applies to micro hydro (less than 500 kW). The service transformer must be designed to take these intermittent loads into account. If possible, two alternative supplies, with automatic changeover, should be used to ensure service in an unattended plant.

### **6.8.2 DC control power supply**

It is generally recommended that remotely controlled plants are equipped with an emergency 24 V DC back-up power supply from a battery in order to allow plant control for shutdown after a grid failure and communication with the system at any time. The ampere-hour capacity must be such that, on loss of charging current, full control is ensured for as long as it may be required to take corrective action.

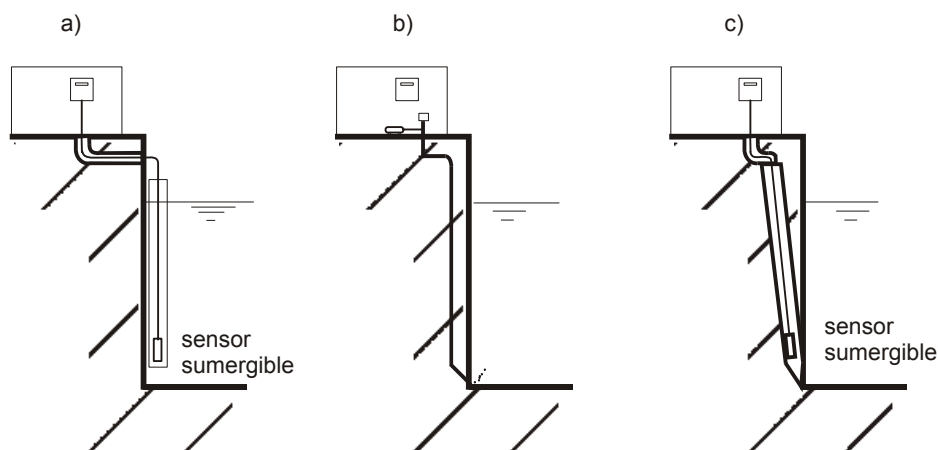
### **6.8.3 Headwater and tailwater recorders**

In a hydro plant, provisions should be made to record both the headwater and tailwater. The simplest way is to fix, securely in the stream, a board marked with meters and centimetres in the style of a levelling staff, however someone must physically observe and record the measurements. In powerhouses provided with automatic control the best solution is to use transducers connected to the computer via the data acquisition equipment.

Nowadays measuring units - a sensor - records the measurement variable and converts it into a signal that is transmitted to the processing unit. The measurement sensor must always be installed at the measurement site, where the level has to be measured. - Usually subject to rough environmental

conditions and of difficult access - whereas the processing unit is usually separated and placed in a well protected environment easily accessible for operation and service.

There is a wide range of sensors each one using a variety of measuring principles. It must be realised that the point of the level measurement needs to be selected carefully in order to represent the whole forebay. According to the Bernoulli principle, a change in the current speed causes a change in the dynamic pressure and consequently in the apparent water level as measured by the pressure sensor. If the measurement site is located in the inflow or outflow structures, where high current velocities can occur, the measurement will give false results. The level sensor can transmit the signal by using the hydrostatic method (figure 6.36 a) or the pneumatic (bubble) method (figure 6.36 b). In the first method care should be taken so that all the tubes for pressure transmission are dimensioned and laid in such a way that they cannot be obstructed nor air allowed accumulating within them. In the second, the sensor orifice is located lower than the corresponding level at the start of the measurement, and no water can penetrate and collect in the lines. In the solution shown in figure 6.36 a), floating material can damage the instrument. The best solution is the concealed assembly of all parts together within the wall as shown in figure 6.36 b) and c).



**Figure 6.36 Level measurement**

#### 6.8.4 Outdoor substation

The so-called water-to-wire system usually includes the substation. A line breaker must separate the plant including the step-up transformer from the grid in case of faults in the power plant. PTs and CTs for kWh and kW metering are normally mounted at the substation, at the connecting link between the plant-out conductors and the take-off line to the grid. In areas with very high environmental sensitivity the substation is enclosed in the powerhouse, and the transmission cables, leave it along the penstock. Lightning arresters for protection against line surges or lightning strikes in the nearby grid are usually mounted in the substation structure.

## 6.9 Examples

The following example will help in understanding the concepts exposed in this chapter and particularly the use of the specific speed tool.

Selecting a turbine to equip a 200-m net head scheme with a nominal flow of 1.5 m<sup>3</sup>/sec. The powerhouse is located at an altitude of 1000 m over the sea level.

According to table 6.3 or to figure 6.26 the plot of head and flow falls into the envelopes of a Francis and a Pelton turbine. The turbine speed is given as a function of  $n_{QE}$  by equation 6.5:

$$n = \frac{n_{QE} \cdot E^{\frac{3}{4}}}{\sqrt{Q}} = \frac{n_{QE} \cdot (9.81 \cdot 200)^{\frac{3}{4}}}{\sqrt{1.5}} = 240.7 \cdot n_{QE} \quad [\text{t/s}]$$

If we select a **one nozzle Pelton**, the maximum value for  $n_{QE}$  according to table 6.2, will be 0.025. The corresponding rotational speed would be 6 t/s = 360 t/min.

As we intend to use direct coupling, the rotational speed has to be synchronous, according to table 6.5. In this case, we would be obliged to choose a 333 t/min rotational speed (5.55 t/s = 34.87 rad/s).

According to 6.5, the corresponding  $n_{QE}$  would be:

$$n_{QE} = \frac{n \cdot \sqrt{Q}}{E^{\frac{3}{4}}} = \frac{5.55 \cdot \sqrt{1.5}}{(9.81 \cdot 200)^{\frac{3}{4}}} = 0.023 \quad [-]$$

The main Pelton dimensions according to 6.16, 6.17 and 6.18 would be:

$$D_1 = 0.68 \cdot \frac{\sqrt{H_n}}{n} = 0.68 \cdot \frac{\sqrt{200}}{5.55} = 1.733 \quad [\text{m}]$$

$$B_2 = 1.68 \cdot \frac{Q}{n_{jet} \cdot \sqrt{H_n}} = 1.68 \cdot \frac{1.5}{1 \cdot \sqrt{200}} = 0.547 \quad [\text{m}]$$

$$D_e = 1.178 \cdot \frac{Q}{n_{jet} \cdot \sqrt{gH}} = 1.178 \cdot \frac{1.5}{1 \cdot \sqrt{9.81 \cdot 200}} = 0.217 \quad [\text{m}]$$

Quite huge dimensions are not very realistic from an economical point of view.

If we now consider a **4-nozzle Pelton**, the maximum specific speed (according to table 6.2) would be

$$n_{QE} \leq 0.025 \cdot 4^{0.5} = 0.025 \cdot 2 = 0.050$$

Using the same calculation as for the one nozzle option, the rotational speed would be 600 rpm and the corresponding  $n_{QE}$  would be 0.042.

The main Pelton dimensions would be  $D_1 = 0.962$  m,  $B_2 = 0.274$  m and  $D_e = 0.108$  m which are quite reasonable.

If we now select a **Francis turbine**, the maximum value of  $n_{QE}$  would be 0.33 (table 6.2). Using equation 6.5, the corresponding speed would be  $n = 76.43$  t/s or 4'765.8 rpm, which is far from a realistic synchronous rotational speed. For this reason, we will choose the maximum usual value, which is 1,500 rpm.

According to 6.5, the corresponding  $n_{QE}$  would be:

$$n_{QE} = \frac{n \cdot \sqrt{Q}}{E^{\frac{3}{4}}} = \frac{25 \cdot \sqrt{1.5}}{(9.81 \cdot 200)^{\frac{3}{4}}} = 0.104 \quad [-]$$

The main Francis runner dimensions according to 6.20, 6.21 and 6.22 would be:

$$D_3 = 84.5 \cdot (0.31 + 2.488 \cdot n_{QE}) \cdot \frac{\sqrt{H_n}}{60 \cdot n} = 84.5 \cdot (0.31 + 2.488 \cdot 0.104) \cdot \frac{\sqrt{200}}{60 \cdot 25} = 0.453 \quad [m]$$

$$D_1 = \left(0.4 + \frac{0.0950}{n_{QE}}\right) \cdot D_3 = \left(0.4 + \frac{0.0950}{0.104}\right) \cdot 0.453 = 0.595 \quad [m]$$

As  $n_{QE} < 0.164$ , we can consider than  $D_2 = D_1 = 0.595$  m.

According to equation 6.28, the cavitation coefficient would be:

$$\sigma = 1.2715 \cdot n_{QE}^{1.41} + \frac{V^2}{2 \cdot g \cdot H_n} = 1.2715 \cdot 0.104^{1.41} + \frac{2^2}{2 \cdot 9.81 \cdot 200} = 0.0533 \quad [-]$$

According to equation 6.27, the setting would be:

$$H_s = \frac{P_{atm} - P_v}{\rho \cdot g} + \frac{V^2}{2 \cdot g} - \sigma \cdot H_n = \frac{90'250 - 880}{1'000 \cdot 9.81} + \frac{2^2}{2 \cdot 9.81} - 0.0533 \cdot 200 = -1.35 \quad [m]$$

A setting that requires important excavation.

If we have selected a Francis running at 1000 rpm we would have had:

$n_{QE} = 0.069$ ,  $D_3 = 0.576$  m,  $D_1 = 1.02$  m,  $\sigma = 0.0305$  and  $H_s = 3.21$  m which does not need excavation.

The final choice will be economical. If the flow strongly varies, a 4-nozzle Pelton could be a good choice. If it is not the case, a 1000-rpm Francis that does not need any excavation could be the best alternative.

<sup>1</sup> By Vincent Denis (MHyLab), Jean-Pierre Corbet (SCPTH), Jochen Bard (ISET), Jacques Fonkenell (SCPTH) and Celso Penche (ESHA)

<sup>2</sup> L. Vivier, "Turbines hydrauliques et leur régulation", Albin Michel, Paris, 1966

- <sup>3</sup> J. Raabe, *Hydro Power, The design, use and function of hydromechanical, hydraulic and electrical equipment*, VDI Verlag, 1985, ISBN 3-18-400616-6
- <sup>4</sup> T. Jacob, "Machines hydrauliques et équipements électro-mécaniques", EPFL 2002
- <sup>5</sup> V. Denis, "Petites centrales hydrauliques", EPFL 2002
- <sup>6</sup> Off. fédéral des questions conjoncturelles, "Turbines hydrauliques", Bern, 1995, ISBN 3-905232-54-5
- <sup>7</sup> Off. fédéral des questions conjoncturelles, "Générateurs et installations électriques", Bern, 1995, ISBN 3-905232-55-3
- <sup>8</sup> Off. fédéral des questions conjoncturelles, "Régulation et sécurité d'exploitation", Bern, 1995, ISBN 3-905232-56-1
- <sup>9</sup> A. Harvey, "Micro Hydro design manual, A guide to small scale water power schemes", Intermediate technology Publications, London, 1993, ISBN 1-85339-103-4
- <sup>10</sup> Société Hydrotechnique de France, "Design, construction, commissioning and operation Guide", May 1985
- <sup>11</sup> F. de Siervo & A. Lugaresi, "Modern trends in selecting and designing Pelton turbines", *Water Power & Dam Construction*, December 1978
- <sup>12</sup> F. de Siervo & F. de Leva, "Modern trends in selecting and designing Francis turbines", *Water Power & Dam Construction*, August 1976
- <sup>13</sup> F. de Siervo & F. de Leva, "Modern trends in selecting and designing Kaplan turbines", *Water Power & Dam Construction*, December 1977, January 1978
- <sup>14</sup> A. Lugaresi & A. Massa, "Designing Francis turbines: trends in the last decade", *Water Power & Dam Construction*, November 1987
- <sup>15</sup> A. Lugaresi & A. Massa, "Kaplan turbines: design trends in the last decade", *Water Power & Dam Construction*, May 1988
- <sup>16</sup> L. Austerre & J. de Verdehan, "Evolution du poids et du prix des turbines en fonction des progrès techniques", *Compte rendu des cinquièmes journées de l'hydraulique*, 1958, La Houille Blanche
- <sup>17</sup> H. Giraud & M. Beslin, "Optimisation d'avant-projet d'une usine de basse chute", *Symposium AIRH*. 1968, Lausanne
- <sup>18</sup> T. Belhaj, "Optimisation d'avant-projet d'une centrale hydroélectrique au fil de l'eau" *Symposium Maroc/CEE Marrakech* 1989
- <sup>19</sup> J.L. Gordon "A new approach to turbine speed", *Water Power & Dam Construction*, August 1990
- <sup>20</sup> J.L. Gordon "Powerhouse concrete quantity estimates", *Canadian Journal Of Civil Engineering*, June 1983
- <sup>21</sup> F. Schweiger & J. Gregori, "Developments in the design of Kaplan turbines", *Water Power & Dam Construction*, November 1987
- <sup>22</sup> F. Schweiger & J. Gregory, "Developments in the design of water turbines", *Water Power & Dam Construction*, May 1989
- <sup>23</sup> J. Fonkenell, "How to select your low head turbine", *Hydroenergia* 1991.

## CHAPTER 7: ENVIRONMENTAL IMPACT AND ITS MITIGATION

### CONTENTS

LIST OF TABLES.....	199
List of Photos.....	200
7 Environmental impact and its mitigation.....	201
7.1 Introduction.....	201
7.2 Burdens and impacts identification.....	202
7.3 Impacts in the construction phase.....	204
7.3.1 Reservoirs.....	204
7.3.2 Water intakes, open canals, penstocks, tailraces.....	205
7.4 Impacts arising from the operation of the scheme.....	205
7.4.1 Sonic impacts.....	205
7.4.2 Landscape impact.....	207
7.4.3 Biological impacts.....	215
7.5 Impacts from transmission lines.....	234
7.5.1 Visual impact.....	234
7.5.2 Health impact.....	235
7.6 Conclusion.....	235

### LIST OF FIGURES

Figure 7.1: Schematic of Candinanes scheme.....	209
Figure 7.2: Neckar scheme in cross-section.....	215
Figure 7.3: Example Flow Duration Curve.....	220
Table 7.3: Methods based on hydrologic or statistic values.....	221
Figure 7.4: Cross-section of a river bed.....	223
Figure 7.5: Relation between environmental flow and riverbed morphology.....	223
Figure 7.6: System of rectangular weirs.....	225
Figure 7.7: Fishpass baffles in section.....	226
Figure 7.8: Vertical slotted fish pass.....	227
Figure 7.9: Chutes and Vanes of Denil Fishpass.....	228
Figure 7.10: Section through Borland Lock.....	228
Figure 7.11: Water attraction facility.....	229
Figure 7.12 Coanda screen schematic.....	231
Figure 7.13: Bio-Acoustic Fish Fence.....	233

### LIST OF TABLES

Table 7.1: Impacts during Construction.....	203
Table 7.2: Impacts during Operation.....	204
Table 7.4: Methods based on physiographic principles.....	221
Table 7.5: Formulas based on velocity and depth of water.....	221
Table 7.6: Methods based on multi-objective planning taking into consideration ecological parameters.....	222

## **LIST OF PHOTOS**

Photo 7.1: Cordinanes.....	208
Photo7.2: Cordinanes Weir.....	209
Photo 7.3: Vilhelmina dam in Sweden .....	210
Photo 7.4: Intake.....	210
Photo 7.5: Construction phase – excavation.....	211
Photo 7.6:Construction phase – concrete canal .....	211
Photo 7.7: Construction phase – canal complete.....	212
Photo 7.8: Tunnel entrance during construction.....	213
Photo 7.9: Tunnel entrance covered .....	213
Photo 7. 10: Powerhouse .....	213
Photo 7.11: Substation located in Powerhouse.....	214
Photo 7. 12: Nekar power plant .....	214
Photo 7.13: Fishpass of rustic construction .....	225
Photo 7.14: Fishpass with vertical slots.....	226
Photo 7.15: A Denil Fishpass .....	227
Photo 7.16: Powerhouse and fishpass in the left .....	230
Photo 7.17: Coanda Screen in situation.....	232
Photo 7.18 Visual impact of outdoors substation.....	235



## **7 ENVIRONMENTAL IMPACT AND ITS MITIGATION<sup>1</sup>**

### **7.1 Introduction**

The “Third Conference of the Parties to the United Nations Framework Convention on Climate Change” was held in Kyoto in December 1997. This was the second initiative after the historic Rio Conference on Environment and Development in June 1992. Even earlier, the European Union had already recognised the urgent need to tackle the climate change issue. The “White Paper for a Community Strategy and Action Plan entitled: “Energy for the future: renewable sources of energy” was subsequently drafted providing a significant step forward.

Finally, the “Directive/77/EC of the European Parliament and of the council of 27 September 2001 on the promotion of electricity produced from renewable energy sources in the internal electricity market” set clear community targets. The global indicative target of 12% RE of gross domestic energy consumption by 2010 was stated. To achieve this ambitious goal all Member States have been required to set national indicative targets for the consumption of electricity produced from renewable sources.

A strategic study for the development of Small Hydro Power in the European Union: “Blue Age for a Green Europe” was completed in 2002 and gives a highly interesting survey of the potential of SHP by different approaches. EU countries estimate, under economic and environmental constraints, an increase in capacity of 1111 MW by upgrading existing plants (annual production of 4518 GWh) and an increase in capacity of 4828 MW by the realisation of new small hydroelectric plants (annual production of 19645 GWh).

The technical potential with only technical constraints would represent a doubling of above mentioned figures: 2080 MW (8100 GWh/year) by upgrading existing plants and 9615 (38058 GWh/y) by new plants could be achieved theoretically. The achievement of the “theoretical” objective (46158 GWh/y) will imply an annual reduction of 20 million tonnes of CO<sub>2</sub> emissions based on a prudential value (gas fired plants) of 0.43 kg<sub>CO2</sub>/kWh.

However, under present trends the above objective will not be attained so long as the administrative procedures to authorise the use of water are not accelerated. Hundreds, if not thousands, of authorisation requests are pending approval, the delay being caused mainly by perceived conflict with the environment. Some environmental agencies seem to justify or at least excuse - this blockade on the grounds of the low capacity of the small plants. It seems to be forgotten that by definition, renewable energies are decentralised and that currently only small hydro power plants and the wind turbines can significantly contribute to renewable electricity production.

At the same time whilst it should be accepted that electricity production in small hydro plants does not produce carbon dioxide or liquid pollutants, the fact is that due to their location in sensitive areas local impacts are not always negligible. The significant global advantages of small hydropower must not prevent the identification of burdens and impacts at local level and the taking of necessary mitigation actions. Large thermal plants, because of their economic relevance and scale, are authorised at very high administrative levels and in some cases, their impacts cannot be mitigated at present. A small hydropower scheme producing impacts that usually can be mitigated is considered at lower administrative levels, where the influence of pressure groups - angling associations, ecologists, etc.- is greater.

It is not difficult to identify the impacts, but to decide which mitigation measures should be undertaken it is not simple, because these are usually dictated by subjective arguments. It is therefore strongly recommended to establish a permanent dialogue with the environmental

authorities as a very first step in the design phase. Even if this negotiation must be considered on a project-by-project basis it would be convenient to provide a few guidelines that will help the designer to propose mitigating measures that can easily be agreed with the licensing authorities.

Recently, the implementation of the Water Framework Directive will introduce severe additional demands in ecological terms. There is little doubt, that the fulfilling of ecological aims such as the construction of fish bypass systems or the reduction of water through increased reserved flow has significant cost implications and reduces the viability of SHP. The achievement of environmental goals is not dependent on the ideological resistance of the developer of the site but on his economical restrictions. In reality, the “environmental problem” has economical parents.

## **7.2 Burdens and impacts identification**

Impacts of hydropower schemes are highly location and technology specific. A high mountain diversion scheme situated in a highly sensitive area is more likely to generate an impact than an integral low-head scheme in a valley. The upgrading and extension of existing facilities, which will be given priority in Europe, generates impacts that are quite different from an entirely new scheme. For example, in mountain diversion projects that use the large change in elevation of a river, the water is diverted from the main river and re-enters again at the tailwater below the power plant. In this case, entire areas of the main river may be bypassed by a large volume of water, when the plant is in operation.

Given in Table 7.1 and 7.2 below is an exhaustive description of possible impacts, based on European studies<sup>2</sup> dealing with externalities, and made by groups of experts that perform Environmental Impact Assessments. However is not certain that all or most of this list of descriptions will be applicable to a specific project. In the list are identified the event, persons or things affected, impact and priority at local and national levels.

**Table 7.1: Impacts during Construction**

<b>Events during construction</b>	<b>Persons or things affected</b>	<b>Impact</b>	<b>Priority</b>
Geological Surveys	Wildlife	Noise	Low
Existing Vegetation Cutting	Forestry	Alteration of habitat	Medium
Enlargement of Existing Roads	General public	Creation of opportunities, alteration of habitat	Medium
Earth Moving	Site geology	Slope stability	Low
Tunnels Excavation	Site hydro-geology	Alteration of groundwater circulation	Low
Permanent Filling Material on Slopes	Site geology	Slope stability	Low
Embankment Realisation	Aquatic life, site hydro-morphology	Alteration of river hydraulic	Medium
Creation of Temporary Earth Accumulations	Site geology	Slope stability	Low
Temporary Displacement of Persons, Roads, Electric Lines	General public		Negligible
Realisation of Roads and Sheds for the Yard	Wildlife, general public	Visual intrusion, wildlife disturbance	Low
Water Courses Dredging	Aquatic ecosystem	Alteration of habitat	Medium
Temporary Diversion of Rivers	Aquatic ecosystem	Alteration of habitat	High
Use of Excavators, Trucks, Helicopters, Cars for the Personnel, Blondins	Wildlife, general public	Noise	High
Human Presence During the Works on Site	Wildlife, general public	Noise	Low

**Table 7.2: Impacts during Operation**

Events during operation	Persons or things affected	Impact	Priority
Renewable Energy Production	General public	Reduction of Pollutants	High
Watercourses Damming	Aquatic ecosystem	Modification of habitat	High
Permanent Works in the Riverbed	Aquatic ecosystem	Modification of habitat	High
Diversion of Watercourses	Aquatic ecosystem	Modification of habitat	High
Penstocks	Wildlife	Visual intrusion	Medium
New Electric Lines	General public, wildlife	Visual intrusion	Low
Riprap	Aquatic ecosystem, general public	Modification of habitat, visual intrusion	Low
Levees	Aquatic ecosystem, general public	Modification of habitat, visual intrusion	Low
Flow Rate modification	Fish	Modification of habitat	High
	Plants	Modification of habitat	Medium
	General public	Modification of recreational activities	
Noise from electromechanical equipment	General public	Alteration of life quality	Low
Removal of material from streambed	Aquatic life, General public	Improvement of water quality	high

### 7.3 Impacts in the construction phase

Schemes of the diversion type, multipurpose reservoir, inserted on an irrigation canal or built into a water supply system produce very different impacts from one another, from both a quantitative and qualitative viewpoint. A scheme making use of a multipurpose dam has practically no unfavourable impacts, since it is understood that when the dam was built the necessary mitigating measures were already incorporated. Even the location of the powerhouse will be at the base and shall not alter the ecological system.

Schemes integrated in an irrigation canal or in a water supply pipe system will not introduce new impacts over those generated when the canal and the pipe system were developed. On the other hand, diversion schemes present very particular aspects that need to be analysed.

#### 7.3.1 Reservoirs

The impacts generated by the construction of a dam and the creation of the adjoining reservoir include, in addition to the loss of ground, the construction and opening of construction roads, working platforms, excavation works, blasting and even -depending of the dam size- concrete manufacturing plants. Other non-negligible impacts are the barrier effect and the alteration of flow consequent to a river regulation that did not exist before. It has to be underlined that reservoirs are in fact not typical for small hydropower plants. The majority of SHP belongs to the run-off type without any big, dam-like construction works.

However, the impacts generated by the construction of a dam do not differ from those induced by any large-scale infrastructure development, whose effects and mitigating measures are well known.

### 7.3.2 Water intakes, open canals, penstocks, tailraces

The impacts generated by the construction of these structures are well known and have been described in Table 1, e.g. noise affecting the life of animals, danger of erosion due to the loss of vegetation through excavation work, turbidity of the water and downstream sediment deposition, etc. To mitigate such impacts it is strongly recommended that the excavation work should be undertaken in the low water season and the disturbed ground restored as soon as possible. In any case these impacts are always transitory and do not constitute a serious obstacle to the administrative authorisation procedure.

In view of its protective role against riverine erosion it is wise to restore and reinforce the riverbank vegetation that may have been damaged during construction of the hydraulic structures. It should be noted that the ground should be repopulated with indigenous species, best adapted to the local conditions.

The impact assessment study should take account of the effects of dispersing excavated material in the stream and the unfavourable consequences of construction workers living in a usually uninhabited area during the construction period. This impact, which may be negative if the scheme is located in a natural park, would be positive in a non-sensitive area by increasing the level of its activity. Vehicle emissions, excavation dust, the high noise level and other minor burdens contribute to damaging the environment when the scheme is located in sensitive areas. To mitigate the above impacts the traffic operation must be carefully planned to eliminate unnecessary movements and to keep all traffic to a minimum.

On the positive side, it should be noted that the increase in the level of activity in an area, by using local manpower and small local subcontractors during the construction phase is to be welcomed.

## **7.4 Impacts arising from the operation of the scheme**

### 7.4.1 Sonic impacts

The allowable level of noise depends on the local population or isolated houses near to the powerhouse. The noise comes mainly from the turbines and, when used, from the speed increasers. Nowadays noise inside the powerhouse can be reduced, if necessary, to levels in the order of 70 dBA, almost imperceptible when outside.

Concerning sonic impact, the Fiskeby<sup>3</sup> power plant in Norrköping, Sweden is an example to be followed. The scheme owner wanted a maximum internal sound level of 80 dBA inside the powerhouse at full operation. The maximum allowed external sound level, at night, was set at 40 dBA in the surroundings of some houses located about 100 metres away.

To reach these levels of noise it was decided that all the components - turbines, speed increasers, and asynchronous generators - were bought in one package from one well-known supplier. The purchase contract specified the level of noise to be attained in full operation leaving the necessary measures to fulfil the demands to the manufacturer. The supplier adopted the following measures: very small tolerances in the gear manufacturing; sound insulating blankets over the turbine casing; water cooling instead of air cooling of the generator and a careful design of ancillary components. As well as the usual thermal insulation, the building was provided with acoustic insulation. Consequently, the attained level of noise varied between 66 dBA and 74 dBA, some 20 dBA lower than the average Swedish powerhouses. Having a single supplier, the issue of responsibility was eliminated.

The external noise level reduction was obtained by using vibration insulation of the powerhouse walls and roof. The principle for the vibration reduction system was to let the base slab, concrete waterways and pillars for the overhead crane be excited by vibration from the turbine units. The other parts of the building such as supporting concrete roof beams and pre-cast concrete elements in the walls were supported by special rubber elements designed with spring constants giving maximum noise reduction. For the roof beams, special composite spring-rubber supporting bearings (Trelleborg Novimbra SA W300) were chosen. A similar solution was chosen for the pre-cast wall components. Once built, the sound emission from the powerhouse could not be detected from the other noise sources as traffic, sound from the water in the stream, etc. at the closest domestic building.

The underground powerhouse of Cavaticcio<sup>4</sup>, located about 200 m from the Piazza Maggiore, the historical heart of Bologna, has also merits in this respect. An acoustic impact study undertaken on Italian schemes showed an average internal level of about 85 dBA. The level of noise near the houses close to the proposed powerhouse was 69 dBA by day and 50 dBA by night. The regulations in force required that these values could not increase by more than 5 dBA during the day and 3 dBA during the night. The measures carried out to fulfil the requirements were similar to those undertaken in Fiskeby:

- Insulation of the machine hall, the most noisy room, from the adjacent rooms by means of double walls with different mass, with a layer of glass wool in between.
- Soundproofing doors.
- Floors floating on 15 mm thick glass wool carpets.
- False ceiling with noise deadening characteristics.
- Heavy trapdoors to the ground floor, fitted with soundproof counter trapdoors and neoprene sealing gaskets.
- Vibration damping joints between fans and ventilation ducts.
- Low air velocity (4 m/sec) ducts.
- Two silencers at the top and rear of the ventilation plant.
- Inlet and outlet stacks equipped with noise traps.
- Air ducts built with a material in sandwich (concrete, glass wool, perforated bricks and plaster).
- Turbine rotating components dynamic balanced.
- Water-cooled brushless synchronous generator.
- Precision manufactured gears in the speed increaser.
- Turbine casings and speed increaser casings strongly stiffened to avoid resonance and vibrations.

- Anchoring of the turbine by special anti-shrinking concrete to ensure the monolithic condition between hydro unit and foundation block.
- Turbine ballasting with large masses of concrete to reduce to a minimum the vibration's amplitude.

The underground ventilation has three main purposes: dehumidification of the rooms to ensure a correct operation and maintenance of the equipment, fresh air supply for the workers and removal of the heat generated by the various plant components. Even with the maximum volume of air circulation estimated at 7000 m<sup>3</sup>/hour the air velocity in the air ducts never exceeds 4 m/sec.

It is true that the two above examples are very particular ones but they are included here to show that everything is possible if it is considered necessary although the project may require a significant increase in the investment. It is also true that both examples concern low head schemes implying the use of speed increasers; a high mountain diversion scheme would permit the direct coupling of turbine and generator, so eliminating the component responsible for most of the vibrations.

#### 7.4.2 Landscape impact

The quality of visual aspects is important to the public, who is increasingly reluctant to accept changes taking place in their visual environment. For example, a new condominium in our neighbourhood with an artificial beach built with sand coming from a submarine bed was rejected by a part of the population, even though, in many ways it would improve the environment including landscaping. The problem is particularly acute in the high mountain hydropower schemes or in schemes located in an urban area. This concern is frequently manifested in the form of public comments and even of legal challenges to those developers seeking to change a well-loved landscape by developing a hydropower facility.

Each of the components that comprise a hydro scheme - powerhouse, weir, spillway, penstock, intake, tailrace, substation and transmission lines - has potential to create a change in the visual impact of the site by introducing contrasting forms, lines, colour or textures. The design, location, and appearance of any one feature may well determine the level of public acceptance for the entire scheme.

Most of these components, even the largest, may be screened from view using landscaping and vegetation. Painted in non-contrasting colours and textures to obtain non-reflecting surfaces a component will blend with or complement the characteristic landscape. Creative effort, usually with small effect on the total budget, can often result in a project acceptable to all parties concerned: local communities, national and regional agencies, ecologists etc.

The penstock is usually the main cause of "nuisance". Its layout must be carefully studied using every natural feature - rocks, ground, vegetation - to shroud it and if there is no other solution, painting it so as to minimise contrast with the background. If the penstock can be interred, this is usually the best solution, although the operator has to meet some disadvantages in terms of maintenance and control. Expansion joints and concrete anchor blocks can then be reduced or eliminated; the ground is returned to its original state and the pipe does not form a barrier to the passage of wild life.

The powerhouse, with the intake, the penstock tailrace and transmission lines must be skilfully inserted into the landscape. Any mitigation strategies should be incorporated in the project, usually without too much extra cost to facilitate permit approval.

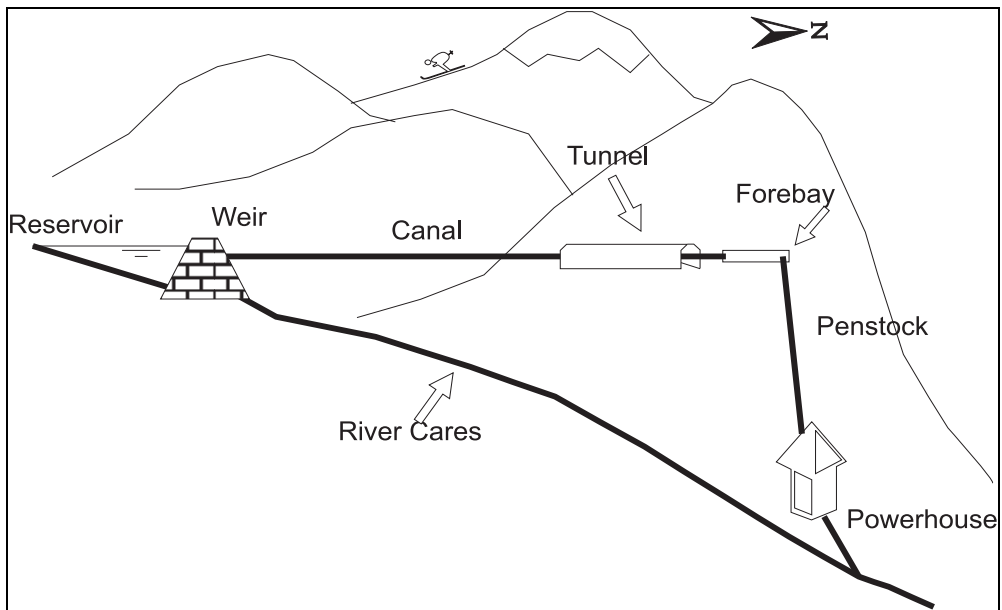
The examination of two schemes carefully designed to shroud their components will convey to potential designers a handful of ideas that should help to convince the environmental authorities that there is no place so environmentally sensitive as to prevent the development of a energy conversion process, so harmless and acceptable. The Cordinanes scheme in Picos de Europa (Spain) and the scheme on the river Neckar, located in the historical centre of Heidelberg (Germany) are considered below.

A small reservoir such as the one existing in Cordinanes (Photo 1) has some positive aspects. The existence of an almost stable level of water, and the tourist attractions (swimming, fishing, canoeing, etc.) that it provides counter balance its negative effects. Figure 1 shows a schematic view of the Cordinanes scheme.



**Photo 7.1: Cordinanes**





**Figure 7.1: Schematic of Cordinanes scheme**

The weir is a relatively airy concrete structure, but being 14 m high it is the most obtrusive component in the scheme (Photo 2). It needs to be so high because the water must reach the level of an old tunnel that, once rebuilt, will make part of the diversion canal. That is precisely the reason why the water level in the reservoir cannot vary by more than two metres and confers to the pond the character of a picturesque lake.



**Photo7.2: Cordinanes Weir**

And while referring to dams the Vilhelmina dam in Sweden, constructed of soil materials with an impervious core, should be mentioned (Photo3). The surface of the crest and the downstream slope

are protected against erosion by layers of large stones and boulders, which are embedded in reinforced concrete up to half their height. The downstream slope has a normal inclination of 1:3 except for a part, 40 m wide, where the inclination is 1:10. This design makes it possible for fish to pass up the dam enroute upstream. This dam has another environmental advantage since even with a small discharge it has the appearance of a natural rapid.



**Photo 7.3: Vilhelmina dam in Sweden**

An open canal built in reinforced concrete leaves, from the intake (Photo 4), with a section of 2 x 2.5 m and a length of 1335 m, entirely buried and covered by a layer of soil and vegetation.



**Photo 7.4: Intake**

Photo 5, Photo 6 and Photo 7 show a stretch of the canal in its three construction phases: land excavation reinforced concrete canal and finished canal with the recovered vegetal layer. The presence in the photographs of an electrical pylon - the transmission line between the villages of Posada de Valdeon and Cordinanes - confirms that it is the same site, because otherwise it would be impossible to identify the buried canal.



**Photo 7.5: Construction phase – excavation**



**Photo 7.6: Construction phase – concrete canal**



**Photo 7.7: Construction phase – canal complete**

Photo 8 and Photo 9 show how the entrance to the tunnel has been shrouded. In the first one the tunnel being rebuilt can be seen; in the second the canal connecting with the tunnel has been covered, as has the rest of the canal including the entrance to the tunnel. It is possible to enter the tunnel through the canal for inspection, after it is de-watered. In fact the tunnel already existed but was unfinished due to the lack of means to cross the colluvium terrain. It has now been rebuilt with a wet section of 2 x 1.80 m and with a 1:1000 slope, which conducts the water down to forebay, which is a perfect match with the surrounding rocks and has a semicircular spillway. From the forebay a steel penstock, 1.40 m diameter and 650 m long, brings the water to the turbines. In its first 110 m, the pipe has a slope close to 60°, in a 2.5 x 2 m trench excavated in the rock. The trench was filled with coloured concrete to match the surrounding rocks. A further trench was excavated in the soil and conceals the other 540 m, which as then covered by vegetation later on.



**Photo 7.8: Tunnel entrance during construction**



**Photo 7.9: Tunnel entrance covered**

Few metres before arriving at the powerhouse the pipe bifurcates into two smaller pipes that feed two Francis turbines of 5000 kW installed power each. The powerhouse (Photo10) is similar to the houses dotting the mountain. Its limestone walls, old roof tiles and heavy wood windows don't show its industrial purpose. In addition the powerhouse is buried for two thirds of its height also improving its appearance. To conceal the stone work of the tailrace a waterfall has been installed.



**Photo 7. 10: Powerhouse**

The substation is located in the powerhouse (Photo 11), in contrast with the usual outer substation (see photo 17), and the power cables leave the powerhouse over the penstock, under the tunnel and over the open canal. Close to the village where there are several transmission lines the power cables

come to the surface, to be buried again when the line transverses the north slope, a habitat of a very rare bird species - the "Urogayo".



**Photo 7.11: Substation located in Powerhouse**

The Neckar power plant (Photo 12) is located in the historical centre of Heidelberg<sup>5</sup> and was authorised under the condition that it would not interfere with the view of the dam built in the past to make the river navigable. The powerhouse, built upstream of the dam, is entirely buried and cannot be seen from the riverbank. Figure 2 shows better than a thousand words the conceptual design, where stand two Kaplan pit turbines, and each one with a capacity of 1535 kW. The investment cost was of course very high - about 3760 ECU/installed kW.



**Photo 7. 12: Nekar power plant**

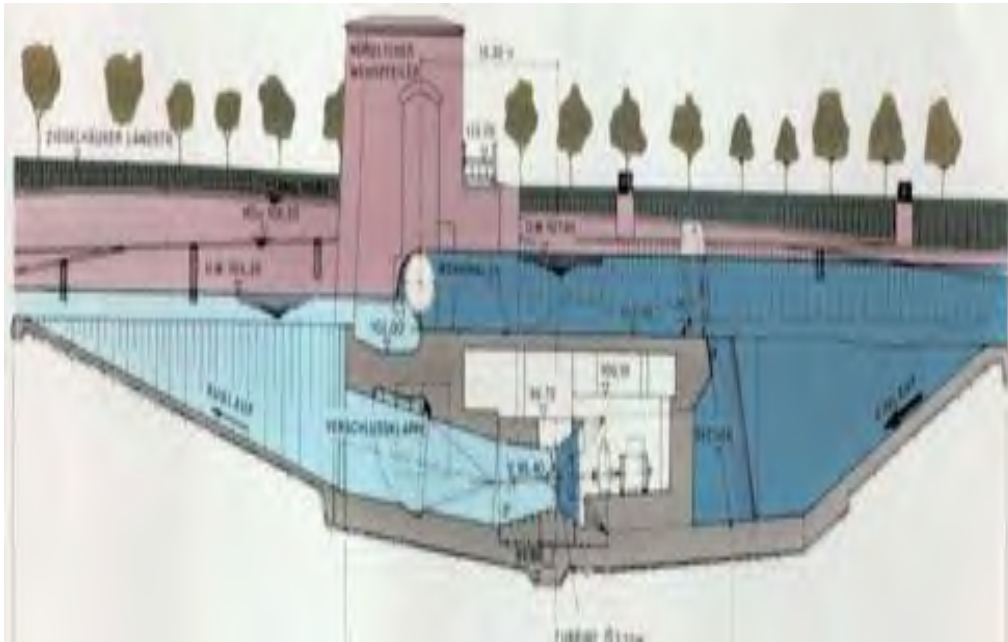


Figure 7.2: Neckar scheme in cross-section

### 7.4.3 Biological impacts

#### 7.4.3.1 In the reservoir

Reservoir projects are very unusual in small hydropower although there are some schemes that store enough water to operate the turbine only during the periods of maximum electrical demand. Such operation is referred to as "peaking" or "peak-opping". In integral low head schemes, peaking can result in unsatisfactory conditions for fish downstream because the flow decreases when the generation is reduced. The lower flow can result in stranding newly deposited fish eggs in spawning areas. The eggs<sup>6</sup> apparently can survive periods of de-watering greater than those occurring in normal peaking operation but small fish can be stranded particularly if the level fall is rapid.

#### 7.4.3.2 In the streambed

A substantial proportion of small hydro plants are of the diversion type, where water is diverted from a stream or a lake into a hydroelectric plant perhaps kilometres from the diversion point to take advantage of the gain in head. The reduction in flow in the streambed between the point of diversion and the tailrace downstream of the powerhouse may affect spawning, incubation, rearing, and the passage of fish and of living space for adult fish.

Concerning peak operation – not typical for SHP – significant and frequent changes of discharge can ruin aquatic life because certain reaches of the riverbed are “flooded” and then dry up again periodically.

There is here a clear conflict of interest. The developer will maintain that the generation of electricity with renewable resources is a very valuable contribution to mankind, by replacing other conversion processes emitting greenhouse gases. The environmentalists will say, on the contrary, that the water diversion in the stream represents a violation of the public domain.

#### 7.4.3.2.1 Reserved Flow

The formulas for calculation of reserved are many and their numbers tend to increase day by day. This demonstrates that no one has a good universally valid solution for reserved flow determination. In the following pages, some of the formulas subdivided by principle of calculation are provided. Each formula can only supply a value to be used as a reference for regulatory purposes.

A more complete survey on methods for calculating reserved flow can be found in the document prepared by ESHA within the Thematic Network on Small Hydroelectric Plants and available at the web address [www.esha.be](http://www.esha.be).

#### 7.4.3.2.2 Methods based on hydrologic or statistic values

One method group refers to the average flow rate (MQ) of the river at a given cross section. The resulting reserved flow varies from 2,5 % of MQ for the Cemagref method applied in France to 60% for Montana (USA) method applied in the case where fisheries have a high economic importance. Typically, a figure of 10 % of the average flow is used for reserved flow.

A second method group refers to the minimum mean flow (MNQ) in the river. The reserved flow calculated when applying these methods varies from 20% (Rheinland-Pfalz, Hessen [D]) to 100% (Steinbach [A]) of MNQ.

A third method group refers to the prefixed values on the Flow Duration Curve (FDC). In this group a large variety of values are chosen as reference:

Q<sub>300</sub> (Swiss Alarm limit value method, Matthey and linearised Matthey),

Q<sub>347</sub> (German Büttinger method),

NMQ<sub>7</sub> (the lowest mean value of flow rate in the seven months with the higher natural discharges),

NMQ<sub>Aug</sub> (the minimum mean flow in August), Q<sub>84%</sub>, Q<sub>361</sub>, Q<sub>355</sub> and so on.

#### 7.4.3.2.3 Methods based on physiographic principles

These methods usually refer to a constant specific reserved flow (l/s/km<sup>2</sup> of catchment area). In addition, in this case the values of reserved flow suggested are highly variable. For example, a figure of 9.1 l/s/km<sup>2</sup> is required in the USA where rivers have an excellent abundance of fish down to 2 l/s/km<sup>2</sup> of the crystalline catchments in the Alps.

#### Advantages of these methods

- Easily applicable under the presupposition of good basic data,
- Natural fluctuation could be eventually taken into account,
- Supply of a rough evaluation of the economic energy production,
- Methods based on MNQ or NNQ should be preferred,
- No recognisable ecological background.



### Disadvantages

- Academic formulas which supply rigid values,
- NNQ could be easily underestimated,
- No consideration for hydraulic parameters of flow,
- Effect of tributaries or abstractions in the diversion section and the diversion length no taken into account,
- Economic operation of small hydroelectric plants could be hardly affected,
- Methods not suitable for many typologies of rivers and doubtful transferability from river to river.

#### 7.4.3.2.4 Formulas based on velocity and depth of water

In this group of methods, we also have a great variation of values suggested for the typical parameters. Water velocity can range from 0,3 m/s (Steiermark method) to 1,2-2,4 m/s (Oregon method) and water depth must be higher than 10 cm (Steiermark method) to 12-24 cm (Oregon method).

Other formulas falling into this group suggest a reserved flow referred to river width (30-40 l/s per meter of width) or to the wetted perimeter (in case of reserved flow the wetted perimeter must be at least 75% of the undisturbed flow).

### Advantages of this method

- Main flow characteristics are maintained,
- The shape of profile can be included in the calculation,
- Individual river approach,
- No hydrological data needed,
- Only indirect and general relations with ecological parameters,
- Suitable to evaluate the consequences on energy production economics.

### Disadvantages

- Slope and natural water pattern don't enter in the calculation,
- Diversion length and effect of tributaries or abstractions stay unconsidered,
- Without river re-structuring measures, in wide rivers these methods give very high values of reserved flow,
- Reasonable use only for particular kind of depleted reach,

- In mountain torrents give unrealistic values of threshold water depth,
- Suitable only for particular typologies of rivers, transferability doubtful.

#### 7.4.3.2.5 Methods based on multi-objective planning taking into consideration ecological parameters

Due to the high specificity of these methods, which is hard to condense into a word, a short description is given.

#### ***MODM [Multi Objective Decision Making]***

The determination of reserved flow results from a model, which considers both ecological and economic objectives. The solution to be chosen must have the best compromise value of both kinds of parameters. The following measured variables are used as parameters:

- Opportunity for regular work (economy)
- Smallest maximum depth (diversity of species and individual size)
- Highest water temperature (change of thermal conditions)
- Smallest oxygen contents (water quality)

#### ***Dilution ratio***

The necessary discharge must be at least 10 times of the introduced, biologically cleaned discharge. The velocity can't fall below 0,5 m/s.

#### ***Flow parameters***

The effects of reserved flow are measured with the help of a model. From this necessary corrections and/or construction measures in the diversion area can be derived.

#### ***PHABSIM***

This method is based upon the knowledge of the combination of the parameters - water depth, flow velocity, temperature and sediment preferred by the majority of fish species. Under these presuppositions have been defined, both technically and with respect to the desired spectrum of fish species, the reserved flow necessary can be calculated.

#### ***Habitat Prognoses Model***

In order to limit the expenditure-intensive investigations for the determination of the reserved flow conditions in difficult cases, this model was developed. The model operates based on fewer aggregated-morphologic parameters, the reserved discharge conditions relevant for the biogenesis can be prognosticated computationally. A "minimum ecological discharge" and an "economic energy" threshold value are determined. The final residual flow suggested would be a function of both these values, whereby the following facts are considered. It applies a degradation prohibition with respect to the current conditions. The residual flow suggestion may not exceed the minimum ecological discharge.

Reserved flow is the economic energy threshold value or 4% of the small hydroelectric plant flow rate. Reserved flow must be 5/12 of MNQ as a maximum.

### ***Habitat Quality Index (USA)***

This model is based on multiple regression. It links the so-called bearing capacity for Salmonids in a stretch of river with a set of ecological parameters. It requires the collection of a great number of different environmental data necessary to calculate the biomass of Salmonids, which can live in the identified stretch of river.

### ***Pool Quality Index***

This model is derived from the HQI method, it's based on the maximisation of the hydraulic diversity i.e. the higher the number of pools in a torrent, and the lower the reserved flow is. Depending on the percentage of pools the method supplies the following values for reserved flow to be compared with values obtained by methods described in 7.4.3.2.2, 7.4.3.2.3 and 7.4.3.2.4:

- 7 – 9 % of MQ
- 50 – 70 % of  $Q_{355}$
- 3.6-4,3 l/s/km<sup>2</sup>

### ***Definition of the dotation water delivery through dotation attempts***

The concept of “dotation” corresponds to the artificially regulated flow rate at a certain time and in a certain cross section to guarantee a required amount of water in a different cross section of the same river.

This method is based on the determination of the reserved flow conditions in combination with the simulation of potential future conditions in the diverted section of the river.

The method represents the connection with ecologically relevant parameters with available realisations concerning preference ranges and/or preference curves. It is described as rather simple and economical method. It presupposes however the possibility of measuring small discharges in the future diversion section of the river. With existing plants, this is simple - in all other cases low-water periods must be used for these measurements and will almost certainly require extrapolation.

### **Advantages of this method**

- Site specific flow observations
- Taking into account of hydrological, hydraulic, ecological, and meteorological quantities
- Consideration of both ecological and economical parameters

### **Disadvantages**

- Methods expensive in data collecting and mathematical computing
- Suitable only for particular typologies of rivers, transferability doubtful.

Example of application of different methods using the following criteria

A =	120 km <sup>2</sup>	Q <sub>300</sub> =	1.90 m <sup>3</sup> /s
Average river width:	20 m, approx. rectangular	Q <sub>347</sub> =	1.60 m <sup>3</sup> /s
Average river slope:	2.3%	Q <sub>355</sub> =	1.38 m <sup>3</sup> /s
MQ =	2.33 m <sup>3</sup> /s	Q <sub>361</sub> =	0.37 m <sup>3</sup> /s
		NMQ =	0.15 m <sup>3</sup> /s

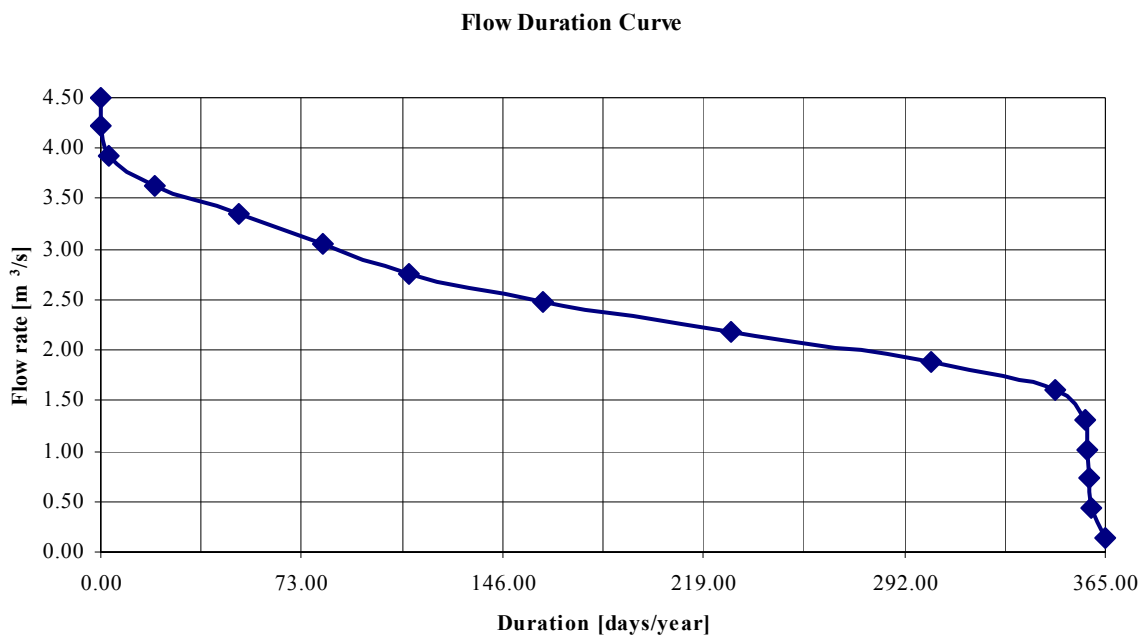


Figure 7.3: Example Flow Duration Curve

**Table 7.3: Methods based on hydrologic or statistic values**

METHOD	DESCRIPTION	RESERVED FLOW (L/S)	METHOD	DESCRIPTION	RESERVED FLOW (L/S)
10% MQ		233	Rheinland-Pfalz	$0,2 - 0,5 \cdot Q_{365}$	30-75
Lanser	5-10% MQ	116-233	Hessen	$0,2 - 0,9 \cdot Q_{365}$	30-135
Cemagref	2,5-10% MQ	58-233	Q <sub>361</sub>		370
Steinbach	Q <sub>365</sub>	150	Alarm limit	0,2 Q <sub>300</sub>	380
Baden-Württemberg	$1/3 \cdot Q_{365}$	50	Büttinger	Q <sub>347</sub>	1.600

**Table 7.4: Methods based on physiographic principles**

METHOD	DESCRIPTION	RESERVED FLOW (L/S)	METHOD	DESCRIPTION	RESERVED FLOW (L/S)
USA	2,6-9,1 l/s/km <sup>2</sup>	312-1.092	Tirol	2-3 l/s/km <sup>2</sup>	240-360
Lombardy	2,88 l/s/km <sup>2</sup>	346			

**Table 7.5: Formulas based on velocity and depth of water**

METHOD	DESCRIPTION	RESERVED FLOW (L/S)	METHOD	DESCRIPTION	RESERVED FLOW (L/S)
Steiermark	0,3-0,5 m/s	80-290	Oregon	1,2-2,4 m/s	2600-15000
Oberösterreich	hw ≥ 20 cm	7150	Steiermark	hw ≥ 10 cm	2290
Miksch	30-40 l/s/m <sub>width</sub>	600-800	Tirol	hw ≥ 15-20 cm	4450-7150

**Table 7.6: Methods based on multi-objective planning taking into consideration ecological parameters**

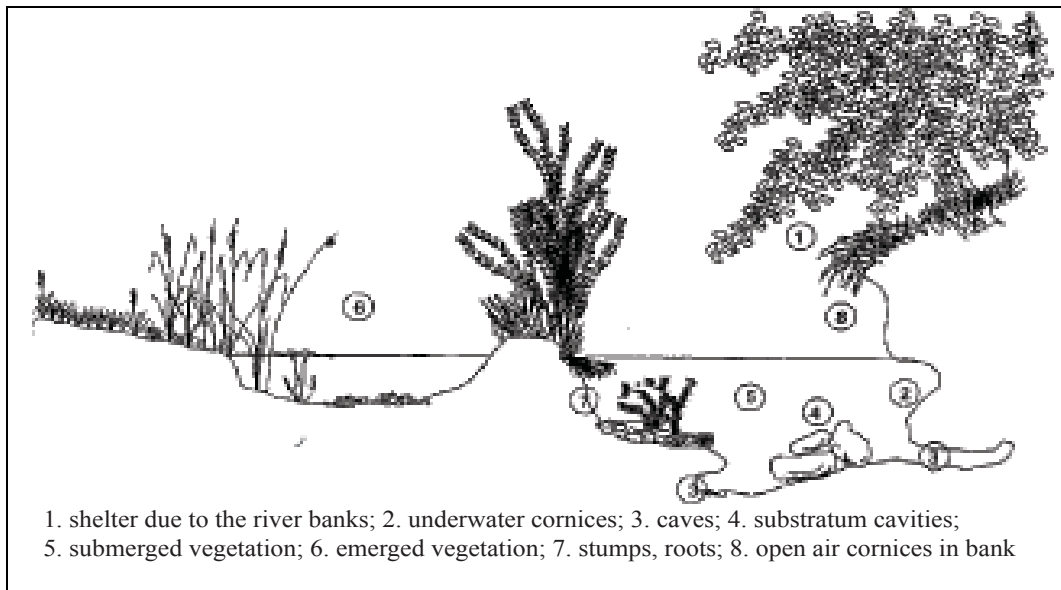
METHOD	DESCRIPTION	RESERVED FLOW (L/S)	METHOD	DESCRIPTION	RESERVED FLOW (L/S)
PQI	7 – 9 % MQ	163-210	PQI	50–70% Q <sub>355</sub>	690-966
Oberösterreich	3,6-4,3 l/s/km <sup>2</sup>	432-516	Steiermark	hw≥10 cm	2290

The tabled examples show a large variation and underline how difficult the applying of these methods can be is when calculating the reserved flow to be released downstream of a water diversion work. In particular the application of the formulas based on velocity and depth of water leads to unreasonable values.

In this context, it makes sense to think about river restructuring methods to reduce the amount of reserved flow. This approach allows the double opportunity of achieving a better environmental efficiency of the water released (water depths and velocities suited to the ecosystem requirements) and the increase in energy production from a renewable source.

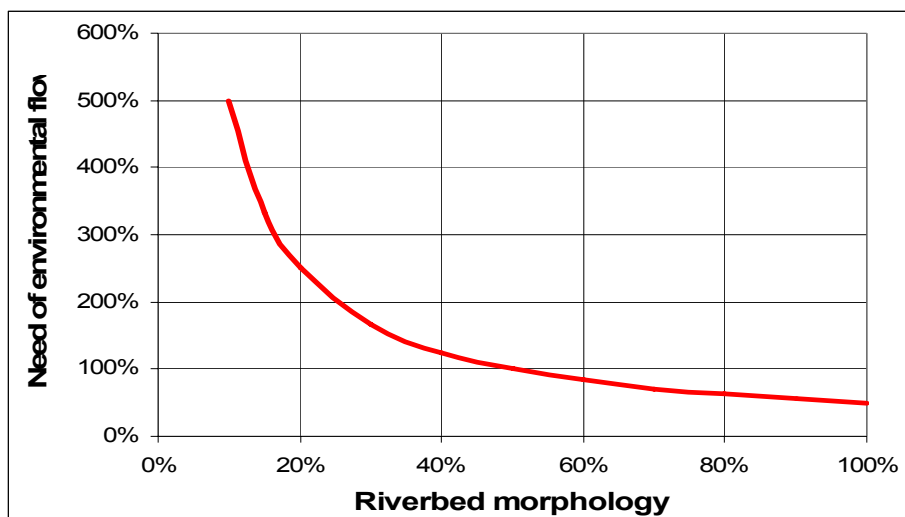
It must be underlined that if any of the biological methods (for defining the reserved flow value) are implemented, then there is a possibility for the developer to decrease the level of the required reserved flow through modifying the physical structure of the streambed. Well-known measures of river rehabilitation and river restructuring perform perfectly within these efforts. Measures such as growing trees on the riverbanks to provide shadowed areas, gravel deposits in the streambed to improve the substratum, reinforcement of the riverside through shrubs to fight erosion, etc can all assist. The investment necessary for these measures is most likely compensated very quickly by a significant decrease of reserved flow.

Figure 4 (reproduced from a paper by Dr. Martin Mayo) illustrates the kind of coverage and refuge against the flow, sunshine and danger that can be given to vertebrates and invertebrates by both natural and artificial elements. The existence of caves and submerged cornices provides a safe refuge against the attacks of a predator. In addition, the riverine vegetation close to the water provides shade used by fish to prevent overheating and provides concealment in face of terrestrial predators. (It must be said that the most dangerous terrestrial predator is the freshwater fisherman). All these elements contribute to the concept that in the WUW (Weighted Useful Width) APU method is known as refuge coefficient. By increasing its importance, the required value of the reserved flow may be diminished. In that way, a better protection of the aquatic fauna can be combined with a higher energy production.



**Figure 7.4: Cross-section of a river bed**

Just for demonstration purposes – the relation between environmental flow and riverbed morphology looks like the following graph:



**Figure 7.5: Relation between environmental flow and riverbed morphology**

Out of the many possible types of works it's worth mentioning the creation of pools for fish breeding, meandering low water riverbeds to increase velocities and depths in the case of low flow, modification of the slope to increase the water depths concentrating in small waterfalls or ramps (30-40 cm) the consequent sudden slope changes.

The difficulty with these types of works is in making the modification permanent, i.e. resistant to floods and natural riverbed dynamics that should not be underestimated.

A more complete survey on the effects of additional parameters on reserved flow (slope, tributaries, river structure and so on) can be found in the document prepared by ESHA within the Thematic Network on Small Hydroelectric Plants and available at the web address [www.esha.be](http://www.esha.be).

#### 7.4.3.2.6 Fish passes (upstream fish)

Anadromous fish are those, which spawn in fresh water but spend most of their lives in the ocean. Catadromous fish are those that spawn in the ocean, reach adulthood in fresh water and require passages at dams and weirs. A great variety of fish pass designs are available, depending on the species of fish involved. Otherwise, freshwater fish seem to have restricted movements.

Upstream passage technologies are considered well developed and understood for certain anadromous species including salmon. According to OTA 1995 (Office of Technology Assessment in the U.S.A.) there is no single solution for designing upstream fish passageways. Effective fish passage design for a specific site requires good communication between engineers and biologists, and thorough understanding of site characteristics. Upstream passage failure tends to result from a lack of adequate attention to operation and maintenance of facilities.

The upstream passage can be provided for through several means: fish ladders, lifts (elevators or locks), pumps and transportation operations. Pumps are a very controversial method. Transportation is used together with high dams. These highly technical approaches are rather unusual in small hydropower schemes. A great variety of constructions and design of fish bypass systems is the main approach in SHP. Site and species-specific criteria and economics would determine which solution is most appropriate.

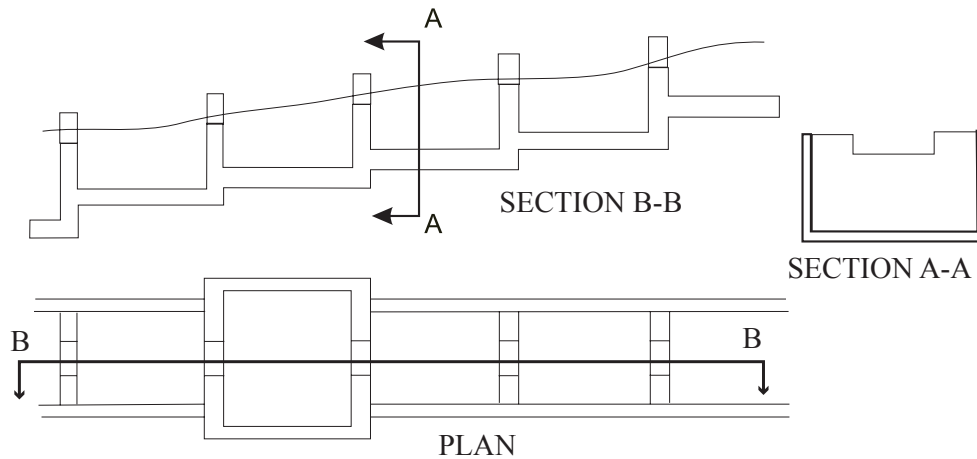
Fish bypass systems (natural-like creek without steps, pool and weir, Denil-passes, vertical slots, hybrid etc.) can be designed to accommodate fish that are bottom swimmers, surface swimmers or orifice swimmers. However, not all kinds of fish will use ladders. Fish elevators and locks are favoured for fish that does not use ladders

The most common fish pass is the weir and pool fish pass, a series of pools with water flowing from pool to pool over rectangular weirs. The pools then play a double role: provide rest areas and dissipate the energy of the water descending through the ladder. The size and height of the pools must be designed as a function of the fish to be handled. The pools can be supported by:

- Baffles provided with slots, so that both fish and bedload, pass through them
- Baffles provided with bottom orifices large enough to allow fish to pass
- Baffles provided both with vertical slots and bottom orifices

Pools separated by baffles with bottom orifices only do not have practical interest because are limited to bottom orifice fish swimmers. Salmon do not need them because they can jump over the baffle itself, and shads, for instance, are not bottom swimmers. The system of rectangular weirs (Figure 6) is the oldest one, but presents the inconvenience that when the headwater fluctuates the fish pass flow increases or decreases, resulting in a fish pass with too much or too little flow.





**Figure 7.6: System of rectangular weirs**

Moreover this type of ladder will not pass bedload readily and must be designed with bottom orifices for this purpose. Photo 13 shows one of these ladders with a rustic construction designed for salmon checking on a river in Asturias (Spain).



**Photo 7.13: Fishpass of rustic construction**

Photo 14 illustrates a fish ladder with vertical slots and bottom orifices that usually yields very good results. The shape and disposition of the baffles are shown in perspective in Figure 5 the width of the pools, for lengths varying between 1.8 and 3.0 m, varies from 1.2 m to 2.4 m. The drop between pools is in the order of 10-30 cm. Shads require a drop not bigger than 25 cm. In principle size and drops depend on the species the system is built. Computer programs<sup>7</sup> optimise the width and length of pools, the drop between pools and the hydraulic load.



Photo 7.14: Fishpass with vertical slots

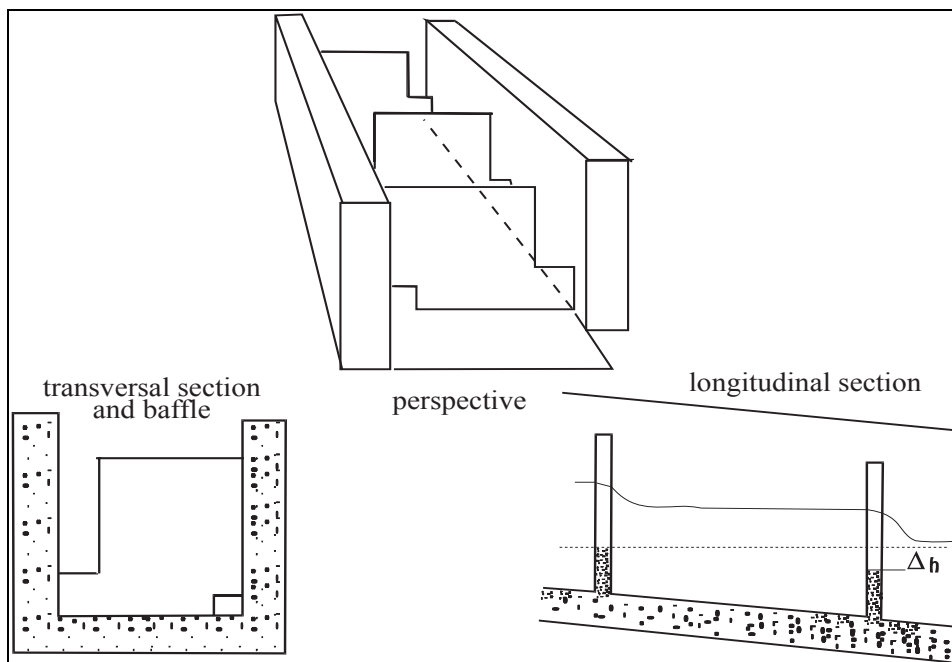
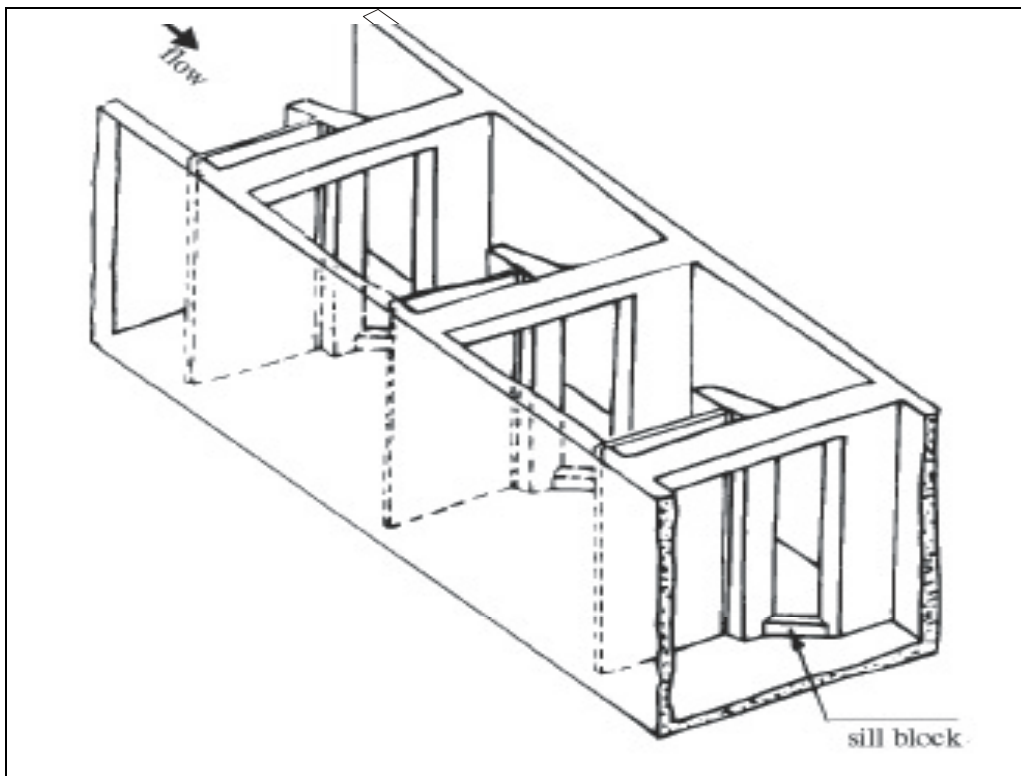


Figure 7.7: Fishpass baffles in section

The vertical slotted fish pass (Figure 8) is very popular in the U.S.A. but not well known in Europe<sup>8</sup>. Through the baffle's vertical slot passes both fishes and bedload. A standard model has pools 2.5-m wide, 3.3 m long with a slot 30 cm wide. Supporters of this type of ladder praise its hydraulic stability even with large flow variations.



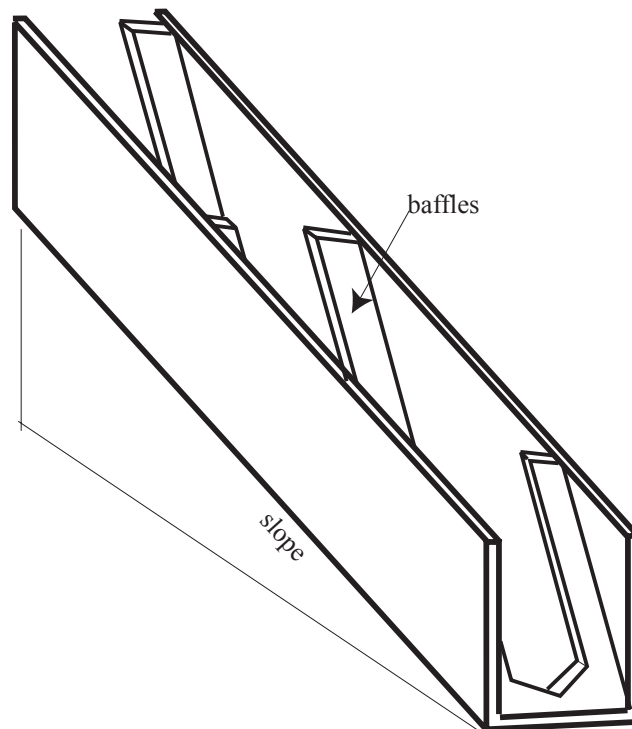
**Figure 7.8: Vertical slotted fish pass**

The Denil fish pass (Photo 15) is steep and consists of narrow chutes with vanes in the bottom and sides as illustrated in Figure. These vanes dissipate the energy providing a low-velocity flow through which the fish can easily ascend.



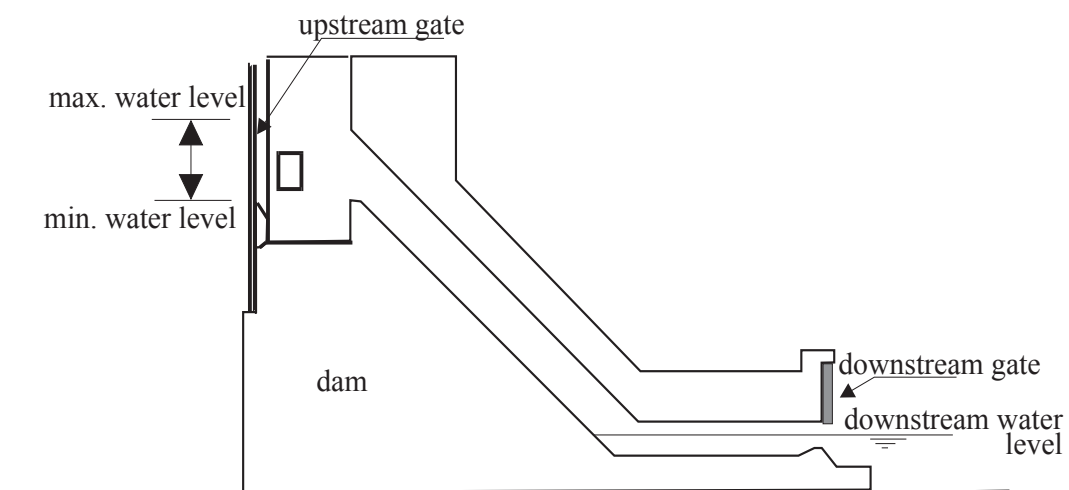
**Photo 7.15: A Denil Fishpass**

This characteristic allows a Denil to be used with slopes up to 1:5. They also produce a turbulent discharge that is more attractive to many fish species than the discharge from pool-type fish passes, and are tolerant of varying water depths. The ladder must be provided with resting areas after approximately 2-m. gain of elevation.



**Figure 7.9: Chutes and Vanes of Denil Fishpass**

The Borland lock (Figure 10) is a relatively cheap solution to transfer fish from the tailrace to the forebay in a medium dam. The fish climb a short fish ladder to the bottom chamber. Then the entrance to the bottom chamber is closed and the shaft rising from it to the top of the dam becomes filled with the water flowing down from the forebay through the top chamber. Once filled, the fish that are attracted by this flow are close to the forebay level into which they can swim.



**Figure 7.10: Section through Borland Lock**

In higher dams, the best solution is to install a lift specifically designed for this purpose. EDF in France has a wide experience with these lifts. The Golfech lift for instance when it was commissioned in 1989 made it possible to pass twenty tonnes of shad (about 66 000 individuals) that were blocked at the base of the dam. Otherwise, the only possible solution is to trap the fish at the base and transport them safely upstream. These devices are discussed in reference<sup>3</sup>. All that is needed is a small fish pass to bring the fish from the tailrace to the trap. There, by mechanical means the fish are concentrated in a trolley hopper, and loaded onto a truck. Eventually the trolley hopper carries them directly over the dam's crest via a cableway and they are discharged into the reservoir.

The most important element of a fish-passage system, and the most difficult to design for maximum effectiveness, is the fish-attraction facility. The fish-attraction facility brings fish into the lower end of the fish-passage and should be designed to take advantage of the tendency of migrating fish to search for strong currents but avoid them if they are too strong. The flow must therefore be strong enough to attract fish away from spillways and tailraces. The flow velocities at the entrance of the fish pass vary with the type of fish being passed, but for salmon and trout, velocities from 2 to 3 m/s are acceptable. A lack of good attraction flow can result in migration delays as the fish become confused and mill around looking for the entrance. If necessary, water must be pumped into the fish pass from the tail water areas, but usually enough water can be taken at the upstream intake or forebay to be directed down the fish pass. When addressing salmon an attraction flow should be maintained between 1 and 2 m/s. If the water is too cold (less than 8°) or too hot (above 22°) then the speed must be decreased as the fish become lazy and do not jump. Water can be injected just at the entrance of the fish pass avoiding the need to transverse all its length (Figure 11)

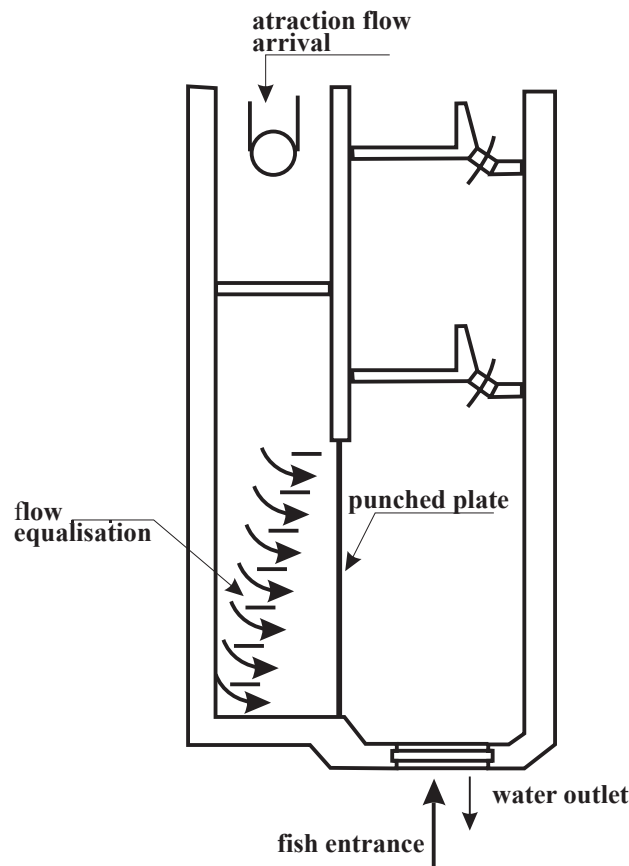
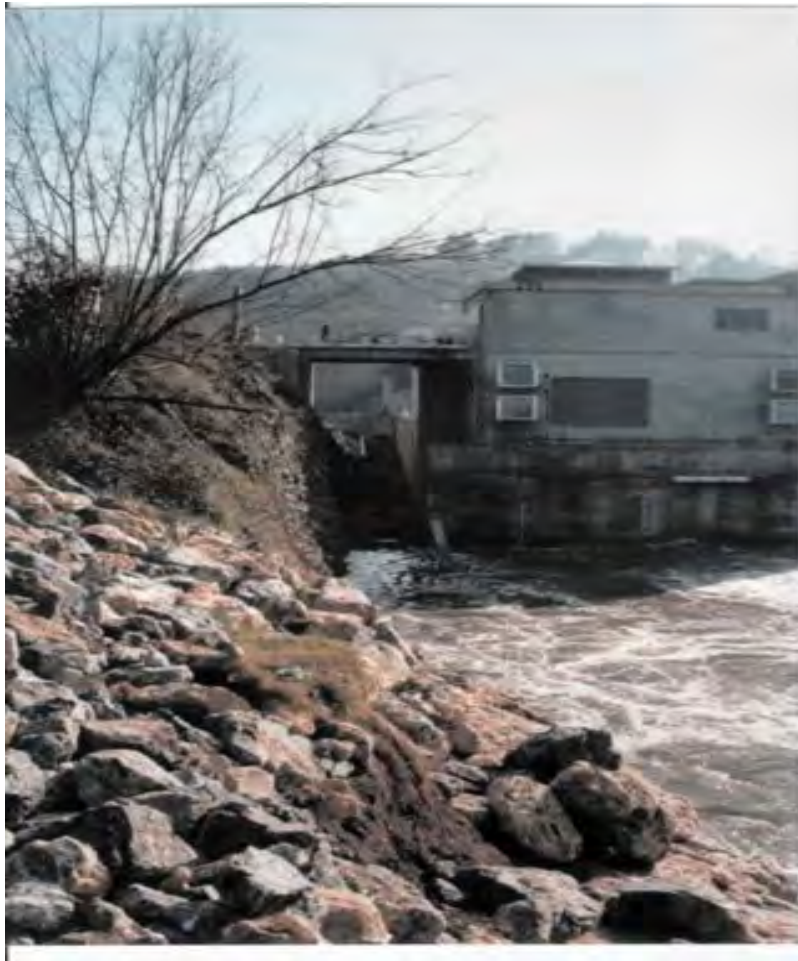


Figure 7.11: Water attraction facility

The entrance to the fish-passage should be located close to the weir since salmon tend to look for the entrance by going around the obstacle. In low-head integrated schemes, the entrance should be in the bank close to the powerhouse as illustrated schematically in Figure 10 and shown in Photo 16.



**Photo 7.16: Powerhouse and fishpass in the left**

The upstream outlet of the fish-passage should not be located in an area close to the spillway, where there is a danger of being sent back to the base of the dam, or in an area of dead circulating waters where the fish can get trapped. Fish-passages must be protected from poachers, either closing it with wire mesh or covering it with steel plates.

The use of fish pumps for fish passage at dams is controversial and largely experimental. This technology is relied upon in aquaculture for moving live fish. Several pumps are in the market and new ones are being developed. Pumping of the fish can lead to injury and de-scaling because of crowding in the bypass pipe.

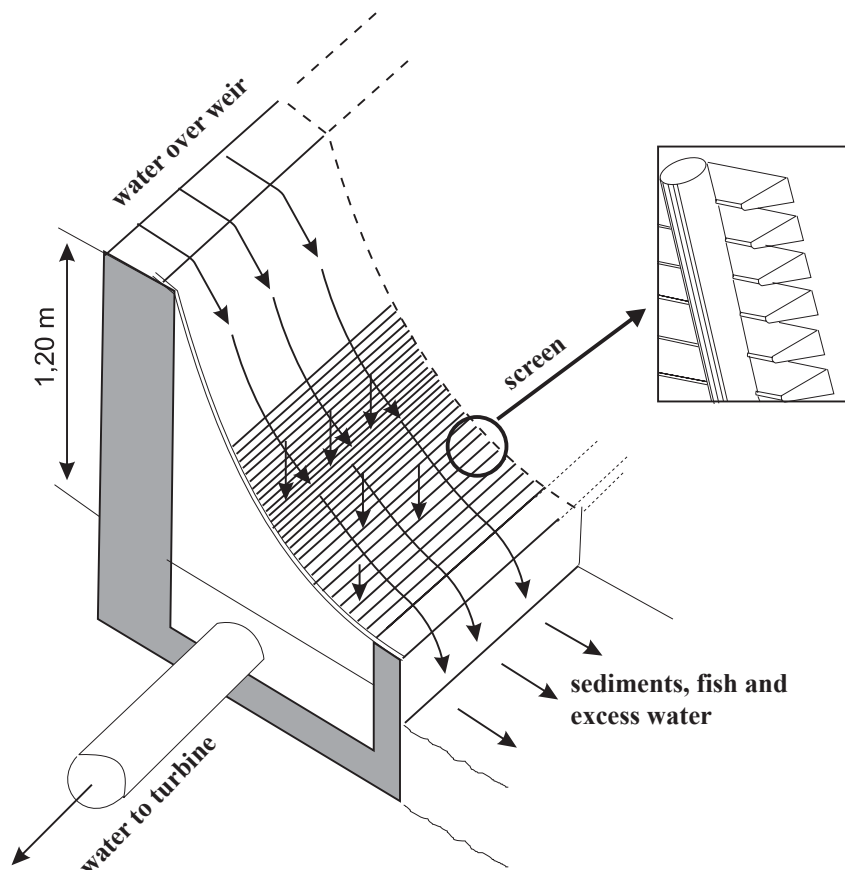
#### 7.4.3.2.7 Fish passes (downstream fish)

In the past downstream migrating fish passed through the turbine. The fish-kill associated with this method varies from a few percent to more than 40% depending on the turbine design and more specifically on the peripheral speed of the runner. In a Francis turbine increasing the peripheral runner speed from 12 m/sec to 30 m/sec increases the percentage mortality from 5% to 35%.

Francis turbines, due to their construction characteristics cause greater mortality than Kaplan turbines. Bulb turbines reduce mortality to less than 5%<sup>9</sup>.

Apparently, head is not a decisive factor. A turbine working at a head of 12 meters produces the same mortality as one working at a head of 120 m. The elevation of the runner above tail water is a very important factor, quite apart from the effect of cavitation. The more efficient a turbine is, the less mortality it produces. A turbine working at rated capacity consequently causes less mortality than one working at partial load. Mechanical injuries by collision against solid bodies - guide vanes or turbine blades, exposure to sub-atmospheric pressures and shear effects produced at the intersections of high velocity flows in opposite directions are the main causes of mortality.

Recently an innovative self-cleaning static intake screen, that does not need power, has been used for fish protection. The screen uses the Coanda<sup>10</sup> effect, a phenomenon exhibited by a fluid, whereby the flow tends to follow the surface of a solid object that is placed in its path. In addition, the V shaped section wire is tilted on the support rods, (Figure 12) producing offsets, which cause a shearing action along the screen surface.



**Figure 7.12 Coanda screen schematic**

The water flows to the collection system of the turbine through the screen slots, which are normally 1 mm wide. Ninety per cent of the suspended solid particles, whose velocity has been increased on the acceleration plate, pass over the screen thus providing excellent protection for the turbine. Aquatic life is also prevented from entering the turbine through the slots. In fact, the smooth surface of the stainless steel screen provides an excellent passageway to a fish bypass. The screen can handle up to 250 l/s per linear meter of screen. A disadvantage of this type of screen is that it requires about 1 to 1.20 m. of head in order to pass the water over the ogee and down into the

collection system. This can be uneconomic in low head systems. Photo 17 shows a Coanda screen<sup>11</sup>.



**Photo 7.17: Coanda Screen in situation**

#### 7.4.3.2.8 Behavioural guidance systems

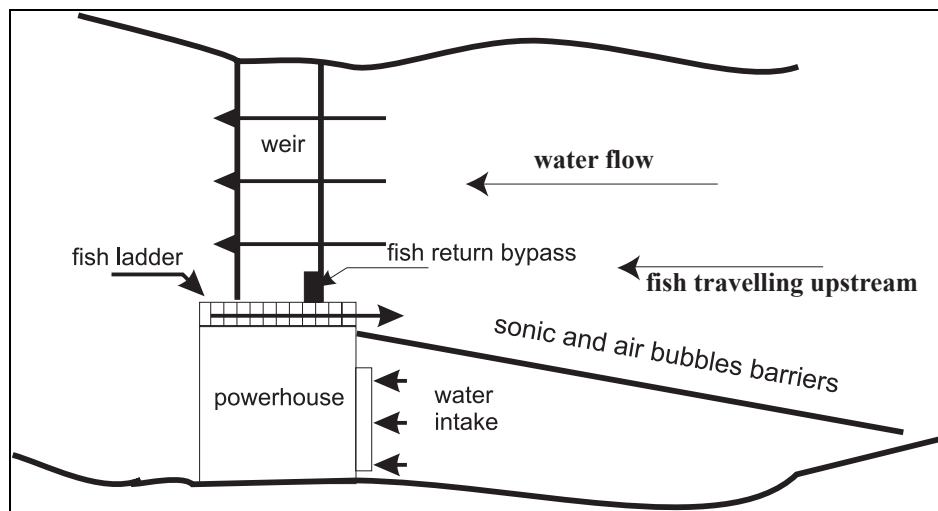
Behavioural guidance systems and a variety of alternative technologies to divert or attract downstream migrants have been the recent object of studies by the Electric Power Research Institute (EPRI). These technologies include strobe lights for repelling fish, mercury lights for attracting fish, a sound generating device known as "hammer" for repelling fish as well as quite a number of electrical guidance systems. It has not yet been demonstrated that these responses can be directed reliably. Behavioural guidance techniques are site and species specific and it appears unlikely that behavioural methods will perform as well as fixed screens over a wide range of hydraulic conditions<sup>12</sup>.

Behavioural screens operate by using the natural response of fish to a stimulus to deflect the fish away from the stimulus. A number of behavioural systems have been tested and acoustic systems have been found to be the most effective systems. For fish to be repelled by a sound, the level of the sound must be high enough to elicit a reaction, taking account of background noise. The background noise issue is important, especially where acoustic systems are deployed near to underwater machinery such as pumps and turbines. The signal types that have proved most effective in all applications are based on artificially generated waveforms that rapidly cycle in amplitude and frequency content, thus reducing habituation. A human equivalent would be being made to stand near to a wailing police or ambulance siren. It simply gets uncomfortable, so you move away! Deflection is usually the best course of action, as the fish are moved swiftly from the source of danger (e.g. water intake) into a safe flow. The BAFF (Bio Acoustic Fish Fence) system produces a "wall of underwater sound" by using compressed air to generate a continuous bubble curtain into which low frequency sound (varying between 50 and 500 Hertz) is injected and entrapped. Although well defined lines of high level sound (at least 160 decibels) are generated within the bubble curtain, the noise levels are negligible a few meters away from it. By restricting



the sound curtain to a small area, the system allows fish to act normally throughout the remainder of the reservoir or river. Figure 13 illustrates the disposition of a system of underwater acoustic transducers, which transmit their sound into a rising bubble curtain to create a wall of sound to guide fish out of the turbine passage.

As manifested by Mr. Turpenney of Fawley Aquatic Research Laboratories Ltd U.K. "the disadvantage of behavioural screens over conventional mechanical screens is that they do not exclude 100% of fish, whereas a mechanical screen of sufficiently small aperture will do so. Typical efficiencies for behavioural barriers range from 50% to 90%, depending upon type and environmental and plant conditions. Most fish penetrating the barrier are likely to go on to pass through the turbine, thereby putting them at risk of injury."



**Figure 7.13: Bio-Acoustic Fish Fence**

Bypass routes must be provided to allow fish to move from the area in front of a physical barrier back to the river.

The screens located at the intake entrance do not need any return conduit because fish are entrained by the water flow and return to the river usually over the spillway. This is of course less dangerous than the turbines, although it also can be damaging. Surprisingly, high spillways are not necessarily more dangerous for fish than low ones. Terminal velocity, as demonstrated by dropping salmon from helicopters into a pond, is reached after about 30 meters of fall, and remains constant thereafter. Eicher mentions an experimental ski-jump spillway, which throws the fish out in free fall to a pool 80m below with a mortality rate reduced to virtually zero.

When the screen is located in the intake downstream of the entrance, a bypass returning the fish to the river is needed. According to behavioural characteristics fish migrating downstream cannot be expected to swim back upstream to find the entrance. This must therefore be located at the downstream end of the screen, assuming the screen is inclined in the direction of the flow. Fish are frequently reluctant to move into small size entrances. A minimum bypass entrance of 45cm is recommended, especially when dealing with juvenile salmonids. It would be preferable that the entrance width could be adjustable by the use of fabricated metal inserts to reduce the size of the opening. The bypass entrance design should provide for smooth flow acceleration into the bypass conduit with no sudden contractions, expansions or bends.

To return fish from the bypass entrance back to the river, fully close conduits or open channels can be used. Fish do not like to enter in conduits with abrupt contrast in lighting. Open channels are better suited for that role. Internal surfaces should be very smooth to avoid fish injury. High density polyethylene and PVC are excellent materials for bypass conduits.

Abrupt changes in section should be avoided due to their associated turbulence and pressure changes. In full flow conduit pressures below atmospheric should be avoided because they can injure or even kill fish. Air entrainment in a full flow conduit generates hydraulic turbulence and surging thus avoiding gas super saturation in the water, which can be detrimental to fish. Conduit discharge velocities should not be too high (relative to the typical velocities in the outfall) so as to create shear forces that can injure fish. Velocities close to 0.8 m/sec are recommended.

#### **7.4.3.3 In the terrain**

Open canals may sometimes be an obstacle to the free passage of animals. To avoid this, nowadays open canals are entirely buried and even repopulated with vegetation so they do not represent any barrier. In contradiction, the burial of the water conveyance structure is said to be a loss of aquatic habitat for several purposes. It is reported that sometimes animals may fall into an open canal without any chance to get out due to a rectangular cross section. Certain ladder constructions may serve effectively at rather low cost. Other construction work in connection with SHP will not be an ecological impact worth mentioning.

#### **7.4.3.4 Trashrack material**

Almost all small hydroelectric plants have a trash rack cleaning machine, which removes material from water in order to avoid it entering plant waterways and damaging electromechanical equipment or reducing hydraulic performance. Each year tons of material (typically plastic bags, bottles, cans and other kinds of things man and as well as carcasses, leaves and natural detritus also found in the water) are removed from the water stream.

In many countries, once a thing, including organic material (leaves, branches and so on) is removed from the main stream, it becomes automatically waste material. When this is the case it cannot be thrown back into the water but must be properly disposed often at very high costs.

With this being the case, it is clear that small hydroelectric plants play a fundamental role in cleaning the river environment. This benefit to the river is often unacknowledged but clearly represents a positive impact by the small hydroelectric plants and it should be duly taken into account. Suitable support measures should be undertaken to reduce the economic burdens on small hydroelectric plants operators regarding this matter (e.g. by reducing the waste disposal fees or allowing for different treatment between organic and not-organic material).

### **7.5 Impacts from transmission lines**

#### **7.5.1 Visual impact**

Above ground transmission lines and transmission line corridors can have a negative impact on the landscape. These impacts can be mitigated by adapting the line to the landscape, or in extreme cases burying it.



**Photo 7.18 Visual impact of outdoors substation**

The optimal technical and economic solution for a transmission line routing is that which will often create the more negative aesthetic impacts. To achieve optimal clearance from the ground the pylons are placed on the top of the hills, constituting a very dominating element of the landscape. A minimum of bends in the route will reduce the number of angle and ordinary pylons and therefore reduce its cost. Aesthetically neither a high frequency of bends, nor straight routes that are made without consideration for the terrain and landscape factors are preferred.

In sensitive mountain areas where schemes are developed, transmission lines can dominate the landscape and therefore influence the beauty of the scenario. It must be remarked that transmission lines exist even without the existence of hydropower schemes. Villages even if they are high in the mountain require electricity to make life liveable, and electricity, unless generated by photovoltaic systems, requires transmission lines. It is true that with a right siting of the lines in relation to larger landscape forms and a careful design of the pylons the impact can be relatively mitigated. Other times, as in Cordinanes, the transformer substation and transmission lines are concealed from public view and the situation much improved, but it is an expensive solution that only can be offered if the scheme is profitable enough.

#### 7.5.2 Health impact

In addition to the visual intrusion, some people may dislike walking under transmission lines because of the perceived risks of health effects from electromagnetic fields. Apart from the fact that this risk is only perceived in high voltage transmission lines, and never is the case in a small hydropower scheme, after several years of contradictory reports there is still no final result.

### 7.6 Conclusion

In the last two decades a huge number of newly developed sites demonstrate that even under highly restrictive environmental conditions the peaceful and sustainable coexistence of small hydropower and the environment is possible. In SHP, it is much easier to meet environmental demands than in the field of big hydropower, where technical concerns are rather less flexible. Although the

exploitation of SHP is not in principle free of environmental problems, the wide range of effective mitigating measures offers many worthwhile approaches for the responsible, open-minded, and experienced designer. SHP and the protection of the environment are not a contradiction but an extraordinary interesting and exiting challenge.

---

<sup>1</sup> By Bernhard Pelikan (ÖVFK), Luigi Papetti (Studio Frosio) and Celso Penche (ESHA)

<sup>2</sup> European Commission - "Externalities of Energy - Volume 6 Wind and Hydro" EUR 16525 EN

<sup>3</sup> S. Palmer. "Small scale hydro power developments in Sweden and its environmental consequences". HIDROENERGIA 95 Proceedings. Milano

<sup>4</sup> F. Monaco, N. Frosio, A. Bramati, "Design and realisation aspects concerning the recovery of an energy head inside a middle European town" HIDROENERGIA 93, Munich

<sup>5</sup> J. Gunther, H.P. Hagg, "Vollständig Überflutetes Wasserkraftwerk Karlstor/Heidelberg am Neckar", HIDROENERGIA 93, Munich

<sup>6</sup> European Commission - "Externalities of Energy - Volume 6 Wind and Hydro" EUR 16525 EN.

<sup>7</sup> Santos Coelho & Betamio de Almeida, "A computer assisted technique for the hydraulic design of fish ladders in S.H.P." HIDROENERGIA 95, Munich

<sup>8</sup> J Osborne . New Concepts in Fish Ladder Design (Four Volumes), Bonneville Power Administration, Project 82-14, Portland, Oregon, 1985

<sup>9</sup> Department of Energy, Washington, USA. "Development of a More Fish-Tolerant Turbine Runner" (D.O.E./ID.10571)

<sup>10</sup> Dulas Ltd. Machynllyth, Powys, Wales SY20 8SX. e-mail dulas@gn.apc.org "Static screening systems for small hydro". HIDROENERGIA97 Conference Proceedings, page 190

<sup>11</sup> James J. Strong. "Innovative static self-cleaning intake screen protects both aquatic life and turbine equipment" HYDRO88 Conference papers.

<sup>12</sup> D.R. Lambert, A. Turpenny, J.R. Nedwell "The use of acoustic fish deflection systems at hydro stations", Hydropower & Dams Issue One 1997

## **CHAPTER 8: ECONOMIC ANALYSIS**

### **CONTENTS**

8 ECONOMIC ANALYSIS .....	237
8.1 Introduction .....	237
8.2 Basic considerations .....	237
8.3 Time value of Money .....	239
8.4 Methods of economic evaluation.....	242
8.4.1. Static methods.....	243
8.4.2 Dynamic methods .....	244
8.4.3 Examples.....	246
8.5 Tariffs and Incentives .....	252

### **LIST OF FIGURES**

Figure 8.1: Specific cost of installed capacity .....	238
Figure 8.2: Investment costs for installed capacity for specific heads .....	238
Figure 8.3: ESTIR turnkey investment costs for small hydro .....	239

### **LIST OF TABLES**

Table 8.1: Present Value Factor (PVF) for various time periods' n and opportunity cost r.....	242
Table 8.2: Cash flow analysis.....	248
Table 8.3: NPV against discount rate and lifetime .....	249
Table 8.4: Rb/c against discount rate and lifetime .....	249
Table 8.5: NPV, Rb/c and IRR for different tariffs (were r is 8% and the period is 35 years) .....	250
Table 8. 6: Example B – Annual cashflows for externally financed investment .....	251
Table 8.7: Financial analysis of real schemes in Europe.....	252
Table 8.8: Prices for SHP generation in the European Union Member States.....	253

## **8 ECONOMIC ANALYSIS**<sup>1</sup>

### **8.1 Introduction**

An investment in a small hydropower scheme entails a certain number of expenses, extended over the project life, and procures some revenues also distributed over the same period. The expenses include a fixed component - the capital cost, insurance, taxes other than the income taxes, etc- and a variable component -operation and maintenance expenses-. At the end of the project, in general limited by the authorisation period, the residual value will usually be positive, although some administrative authorisations demand the abandonment of all the facilities that revert to the State. The economic analysis compares the different possible alternatives to allow the choice of the most advantageous or to abandon the project.

From an economic viewpoint, a hydropower plant differs from a conventional thermal plant, because its initial investment cost per kW is much higher but the operating costs are extremely low, since there is no need to pay for fuel.

The economic analysis can be made by either including the effect of the inflation or omitting it. Working in constant monetary value has the advantage of making the analysis essentially independent of the inflation rate. Value judgements are easier to make in this way because they refer to a nearby point in time, which means they are presented in a currency that has a purchasing power close to present experience. If there are reasons to believe that certain factors will evolve at a different rate from inflation, these must be treated with the differential inflation rate. For instance, if we assume that due to the electricity tariffs will grow two points less than inflation, while the remaining factors stay constant in value, the electricity price should decrease by 2% every year.

### **8.2 Basic considerations**

The estimation of the investment cost constitutes the first step of an economic evaluation. For a preliminary approach, the estimation can be based on the cost of similar schemes: IDAE (Instituto para la Diversificación y Ahorro de Energía, Spain) in its publication "Minicentrales Hidroeléctricas"<sup>2</sup> analyses the cost of the different components of a scheme - weir, water intake, canal, penstock, powerhouse, turbines and generators, transformers and transmission lines. J. Fonkenelle also published monograms, but only for low-head schemes<sup>3</sup>. The Departamento Nacional de Aguas e Energia Eléctrica (DNAEE) developed a computer program, FLASH, for small hydro feasibility studies<sup>4</sup>.

There are a number of software packages available to assist in the analysis of a potential site. PC based packages such as HydrA<sup>5</sup> and Hydrossoft<sup>6</sup> are available on the Web and can often be downloaded. Some of them are limited to particular regions or countries whilst others are more generic. The RETScreen Pre-feasibility Analysis Software<sup>7</sup> is a generic, freely available software package with an on-line user manual. It enables users to prepare a preliminary evaluation of the annual energy production, costs and financial viability of projects.

Whilst identifying that the site has a technical potential is paramount, the key to any successful development is undertaking an economic analysis of a site that will provide an accurate indication of the investment cost required. During this analysis an essential consideration is the estimated cost per kW of the site.

In his communication to HIDROENERGIA'97 on the THERMIE programme, H. Pauwels from DG TREN, former DG XVII showed. It summarises data from schemes presented to the above programme and correlates the investment cost in €/kW installed for different power ranges and heads. Perhaps not surprisingly two characteristics become clear from this graph: costs increase as head decreases and similarly as scheme kW size decreases also. The conclusion being that small (less than 250kW), low head (less than 15m) schemes represent the highest relative costs for a scheme.

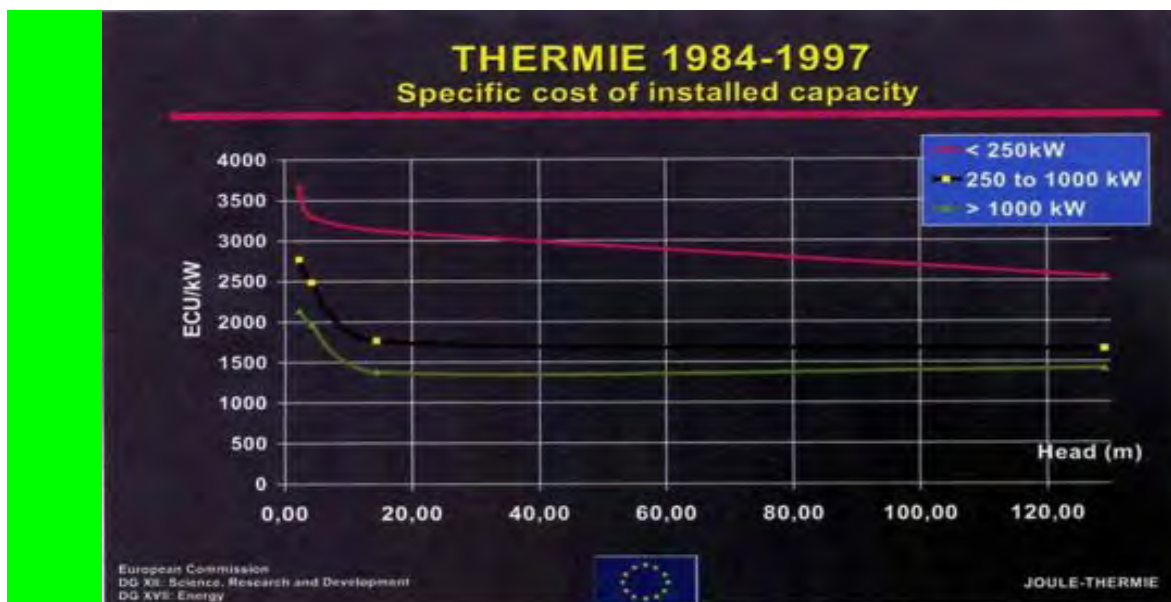


Figure 8.1: Specific cost of installed capacity

Also presented at HIDROENERGIA '97 from the computer program, Hydrosoft, was the set of curves in correlating the investment cost in €/kW and the installed capacity (between 100 kW and 10 MW) for low head schemes, with 2, 3, 4 and 5 m head.

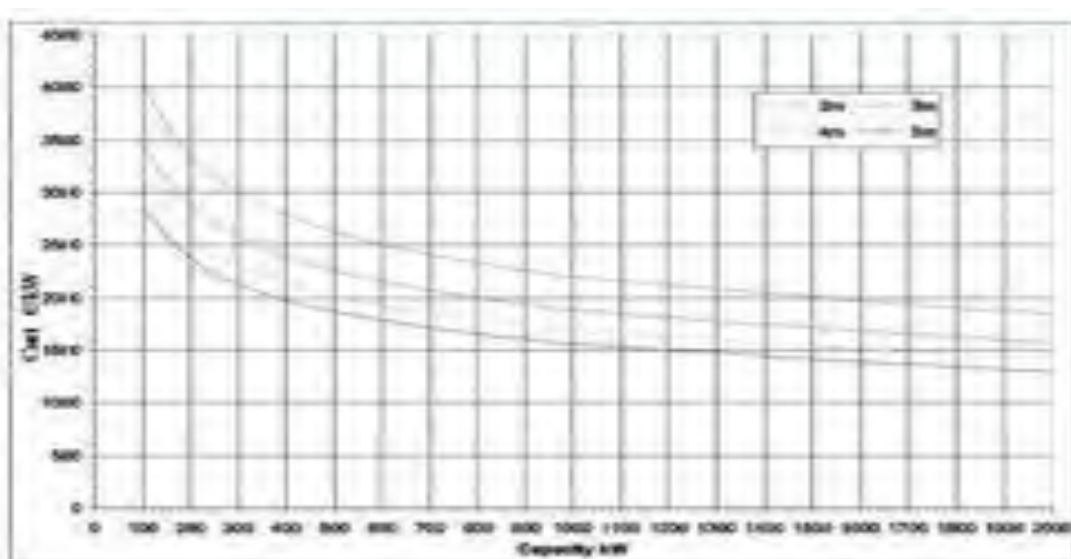
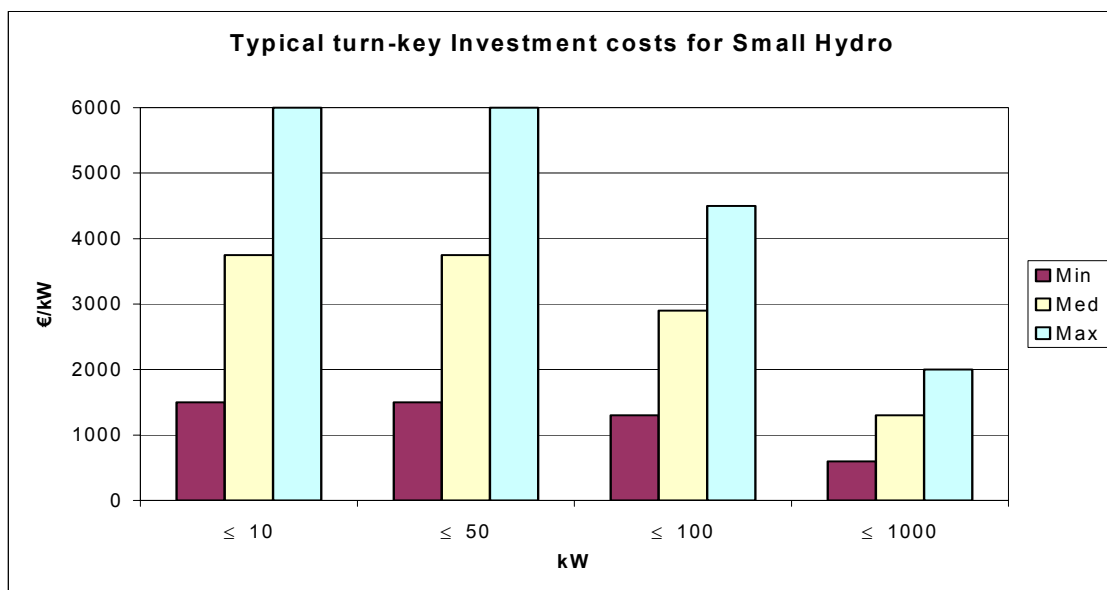


Figure 8.2: Investment costs for installed capacity for specific heads

More recent figures from ESTIR<sup>8</sup>, December 2002, show investment costs specific to small hydro and scheme kW size (but does not relate to head). These costs have quite a range and are shown in.



**Figure 8.3: ESTIR turnkey investment costs for small hydro**

These figures suggest that in the smaller kW range end investment costs can be as high as 6000 €/kW in extreme cases.

However, as a cost estimate is essential for economic analysis, it is necessary as a second step, to make a preliminary design including the principal components of the scheme. Based on this design, budget prices for the materials can be obtained from suppliers. Such prices cannot be considered as firm prices until specifications and delivery dates have been provided. This will come later, during the actual design and procurement process.

Do not forget that in a plant connected to the grid, the investment costs of the connection line should be included, because according to various national regulations this line, although it sometimes becomes the property of the grid owner, is always built at the expense of the SHP developer. A plant close to the grid connection point will be always cheaper than one installed far from it. The same reasoning can be applied to telephone lines. In an unmanned plant, a telephone line to transmit telemetry and alarm signals is frequently used although occasionally it might be cheaper to use the transmission line itself to establish a radio link. The use of the digital cellular telephone network is also increasingly used provided there is sufficient coverage.

### 8.3 Time value of Money

The ‘time value of money’ is the concept that a Euro received today is worth more than a Euro received at some point in the future, because the Euro received today can be invested to earn interest. Time value of money analysis generally involves the relationship between a certain amount of money, a certain period and a certain rate of compound interest.

An investment project considers revenues and expenses that take place in very different time periods. In any economic analysis involving economic value there are always two variables, money



and time. A certain amount of money paid or received at a point in time has a different value if it is paid or received at another point in time. Money can be invested during a certain period of time with the guarantee of a certain benefit. The term ‘present value’ stands for the current value of a future amount of money or a series of payments, evaluated at a given interest rate. In order to determine the present value (PV) of a future amount of money or future value (FV), discounted at a given interest rate “r” (also called discounted rate), for a number of years “n”, the following formula is used:

$$PV_0 = \frac{FV_n}{(1+r)^n} = \frac{1}{(1+r)^n} FV_n \quad (8.1)$$

The term  $1/(1+r)^n$  is called “present value factor” (PVF). Table 8.1 gives the value of this multiplier for different interest rates and time periods. Therefore, for a discounting rate r, the cost  $C_n$  (or the benefit  $B_n$ ), disbursed or received in the year n, is discounted to the year zero by the equation:

$$C_0 = \left[ \frac{1}{(1+r)^n} \right] C_n \quad (8.2)$$

The fraction within square brackets is ‘present value factor’. To find the comparable value of a given sum of money if it were received, or disbursed, at a different time, the above formula may be used or the corresponding PVF as given in left hand columns of Table 8.1 may be multiplied by the given sum. For instance, if the investor's opportunity earning potential were 8%, €1500 to be received in 5 years from now would be equivalent to receiving now,

$$\left[ \frac{1}{(1+0.08)^5} \right] 1500 = \text{€}1\,020.9$$

Cash flows occurring at different times can be converted to a common basis, using the discount method, either using the formulae, available on an electronic spreadsheet, or the Table 8.1. In Table 8.1, the discount factors are calculated from the discount formulas for various time periods and opportunity costs (expressed as rate of discount r). The time periods can be years, quarters, months etc. and the periodic discount rate will be the corresponding to the period (if r is the annual discount rate, r/4 will be the discount rate corresponding to a quarter and 1/12r the corresponding rate for one month).

With the concept of present value for a future payment, investors can calculate the present value of the future sales price of a SHP plant. The formula is useful in understanding that an investment today has to be sold at a much higher price in the future if the investment is to be interesting from an economic point of view. Although the PVF could be used to solve any present value problem that would arise, it is convenient to define a second term in order to speed the arithmetic process: the present value of an annuity. An annuity is a series of equal payments over a certain period of time. The present value of an annuity over n years, with an annual payment C (starting at the end of the first year) will be the result of multiplying C by a factor,  $a_n$ , equal to the sum of present value factors, PVF’s (v):

$$a_n = v^1 + v^2 + v^3 \dots + v^n$$

It can be demonstrated that,

$$a_n = \frac{1 - v_n}{r} = \frac{(1+r)^n - 1}{r(1+r)^n} = \frac{1 - (1+r)^{-n}}{r} \quad (8.3)$$

Annuities are payments occurring regularly over a period of time “n”. With “C” being the annual payment and “PVA” the present value of the annuity, we can express the present value as the sum of future payments discounted at “r”:

$$PVA_n = C \left[ \sum_{t=1}^n \frac{1}{(1+r)^t} \right] = C \frac{1 - \frac{1}{(1+r)^n}}{r} = C \frac{1 - (1+r)^{-n}}{r} = C * a_n \quad (8.4)$$

For instance, the present value of a series of €200 payments over three years, beginning at the end of the first year, will be given by using equation 8.4 and the PVF of the right hand columns in Table 8.1. Assuming a discount rate, r, of 8% then:

$$PVA_3 = 200 \left[ \sum_{t=1}^3 \frac{1}{(1+0.08)^t} \right] = 200 \frac{1 - \frac{1}{(1+0.08)^3}}{0.08} = 200 \frac{1 - (1+0.08)^{-3}}{0.08} = 200 * 2.5771 = 515.42€$$

The concept of present value of an annuity allows the evaluation of how much the annual sales revenue from the SHP plant electricity is worth to the investor. With electricity sales price of 4€cts/kWh and a yearly production of 100000 kWh, revenue per year (the annuity) is 4000€. What would be the value of this revenue stream over 10 years at present for a required return of 8% for the investor? Again, applying formula 8.4 and table 8.1 values:

$$PVA_{10} = 4000 \frac{1 - \frac{1}{(1+0.08)^{10}}}{0.08} = 4000 * 6.7101 = 26840.4€$$

**Table 8.1: Present Value Factor (PVF) for various time periods' n and opportunity cost r**

n/r	Single payment				Uniform series of payments			
	6%	8%	10%	12%	6%	8%	10%	12%
1	0.9434	0.9259	0.9091	0.8929	0.9434	0.9259	0.9091	0.8929
2	0.8900	0.8573	0.8264	0.7972	1.8334	1.7833	1.7355	1.6901
3	0.8396	0.7938	0.7513	0.7118	2.6730	2.5771	2.4869	2.4018
4	0.7921	0.7350	0.6830	0.6355	3.4651	3.3121	3.1699	3.0373
5	0.7473	0.6806	0.6209	0.5674	4.2124	3.9927	3.7908	3.6048
6	0.7050	0.6302	0.5645	0.5066	4.9173	4.6229	4.3553	4.1114
7	0.6651	0.5835	0.5132	0.4523	5.5824	5.2064	4.8684	4.5638
8	0.6274	0.5403	0.4665	0.4039	6.2098	5.7466	5.3349	4.9676
9	0.5919	0.5002	0.4241	0.3606	6.8017	6.2469	5.7590	5.3282
10	0.5584	0.4632	0.3855	0.3220	7.3601	6.7101	6.1446	5.6502
11	0.5268	0.4289	0.3505	0.2875	7.8869	7.1390	6.4951	5.9377
12	0.4970	0.3971	0.3186	0.2567	8.3838	7.5361	6.8137	6.1944
13	0.4688	0.3677	0.2897	0.2292	8.8527	7.9038	7.1034	6.4235
14	0.4423	0.3405	0.2633	0.2046	9.2950	8.2442	7.3667	6.6282
15	0.4173	0.3152	0.2394	0.1827	9.7122	8.5595	7.6061	6.8109
16	0.3936	0.2919	0.2176	0.1631	10.1059	8.8514	7.8237	6.9740
17	0.3714	0.2703	0.1978	0.1456	10.4773	9.1216	8.0216	7.1196
18	0.3503	0.2502	0.1799	0.1300	10.8276	9.3719	8.2014	7.2497
19	0.3305	0.2317	0.1635	0.1161	11.1581	9.6036	8.3649	7.3658
20	0.3118	0.2145	0.1486	0.1037	11.4699	9.8181	8.5136	7.4694
21	0.2942	0.1987	0.1351	0.0926	11.7641	10.0168	8.6487	7.5620
22	0.2775	0.1839	0.1228	0.0826	12.0416	10.2007	8.7715	7.6446
23	0.2618	0.1703	0.1117	0.0738	12.3034	10.3711	8.8832	7.7184
24	0.2470	0.1577	0.1015	0.0659	12.5504	10.5288	8.9847	7.7843
25	0.2330	0.1460	0.0923	0.0588	12.7834	10.6748	9.0770	7.8431
26	0.2198	0.1352	0.0839	0.0525	13.0032	10.8100	9.1609	7.8957
27	0.2074	0.1252	0.0763	0.0469	13.2105	10.9352	9.2372	7.9426
28	0.1956	0.1159	0.0693	0.0419	13.4062	11.0511	9.3066	7.9844
29	0.1846	0.1073	0.0630	0.0374	13.5907	11.1584	9.3696	8.0218
30	0.1741	0.0994	0.0573	0.0334	13.7648	11.2578	9.4269	8.0552
31	0.1643	0.0920	0.0521	0.0298	13.9291	11.3498	9.4790	8.0850
32	0.1550	0.0852	0.0474	0.0266	14.0840	11.4350	9.5264	8.1116
33	0.1462	0.0789	0.0431	0.0238	14.2302	11.5139	9.5694	8.1354
34	0.1379	0.0730	0.0391	0.0212	14.3681	11.5869	9.6086	8.1566
35	0.1301	0.0676	0.0356	0.0189	14.4982	11.6546	9.6442	8.1755
36	0.1227	0.0626	0.0323	0.0169	14.6210	11.7172	9.6765	8.1924
37	0.1158	0.0580	0.0294	0.0151	14.7368	11.7752	9.7059	8.2075
38	0.1092	0.0537	0.0267	0.0135	14.8460	11.8289	9.7327	8.2210
39	0.1031	0.0497	0.0243	0.0120	14.9491	11.8786	9.7570	8.2330
40	0.0972	0.0460	0.0221	0.0107	15.0463	11.9246	9.7791	8.2438

#### **8.4 Methods of economic evaluation**

While the payback period method is the easiest to calculate most accountants would prefer to look at the net present value and the internal rate of return. These methods take into consideration the greatest number of factors, and in particular, they are designed to allow for the time value of money.

When comparing the investments of different projects the easiest method is to compare the ratio of the total investment to the power installed or the ratio of the total investment to the annual energy

produced for each project. This criterion does not determine the profitability of a given scheme because the revenue is not taken into account and constitutes a first evaluation criterion.

#### 8.4.1. Static methods

##### 8.4.1.1 Payback method

The payback method determines the number of years required for the invested capital to be offset by resulting benefits. The required number of years is termed the payback, recovery, or break-even period. The calculation is as follows:

$$\text{Payback period} = \frac{\text{investment cost}}{\text{net annual revenue}}$$

The measure is usually neglecting the opportunity cost of capital. The opportunity cost of capital is the return that could be earned by using resources for an alternative investment purpose rather than for the purpose at hand. Investment costs are usually defined as first costs (civil works, electrical and hydro mechanical equipment) and benefits are the resulting net yearly revenues expected from selling the electricity produced, after deducting the operation and maintenance costs, at constant value money. The payback ratio should not exceed 7 years if the small hydro project is to be considered profitable.

However, the payback does not allow the selection from different technical solutions for the same installation or choosing among several projects that may be developed by the same promoter. In fact it does not consider cash flows beyond the payback period and thus does not measure the efficiency of the investment over its entire life.

Under the payback method of analysis, projects or purchases with shorter payback periods rank higher than those with longer paybacks do. The theory is that projects with shorter paybacks are more liquid, and thus represent less of a risk.

For the investor, when using this method is more advisable to accept projects that recover the investment and if there is a choice, select the project, which pays back soonest. This method is simple to use but it is attractive if liquidity is an issue but does not explicitly allow for the “time value of money” for investors.

##### 8.4.1.2 Return on investment method

The return on investment (ROI) calculates average annual benefits, net of yearly costs, such as depreciation, as a percentage of the original book value of the investment. The calculation is as follows:

$$ROI = \frac{\text{net annual revenue} - \text{depreciation}}{\text{investment cost}} \times 100$$

For purposes of this formula, depreciation is calculated very simply, using the straight-line method:

$$\text{Depreciation} = \frac{\text{cost} - \text{salvage value}}{\text{operational life}}$$

Using ROI can give you a quick estimate of the project's net profits, and can provide a basis for comparing several different projects. Under this method of analysis, returns for the project's entire useful life are considered (unlike the payback period method, which considers only the period that it takes to recoup the original investment). However, the ROI method uses income data rather than cash flow and it completely ignores the time value of money. To get around this problem, the net present value of the project, as well as its internal rate of return should be considered.

#### 8.4.2 Dynamic methods

These methods of financial analysis take into account total costs and benefits over the life of the investment and the timing of cash flows.

##### **8.4.2.1 Net Present Value (NPV) method**

NPV is a method of ranking investment proposals. The net present value is equal to the present value of future returns, discounted at the marginal cost of capital, minus the present value of the cost of the investment. The difference between revenues and expenses, both discounted at a fixed, periodic interest rate, is the net present value (NPV) of the investment, and is summarised by the following steps:

1. Calculation of expected free cash flows (often per year) that result out of the investment
2. Subtract /discount for the cost of capital (an interest rate to adjust for time and risk) giving the Present Value
3. Subtract the initial investments giving the Net Present Value (NPV)

Therefore, net present value is an amount that expresses how much value an investment will result in, in today's monetary terms. Measuring all cash flows over time back towards the current point in present time does this. A project should only be considered if the NPV results in a positive amount.

The formula for calculating NPV, assuming that the cash flows occur at equal time intervals and that the first cash flows occur at the end of the first period, and subsequent cash flow occurs at the ends of subsequent periods, is as follows:

$$NPV = \sum_{i=1}^{i=n} \frac{R_i - (I_i + O_i + M_i)}{(1+r)^i} + V_r \quad (8.5)$$

Where,

$I_i$  = investment in period  $i$

$R_i$  = revenues in period  $i$

$O_i$  = operating costs in period  $i$

$M_i$  = maintenance costs in period  $i$

$V_r$  = residual value of the investment over its lifetime, where equipment lifetime exceeds the plant working life

$r$  = periodic discount rate, where the period is a quarter, the periodic rate is  $\frac{1}{4}$  of the annual rate

$n$  = number of lifetime periods e.g. years, quarters, months etc.

The calculation is usually done for a period of thirty years, because due to the discounting techniques used in this method, both revenues and expenses become negligible after a larger number of years.

Different projects may be classified in order of decreasing NPV. Projects where NPV is negative will be rejected, since that means their discounted benefits during the lifetime of the project are insufficient to cover the initial costs. Among projects with positive NPV, the best ones will be those with greater NPV.

The NPV results are quite sensitive to the discount rate, and failure to select the appropriate rate may alter or even reverse the efficiency ranking of projects. Since changing the discount rate can change the outcome of the evaluation, the rate use should be considered carefully. For a private developer, the discount rate will be such that will allow him to choose between investing on a small hydro project or keep his saving in the bank. This discount rate, depending on the inflation rate, usually varies between 5% and 12%.

If the net revenues are constant in time (uniform series), their discounted value is given by the equation (8.3).

The method does not distinguish between projects with high investment costs promising a certain profit, from another that produces the same profit but needs a lower investment, as both have the same NPV. Hence a project requiring €1 000 000 in present value and promises €1 100 000 profit shows the same NPV as another one with a €100 000 investment and promises €200 000 profit (both in present value). Both projects will show a €100 000 NPV, but the first one requires an investment ten times higher than the second does.

There has been some debate<sup>9</sup> regarding the use of a constant discount rate when calculating the NPV. Recent economic theory suggests the use of a declining discount rate is more appropriate for longer-term projects – those with a life-span over thirty years and in particular infrastructure projects. Examples of these could be climate change prevention, construction of power plant and the investment in long-term infrastructure such as roads and railways. Taking Climate Change as an illustrative example, mitigation costs are incurred now with the benefits of reduced emissions only becoming apparent in the distant future. When using a constant discount rate these benefits are discounted to virtually zero providing little incentive, however the declining discount rate places a greater emphasis on the future benefits.

In summary, correct use of a declining discount rate places greater emphasis on costs and benefits in the distant future. Investment opportunities with a stream of benefits accruing over a long project lifetime therefore appear more attractive.

### 8.4.2.2 Benefit-Cost ratio

The benefit-cost method compares the present value of the plant benefits and investment on a ratio basis. It compares the revenue flows with the expenses flow. Projects with a ratio of less than 1 are generally discarded. Mathematically the  $R_{b/c}$  is as follows:

$$R_{b/c} = \frac{\sum_0^n \frac{R_n}{(1+r)^n}}{\sum_0^n \frac{(I_n + M_n + O_n)}{(1+r)^n}} \quad (8.6)$$

where parameters are the same as stated in (8.5)

### 8.4.2.3 Internal Rate of Return method

The internal rate of return (IRR) method of analysing a major project allows consideration of the time value of money. Essentially, it determines the interest rate that is equivalent to the Euro returns expected from the project. Once the rate is known, it can be compared to the rates that could be earned by investing the money in other projects or investments.

If the internal rate of return is less than the cost of borrowing used to fund your project, the project will clearly be a money-loser. However, usually a developer will insist that in order to be acceptable, a project must be expected to earn an IRR that is at least several percentage points *higher* than the cost of borrowing. This is to compensate for the risk, time, and trouble associated with the project.

The criterion for selection between different alternatives is normally to choose the investment with the highest rate of return.

A process of trial and error, whereby the net cash flow is computed for various discount rates until its value is reduced to zero, usually calculates the rate of the return. Electronic spreadsheets use a series of approximations to calculate the internal rate of return. The following examples illustrate how to apply the above-mentioned methods to a hypothetical small hydropower scheme:

#### 8.4.3 Examples

##### 8.4.3.1 Example A

**Installed capacity:** 4 929 kW

**Estimated annual output** 15 750 MWh

**First year annual revenue** €1 005 320

It is assumed that the price of the electricity will increase every year one point less than the inflation rate.

The estimated cost of the project in € is as follows:

1. Feasibility study	6 100
2. Project design and management	151 975
3. Civil works	2 884 500
4. Electromechanical equipment	2 686 930
5. Installation	686 930
Sub-Total	6 416 435
Unforeseen expenses (3%)	192 493
<b>Total investment</b>	<b>€6 608 928</b>

The investment cost per installed kW would be:

$$6\,608\,928 / 4\,929 = 1\,341 \text{ €/kW}$$

The investment cost per annual MWh produced is: 420 €/MWh

The operation and maintenance cost per year, estimated at 4% of the total investment, is: €264 357

In the analysis, it is assumed that the project will be developed in four years. The first year will be devoted to the feasibility study and to application for the authorisation. Hence, at the end of first year, both the entire feasibility study cost and half the cost of project design and management will be charged. At the end of second year the other half of the design and project management costs will be charged. At the end of the third year 60% of the civil works will be finished and 50% of the electromechanical equipment paid for. At the end of the fourth year the whole development is finished and paid. The scheme is commissioned at the end of the fourth year and becomes operative at the beginning of the fifth (year zero). The electricity revenues and the O&M costs are made effective at the end of each year. The electricity prices increases by one point less than the inflation rate. The water authorisation validity time has been fixed at 35 years, starting from the beginning of the second year (year -2). The discount rate is 8% and the residual value nil. Table .2 shows the cash flows along the project lifetime.



Table 8.2: Cash flow analysis

<b>Investment cost - €</b>	<b>O&amp;M costs - €</b>	<b>Discount rate - r</b>	<b>Lifetime - n</b>
<b>6 608 928</b>	<b>264 357</b>	<b>8%</b>	<b>35 yr.</b>

Year	Investment	Revenues	O&M	Cash Flow	Cumulated Cash Flow
-4	82 087			- 82 087	- 82 087
-3	75 988			- 75 988	- 158 075
-2	3 074 165			-3 074 165	-3 232 240
-1	3 376 688			-3 376 688	-6 608 928
0		1 005 320	264 357	740 963	-5 867 965
1		995 267	264 357	730 910	-5 137 055
2		985 314	264 357	720 957	-4 416 098
3		975 461	264 357	711 104	-3 704 995
4		965 706	264 357	701 349	-3 003 645
5		956 049	264 357	691 692	-2 311 953
6		946 489	264 357	682 132	-1 629 821
7		937 024	264 357	672 667	- 957 155
8		927 654	264 357	663 297	- 293 858
9		918 377	264 357	654 020	360 162
10		909 193	264 357	644 836	1 004 998
11		900 101	264 357	635 744	1 640 743
12		891 100	264 357	626 743	2 267 486
13		882 189	264 357	617 832	2 885 318
14		873 368	264 357	609 010	3 494 329
15		864 634	264 357	600 277	4 094 605
16		855 988	264 357	591 630	4 686 236
17		847 428	264 357	583 071	5 269 306
18		838 953	264 357	574 596	5 843 903
19		830 564	264 357	566 207	6 410 109
20		822 258	264 357	557 901	6 968 010
21		814 036	264 357	549 679	7 517 689
22		805 895	264 357	541 538	8 059 227
23		797 836	264 357	533 479	8 592 706
24		789 858	264 357	525 501	9 118 207
25		781 959	264 357	517 602	9 635 809
26		774 140	264 357	509 783	10 145 592
27		766 398	264 357	502 041	10 647 633
28		758 734	264 357	494 377	11 142 011
29		751 147	264 357	486 790	11 628 800
30		743 636	264 357	479 278	12 108 079
31		736 199	264 357	471 842	12 579 921
32		728 837	264 357	464 480	13 044 401

**Net Present Value (NPV)**

Equation (8.5) can be written as follows:

$$NPV = \sum_{t=4}^{36} \frac{R_t - (O_t + M_t)}{(1+r)^t} - \sum_{t=0}^3 \frac{I_t}{(1+r)^t}$$

To calculate the above equation it should be taken into account that  $R_t$  varies every year because of change in electricity price. Calculating the equation manually or using the NPV value from an electronic spreadsheet, the NPV obtained is: **€444 803**

**Internal Rate of Return (IRR)**

The IRR is computed using an iterative calculation process, using different discount rates to get the one that makes  $NPV = 0$ , or using the function IRR in an electronic spreadsheet.

NPV using  $r = 8\%$        $NPV = €444\ 803$

NPV using  $r = 9\%$        $NPV = -€40\ 527$

Following the iteration and computing NPV, when the discount rate  $r=8.91\%$  then the NPV is zero and consequently  $IRR = 8.91\%$

**Ratio Benefit/cost**

The NPV at year 35 of the revenues is €8 3 65 208 and the NPV at year 35 of the costs is €7 884 820. This gives:

$$R_{b/c} = 1.061$$

Varying the assumptions can be used to check the sensitivity of the parameters. Table 3 and Table 4 illustrate respectively the NPV and  $R_{b/c}$ , corresponding to the example A, for several life times and several discount rates.

**Table 8.3: NPV against discount rate and lifetime**

Yr./r	6%	8%	10%	12%
25	1 035 189	21 989	- 668 363	-1 137 858
30	1 488 187	281 347	- 518 242	-1 050 050
35	1 801 647	444 803	- 431 924	-1 003 909

**Table 8.4: Rb/c against discount rate and lifetime**

Yr./r	6%	8%	10%	12%
25	1.153	1.020	0.906	0.811
30	1.193	1.050	0.930	0.830
35	1.215	1.061	0.933	0.828

The financial results are very dependent on the price paid for the electricity. Table 5 gives the values NPV,  $R_{b/c}$  and IRR for different tariffs – 35% and 25% lower and 15% and 25% higher than that assumed in example A

**Table 8.5: NPV,  $R_{b/c}$  and IRR for different tariffs (were  $r$  is 8% and the period is 35 years)**

	65%	75%	100%	115%	125%
NPV	-2 266 144	-1 491 587	444 803	1 606 638	2 381 194
B/C	0.690	0.796	1.061	1.220	1.326
IRR	2.67%	4.68%	8.91%	11.16%	12.60%

**Example B**

Shows the annual cash flows if the investment is externally financed with the following assumptions:

- 8% discount rate
- Development time 4 years
- Payments and expenses at the end of the year
- Approximately 70% of the investment financed by the bank with two years grace
- Finance period 12 year
- Bank interest rate 10%
- Project lifetime 30 years

The disbursements are identical as in example A. The bank in the first two years collects only the interest on the unpaid debt, see Table 6.

It must be remarked that the example refers to a hypothetical scheme, although costs and revenues are reasonable in Southern Europe. The objective is to illustrate a practical case to be followed and later applied to another scheme with different costs and revenues.

**Table 8. 6: Example B – Annual cash flows for externally financed investment**

Investment cost - €	O&M costs - €	Discount rate	Lifetime - t	Bank loan	Loan term - yr.	Interest on loan	NPV	R <sub>b/c</sub>	IRR
6 608 928	264 357	8%	35 yr.	4 515 599	12	10%	208 208	1.061	8.72%

Yr	Investment	Bank loan	Investor's investment	Principal repayment	Principal residual	Interest on loan	Revenues	O&M	Investor Cash Flow	Cumulated Cash Flow
-4	- 82 087								- 82 087	- 82 087
-3	- 75 988								- 75 988	- 158 075
-2	-3 074 165	-2 151 916	- 922 249	0	-2 151 916				- 922 249	-1 080 324
-1	-3 376 688	-2 363 683	-1 013 005	0	-4 515 599	- 215 192			-1 013 005	-2 093 329
0				0	-4 515 599	- 451 560	1 005 320	- 264 357	289 403	-1 803 926
1				- 135 023	-4 380 576	- 451 560	995 267	- 264 357	144 327	-1 659 599
2				- 296 835	-4 083 741	- 438 058	985 314	- 264 357	- 13 936	-1 673 535
3				- 326 519	-3 757 222	- 408 374	975 461	- 264 357	- 23 789	-1 697 324
4				- 359 171	-3 398 051	- 375 722	965 706	- 264 357	- 33 544	-1 730 868
5				- 395 088	-3 002 963	- 339 805	956 049	- 264 357	- 43 201	-1 774 069
6				- 434 596	-2 568 367	- 300 296	946 489	- 264 357	- 52 761	-1 826 829
7				- 478 056	-2 090 311	- 256 837	937 024	- 264 357	- 62 226	-1 889 055
8				- 525 862	-1 564 449	- 209 031	927 654	- 264 357	- 71 597	-1 960 652
9				- 578 448	- 986 001	- 156 445	918 377	- 264 357	- 80 873	-2 041 525
10				- 636 293	- 349 708	- 98 600	909 193	- 264 357	- 90 057	-2 131 582
11				- 349 708	0	- 34 971	900 101	- 264 357	251 066	-1 880 516
12							891 100	- 264 357	626 743	-1 253 773
13							882 189	- 264 357	617 832	- 635 940
14							873 368	- 264 357	609 010	- 26 930
15							864 634	- 264 357	600 277	573 347
16							855 988	- 264 357	591 630	1 164 977
17							847 428	- 264 357	583 071	1 748 048
18							838 953	- 264 357	574 596	2 322 644
19							830 564	- 264 357	566 207	2 888 851
20							822 258	- 264 357	557 901	3 446 752
21							814 036	- 264 357	549 679	3 996 430
22							805 895	- 264 357	541 538	4 537 968
23							797 836	- 264 357	533 479	5 071 448
24							789 858	- 264 357	525 501	5 596 948
25							781 959	- 264 357	517 602	6 114 551
26							774 140	- 264 357	509 783	6 624 333
27							766 398	- 264 357	502 041	7 126 375
28							758 734	- 264 357	494 377	7 620 752
29							751 147	- 264 357	486 790	8 107 542
30							743 636	- 264 357	479 278	8 586 820
31							736 199	- 264 357	471 842	9 058 662
32							728 837	- 264 357	464 480	9 523 142

**8.4.3.3 Financial analysis of built schemes in Europe**

In Table 7 several European schemes have been analysed. It must be remarked that both investment costs and buy-back tariffs correspond to reality in the year 1991, and do not necessarily reflect the situation today.

**Table 8.7: Financial analysis of real schemes in Europe**

Country		Germany	France	Ireland	Portugal	Spain
Rated discharge	m <sup>3</sup> /s	0.3	0.6	15	2	104
Gross head	m	47	400	3.5	117	5
Type of Turbine		Francis	Pelton	Kaplan	Francis	Kaplan
Installed capacity	kW	110	1900	430	1630	5000
Investment cost	€	486 500	1297 400	541 400	1148 000	5578 928
Working hours		8 209	4 105	8 400	4 012	3 150
Annual production	MWh	903	7800	3612	6540	15750
Tariff	€/MWh	76.13	53.65	23.23	53.54	63.82
Revenue	€/Yr	68 745	418 443	83 907	350 128	1005 165
O&M	€/Yr	19 850	51 984	25 176	22 960	157 751
O&M	%	4.08	4.01	4.65	2.00	2.83
Gross Profit	€/Yr	48 895	366 459	58 731	327 168	847 414

Economic Analysis						
Capital cost	€/kW	4 423	683	1 259	704	1 116
Capital cost	€/MWh	539	166	150	176	354
Simple payback period	Yr.	9.95	3.54	9.22	3.51	6.58
NPV	€	63 374	2 649 850	115 910	2 375 270	3 739 862
IRR	%	9.37	28.23	10.33	28.49	14.99
B/C		1.15	2.72	1.16	2.82	1.64

The figures have been calculated using a discount rate of 8% over a lifetime of 30 years. You can see that ratios of investment per kW installed, or by annual MWh, produced differ considerably from scheme to scheme. Actual civil works and electromechanical equipment costs varies from country to country. Environmental requirements - affecting investment costs- differ not only from country to country but also from region to region. Buy-back electricity tariffs can be five times higher in one country than in another.

### 8.5 Tariffs and Incentives

A developer’s economic analysis of a scheme would be simplified if electricity tariffs for a MWh were a known and stable entity. However, this is not the case and the markets vary constantly - the present move to liberalise and open up the markets and the promotion of RE’s serves as a good example. Tariffs are agreed in different ways between the generator and supplier and are influenced by national policy. These policies can and do vary from country to country and are reviewed and altered frequently making it difficult to provide more than an overview. Tariffs negotiated through some form of power purchase agreement with the supplier will vary from country to country and will be strongly influenced by that country’s national policy. It is therefore important for the developer to understand clearly implications of the national policy. Similarly, the developer should investigate what supplementary measures are available for the promotion of new RE developments. Chapter 9 (Appendix) provides the different categories of tariff structures and support schemes available in the EU-15. Table 8.8 shows the current prices agreed within the different support schemes in force in the year 2003 in the EU.

**Table 8.8: Prices for SHP generation in the European Union Member States**

Member State	Price for sale to the grid (€cents/kWh)
Belgium	Wallonia: 12.3 = 3.3 (market price) + 9 (green certificate) Flanders: 12.8 = 3.3 (market price) + 9.5 (green certificate)
Denmark	8.48
Germany	7.67 (< 500 kW) 6.65 (500 kW - 5 MW)
	<i>Interconnected system: 6.29 + 113/month</i>
Greece	<i>Non-interconnected islands: 7.78</i>
Spain	6.49 = 3.54 (pool price) + 2.95 (premium)
	Operating before 2001: 7.32 + bonus for regularity of 0.75 (winter) and 2.94 (summer)
France	Commissioned after 2001: <i>SHP &lt; 500 kW: 8.55 + regulatory premium up to 1.52 (winter) and 4.52 (summer)</i> <i>SHP &gt; 500 kW: 7.69 + + regulatory premium up to 1.52 (winter) and 4.07 (summer)</i>
Ireland	6.41 (weighted average price)
Italy	4.6 (spot electricity price) + 10.0 (green certificates)
Luxembourg	3.1 (electricity price) + 2.5 (premium only for plants under 3 MW)
Netherlands	3.3 (market price) + 6.8 (premium)
	<u>Old plants</u>
	1 <sup>st</sup> GWh: 5.68
	1 – 4 GWh: 4.36
	4- 14 GWh: 3.63
	14-24 GWh: 3.28
	+ 24 GWh: 3.15
Austria	<u>New plants</u>

*Rebuilt plants with a production increase per year > 15%*

1<sup>st</sup> GWh: 5.96

1 – 4 GWh: 4.58

4- 14 GWh: 3.81

14-24 GWh: 3.44

+ 24 GWh: 3.31

*New plants or Rebuilt plants with a production increase per year > 50%*

1<sup>st</sup> GWh: 6.25

1 – 4 GWh: 5.01

4- 14 GWh: 4.17

14-24 GWh: 3.94

+ 24 GWh: 3.78

Portugal	7.2
Finland	2.6 (market price) + 0.42 premium if < 1 MW + subsidy covering 30% of the investment cost
Sweden	4.9 = 2.3 (certificate level) + 2.6 (Nordpool price)
United Kingdom	2 (Average price for electricity in the energy market) + 0.38 (exemption to the Climate Change Levy)  4.2 (value of ROC's). When an electrical supply company provide renewable energy to 10% of its costumers it gets the 4.2 but if it fails to provide that percentage it has to pay 4.2 to the government.

<sup>1</sup> By Jamie O’Nians (IT Power), Gema San Bruno (ESHA), Maria Laguna (ESHA) , Celso Penche (ESHA) and the special contribution from Katharina Krell (EUREC Agency)

<sup>2</sup> IDAE. Manual de Minicentrales Hidroeléctricas. Edición Especial CINCO DIAD. 1997

<sup>3</sup> J. Fonkenelle. Comment sélectionner une turbine pour basse chute. Proceedings HIDROENERGIA 91 ,AGENCE FRANCAISE POUR LA MAITRISE DE L'ENERGIE.

<sup>4</sup> DNAEE "APROVEITAMENTOS HIDRELETRICOS DE PEQUENO PORTE" Volumen V "Avaliação de Custos e Benefícios de Pequenas Centrais Hidrelétricas" Modelo FLASH, Brasília 1987

<sup>5</sup> HydrA - PC-based software package for rapidly estimating hydropower potential at any location in the UK or Spain. The software, currently available for Spain and the UK, is being developed for other countries in the European Union. (Institute of Hydrology, Uk, 2000, <http://www.nerc-wallingford.ac.uk/ih/>).

<sup>6</sup> P. Fraenkel et al "Hydrosoft: A software tool for the evaluation of low-head hydropower Resources". HIDROENERGIA97 Conference Proceedings, page 380

<sup>7</sup> Natural Resources, Canada: Canmet, Energy Diversification Research Lab The RETScreen Analysis Software is available as a free download at [www.etscreen.gc.ca](http://www.etscreen.gc.ca), or by mail from CANMET Energy Diversification Research Lab., 1615 Lionel-Boulet PO Box 4800, Varennes PQ, Canada J3X 1S6

<sup>8</sup> Scientific and Technological References Energy Technology Indicators <http://www.cordis.lu/eesd/src/indicators.htm>

<sup>9</sup> Hepburn C, (2002) Long-Run Discounting, Utilities Journal 42, September



## CHAPTER 9: ADMINISTRATIVE PROCEDURES

### CONTENTS

9	Administrative procedures .....	256
9.1	Introduction.....	256
9.2	Types of procedures .....	256
9.2.1	Energy regulation – Water rights.....	257
9.2.2	Environmental procedures .....	259
9.2.3	Public Inquiry.....	262
9.2.4	Construction requirements .....	263
9.2.5	Connection to the grid.....	263
9.2.6	Other procedures .....	263
9.3	Some practical examples.....	264
9.3.1	Greece .....	264
9.3.2	France.....	266
9.3.3	Ireland .....	267
9.3.4	Austria.....	268
9.3.5	Portugal.....	269
9.3.6	Poland .....	271
9.3.7	Switzerland.....	271
APPENDIX A: SMALL HYDROPOWER IN THE INTERNAL ELECTRICITY MARKET .....		273
Bibliography.....		289

### LIST OF FIGURES

Figure 9.1: Regulation of the reserved flow in Switzerland .....	262
Figure 9.2: Portuguese administrative procedures flowchart.....	270
Figure A.1: SHP current trend and White Paper targets .....	275
Figure A.2: RES support policy instruments .....	277

### LIST OF TABLES

Table 9.1: Rights for water use in the EU-15 .....	258
Table A.1: Reference values for Member States’ national indicative targets for the contribution of electricity from renewable energy sources to gross electricity consumption by 2010 .....	274
Table A.2: SHP current support systems used in EU Members States.....	279
Table A.3: Network access in the EU, electricity .....	285
Table A.4: Electricity security of supply .....	286
Table A.5: Environmental policy framework .....	287
Table A.6: Electricity internal market situation in the EU .....	288

## **9 ADMINISTRATIVE PROCEDURES<sup>1</sup>**

### **9.1 Introduction**

One major barrier to the further development of electricity from renewable energy sources are the administrative and planning procedures that potential generators must respect, which is particularly a problem for small and medium-sized companies (SMEs) that make up a significant proportion of companies in this sector.

According to the EU Directive 2001/77/EC (RES-E Directive), Member States of the European Union are required to review their existing legislative and regulatory frameworks concerning authorisation procedures in order to reduce regulatory and non-regulatory obstacles, to rationalise and speed up administrative procedures and to ensure that the rules are transparent and non-discriminatory. These rules have to take account of the particular characteristics of the different technologies using renewable energy sources. The Directive also mentions the obligation of the Member States to report to the European Commission on this review procedure by defining an action to be taken to reduce obstacles in this area. This report has to give an overview of progress made in:

- The co-ordination between the different administrative bodies involved concerning time limits, reception and handling of authorisation requests;
- The establishment of possible guidelines for activities connected with targets, so as to improve administrative procedures and the feasibility of speedy planning for the RES-E producers;
- The appointment of an authority to act as a mediator in disputes between the authorities responsible for issuing authorisations and requesters.

In the Commission's final report on the implementation of the RES- E Directive and on the basis of the Member States' reports, the Commission will evaluate the best practices for reducing regulatory and non-regulatory barriers to increasing RES-E production.

So far administrative procedures vary among Member States, best practices have not yet been defined and part of the procedures, which are now used should be modified in the coming years.

Nevertheless and in order to give to the new SHP developer some information on the administrative process that are needed to implement and to run a SHP plant, this chapter summarises the various types of general procedures and it illustrates some Member States' examples.

### **9.2 Types of procedures<sup>2</sup>**

The implementation of a SHP plant can be looked at from various points of view:

- Energy generation
- Impact on water quality, flora and fauna of the river, and all environmental aspects
- Construction requirements
- Connection to the grid
- Landed properties
- etc...

Regulations have to take into account these various aspects, which are under the responsibility of different authorities. These authorities and responsibilities are different in each Member State depending on the political and administrative organization and on its involvement in the development of renewable energy sources.

In this context, the procedures vary from one country to another, but also within a country from one region to the other and even often, in the same region, from one project to the other. These procedures - that are far from being transparent, objective and non discriminatory- are supervised by several local administrations, very sensitive to pressure groups, which multiply the number of interlocutors, and extend the time to take decisions (up to 58 permits from different administrations are necessary in some Italian locations). In all countries the project has to be made public and people can react.

### 9.2.1 Energy regulation – Water rights

The water of a river is used for different purposes: irrigation, fishing, industrial use, leisure, etc...Regulations are necessary in order to allow the best possible access to these various uses. In almost all Member States water has public domain status (in Ireland and in some Nordic countries, water rights are regulated according to the riparian rights system).

Regulation of the use of the energetic aspects has been developed during the 20<sup>th</sup> century with the development of electricity. For example, Article 1 of the French law of 16 October 1919 specifies “no one can use the energy of tides, lakes and water courses without a concession or an authorization from the State”. It specifies that “small” plants (< 4 500 kW, since 1980) can be run by private producers with an authorization, and that bigger plants are to be run under a concession procedure.

The procedure is lengthy, because the river authority, generally responsible for it, should exchange information with the regional administration that is responsible for the environmental aspects. In some countries it can take more than five years to agree it. Once the plant is built, the competent authorities should verify on the site that the works conform to the requirements of the water use licence and then the minutes of the visit may constitute the permission to operate the plant.

Table 9.1 shows the authority granting rights for water use and the validity time of the authorization in the European Union, according to information collected in 1997<sup>3</sup>.

**Table 9.1: Rights for water use in the EU-15**

Country	Authority granting rights for water use	Validity time of the authorization
Belgium	< 1MW the provinces	Undetermined
	> 1MW same + Ministry of Energy	33 a 99 years
Denmark	Ministry of Energy	Undetermined
Germany	Länders	30 years
Greece	Ministry of Energy	10 years, renewable
Spain	Basin authority except in some rivers in Catalunya and Galicia	25 years + 15 of grace
France	< 4,5 MW Department Prefecture	In practice up to 40 years
	> 4,5 MW State	
Ireland	Not needed. Riparian rights in force	Perpetual
Italy	< 3MW regional authorities	30 year
	> 3MW Ministry of Industry	
Luxemburg	Ministries of Agriculture, Public Works, Environm. & Employment + local authorities	Undetermined
Netherlands	National & Local Water Boards	At minimum 20 years
Austria	< 200 kW local governments	Usual 30 years
	> 200 kW country governments	Possible more (60-90 years)
Portugal	DRARN (Regional Authority for Environment & Natural Resources)	35 years renewable
Sweden	Water Court	Perpetual (30 years)
U. K	Environmental Agency	England & Wales 15 years
	In Scotland not required if P<1MW;	Scotland undetermined
	If P>1 MW Secretary of State	

### 9.2.2 Environmental procedures

Since the 1970's environmental integration has become a relevant element of SHP projects and therefore most of the legislation in force in the European Member States includes the protection of the Environment.

At European level, there are currently two pieces of legislation with an impact in SHP projects:

- Natura 2000
- Directive 2000/60/CE (Water Framework Directive).

#### 9.2.2.1 Environmental Impact Assessment

In most of the Member States, an environmental impact assessment (EIA) must be carried out in order to get the licence for water use.

This study is a scientific and technical analysis, which makes an inventory of the present situation and foresees the consequences on the environment to be expected from the implementation of the project. It concerns the fauna and the flora, the sites and landscapes, the ground, the water, the air, the climate, the natural surroundings and the biological equilibriums, the protection of goods and of the cultural patrimony, the comfort of the neighbourhood (noise, vibrations, smells, lightning), hygiene, security, public salubrity and health.

It is a synthesis of various environmental expertises implemented on the site: hydro-biological expertises, choice of the reserved flow, landscape analysis, etc...

An EIA has three main purposes:

- *Protection of the environment.* It does not only cover the conservation of spaces and species and the classification of territories in order to take them away from the human activities, but also it integrates the environment in planning actions. Therefore, it means to conceive projects (i) respecting man, landscape and natural mediums, (ii) which spare space and natural resources and (iii) limit water, air and ground pollution.
- *Information for the public authorities and the public.* As a tool for the information of the public authorities, the EIA is an official piece of the administrative decision file. It is also a tool for the information of the public, in particular in the public inquiries.
- *Help for decision.* As a scientific and technical analysis of the environmental constraints, the EIA constitutes one of the preliminary studies the developer has to implement. Together with the technical and economic studies, it contributes in improving the project.

#### 9.2.2.1 Reserved flow

The flow of water giving a satisfactory generation of electricity while preserving the aquatic habitat, various environmental parameters whilst maintaining the various uses of the river, has been traditionally the main object of discussion between investors on the one hand and fishermen, environmental agencies and associations for the preservation of the environment on the other hand. Whereas for the developer producing electricity without damaging the global atmosphere merits every kind of support without heavy curtailments in the generation capacity for the environmental

agencies and various associations concerned by the preservation of the environment, a low reserved flow is equivalent to an attack on the public good: the aquatic fauna.

The rules have generally been established at national level and only fixed at a minimum value. This has allowed local authorities to set at least the minimum and in many cases impose reserved flow values at an unreasonably high value. Following the approval by the Council of the Water Directive (Directive 2000/60/EC of 23 October 2000) water authorities are becoming more involved in this definition. Whereas in the past the national laws determined the reserved flow as a certain percentile of the module (inter annual average flow), the water authorities study the different stream reaches including hydrological and wildlife data collection, water quality and aquatics 1D/2D models. The values found for the reserved flow are usually higher but are at least scientifically determined.

The developer has to present in his EIA the value he proposes and the way it is calculated.

But, as detailed in chapter 7, the formulas are many and their number tends to increase day by day. This is a real problem for the legislator who has to set up the regulation, and in concrete cases it makes it difficult to have reference values or formulas to comply with. The main types of methods are detailed in chapter 7<sup>4</sup>:

- Methods based on hydrologic or statistic values
- Formulas based on velocity and depth of water
- Methods based on multi-objective planning taking into consideration ecological parameters.

Inside a given group of methods, the differences in the results can be very significant from one method to another.

No global comparison is possible between different groups of methods, as they do not refer to the same data. It is only possible to compare the results of different types of methods in real cases on which one knows all the necessary data. The application of 24 different methods to a wide low slope river gave 24 different results and the ratio between maximum and minimum value of the reserved flow was 192! Even when the four highest and the four lowest results are not considered then the ratio was still 14 between the highest and lowest results.

A consequence of all these different methods is that the national regulations can also be very different.

In the following paragraphs a very brief survey will be made in order to give an idea about the different methods applied.

#### *Germany*

There is no regulation valid for the whole country. The *Länder* have their specific regulation. A very common approach depends on the “mean minimum flow” (MNQ). Usually 1/3 to 1/6 is the amount of residual flow. More often the 1/3 option is chosen. The governmental representatives take the final decision during the granting procedure.

#### *Greece*

Reserved flow must be at least 1/3 of the average summer flow rate of the river.

### *Spain*

In the 1985 Spanish Water Act the residual flow was established at 10% of the inter-annual average flow. This was considered by the different autonomic and local institutions as a minimum value, and in every new project a higher and often arbitrary value has been fixed. In the new Water Act of July 2001 the reserved flow must be established in the "River basin management plans" to be made by the corresponding river authorities (in Spain there are 14). In fact, up to now, only one river authority (the Basque) has elaborated a computer programme to fix it.

### *France*

The minimal flow should not be lower than 1/10 of the module of the river corresponding to the inter-annual medium flow, evaluated from information available relating to a five years minimum period, or the flow with the immediately upstream of the work, if this one is lower. However, for the rivers or parts of rivers whose module is higher than 80 m<sup>3</sup>/s, a decree of Council of State can, for each one of them, fix a lower flow, which should not be below 1/20 of the module.

### *Italy*

The reserved flow rules are fixed by River Basin Authorities or by Regional Governments and there are many regulations to conform to. Anyway the general tendency is for hypsographic methods with correction factors. The regulation is currently under review.

### *Austria*

Austria has no general formula to be applied but some approaches to obtain a "correct" value. Usually the decision is taken by an official expert, including the granting procedure and this can lead to variability as the expertise of different people leads to different results. A first approximation is usually done with hydrological parameters, using the range between "annual mean minimum flow" (MNQ) and "annual minimum flow" (NNQ). A useful but sometimes expensive tool to avoid a rather high fixation is the presentation of a specific expertise based on dotation testing. Governmental experts will in most cases accept the result.

### *Portugal*

Reserved flow must be equal or higher than 1/10 of the average inter-annual flow rate.

### *United Kingdom*

The UK has no standard method. The main river authority (Environment Agency) looks at each site on an individual basis before granting a license. The starting point for negotiations is usually Q95 (that is the discharge which flows for more than 95% of the year), but it can be more or less than this in reality.

In Scotland, reserved flow must be equal or higher than 45% of the average inter-annual flow rate.

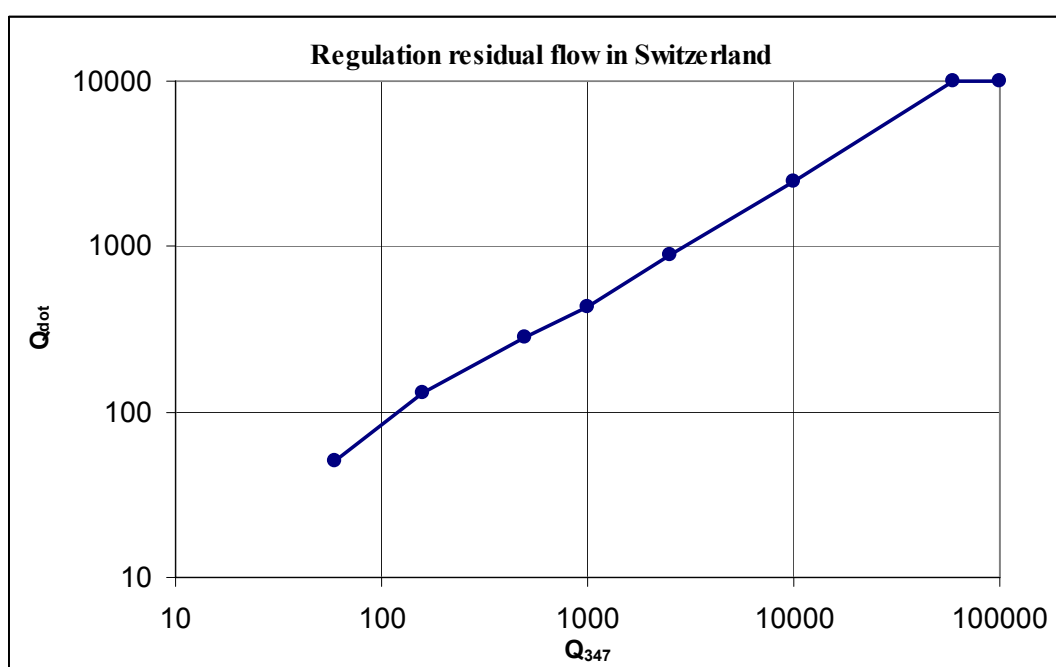
### *Lithuania*

The Lithuanian territory is split up into two different hydrological regions in which different reserved flow values are imposed. For the first hydrological region, where the rivers have irregular

flow pattern; reserved flow is equivalent to the low flow warm season (from April to October) of 30 days duration value corresponding to the 5-years return period (probability - 0.80). The second hydrological region, which characterized by more regular river flow pattern, the reserved flow value is less and it is calculated using above methodology, but low flow return period is fixed at 20-years (probability - 0.95). In the diversion schemes, independently of the type of hydrological region, the minimum reserved flow in channel for diverted water is fixed at 10% of the long-term average seasonal flow.

*Switzerland*

Although Switzerland is not part of the EU their regulations concerning reserved flow are worth mentioning. The fixation is based upon the  $Q_{347}$ , (discharge appearing more than 95% of the year), obviously a kind of low flow. The graph shows the dependencies:



**Figure 9.1: Regulation of the reserved flow in Switzerland**

At very little discharge the reserved flow starts with 80% of  $Q_{347}$ , at 10 000l/s the percentage has been reduced to 25%, and from 60 000 l/s it stays at 10 000 l/s.

9.2.3 Public Inquiry

In some Member States, the developer has to submit the project to a public inquiry, this procedure being generally simplified for small capacity plants. This inquiry is demanded by the authority in charge of the decision of approving the implementation of the plant. The objective of this inquiry is to inform the public and to collect its opinions, suggestions and counter-proposals so that the public has been included and the authority has at its disposal all the necessary information.

An auditor leads the inquiry: site visit, demand for complementary information, management of a public meeting, and extension of the inquiry time. Its mission is concluded by a report to the competent authority taking into account the observations of the public. The auditor must write consistent and clear conclusions and specify whether he agrees with the project or not, or if he



would agree with reserves or conditions. The authority can take the conclusions of the auditor report into account or not.

#### 9.2.4 Construction requirements

A building licence is generally necessary too. It is delivered separately from the water right. It is the responsibility of the town-planning authorities and its procedure is defined within the town-planning rules of the country or of the region. It often includes a landscape study of the site and of the integration of the project in the environment. The administrative service in charge of the project has to check its conformity with the town-planning documents.

#### 9.2.5 Connection to the grid

The connection to the grid is a procedure different from the water right. It must be asked to the authority in charge of the concerned grid (high or low voltage depending on the power delivered).

Because of the European effort for the development of renewable energy sources, utilities have received a large increase in demand for the connection of decentralised plants, in particular of wind farms. The connection capacity of the local grid may be saturated. In which case, in order to accept more connections it is necessary to reinforce the grid, which of course is much more expensive than a simple connection. And on the other hand, it is necessary to be sure, of which connections have to be planned, in order to avoid the reinforcement of the grid if it is not necessary.

To address this situation, France has introduced a system of queue. For each demand, a pre-study of the project is first done, at the end of this study, the utility gives an answer to the developer who then can ask for a detailed study of the connection of the plant. The price of this procedure can include the reinforcement costs, but a part of these costs will be reimbursed later if other producers use the equipments paid by the first developer.

#### 9.2.6 Other procedures

Some other procedures include:

- *Land reclaiming authorisation.* A land planted with trees may have to be used as a way to access the plant, implant a water way, a penstock, etc... In these cases an authorisation may be necessary to reclaim the land, depending on the juridical status of the forest. The authority to be contacted is the one in charge of agriculture and forests.
- *Agreements of borders and land property:* A SHP developer is not always the owner of all the land necessary for the project. He may need to build a penstock, an access way or a part of a waterway on the land of a neighbour.

The developer will have to find an agreement with the neighbours concerned by the project. Where the Municipality is the developer they often have additional rights and powers above the private developer that they are at liberty to exercise. If no agreement is reached, the Municipality can insist that the landowner agrees in the public interest, something that private developer is not capable of enforcing.

### 9.3 Some practical examples<sup>5</sup>

#### 9.3.1 Greece

According to the current Greek legal framework, three main licences are necessary for the building and operation of a RES-electricity plant:

- Electricity Generation Licence
- Installation Licence
- Operation Licence

The first of these is obtained at national level and it provides an initial approval that a certain project is possible. Generally, it is rather straightforward to obtain this licence if there are no "grey" points in the application. The Installation Licence is the most difficult of the three to obtain. The procedure is very complicated and involves a large number of entities. Recently (April 2003) a new Ministerial Decision (1726/2003) has been issued to simplify and accelerate the procedure for this licence.

The Operation Licence is issued after the completion of all construction works, and in a way certifies that the plant has been built according to the two other licences and the relevant studies submitted, and according to the existing legal framework in general.

##### 9.3.1.1 **Electricity Generation Licence**

The acquisition of the "Electricity Generation Licence" is the first step on the road of acquiring all the necessary licences for building and operating a RES-electricity installation. This licence is issued by the Ministry of Development, following an opinion by the Energy Regulatory Authority. The application for this licence is accompanied by the following:

- General information about the entity seeking the license: legal name, address, names of directors of board (where applicable), organisation chart, etc.
- Recent financial statements, including the balance sheets and the income statements of the three most recent years
- Business plan, covering at least a period of five years
- Feasibility study.

##### 9.3.2.2. **Installation licence**

- The procedure for acquiring this licence is the most complicated and time-consuming. For the issuing of the installation license for a RES-electricity project, the applicant should file an application with the Regional Authority. The format of this application is given by the Ministerial Decision 2000/2002. The holding of a valid Electricity Generation Licence is a requirement for filing the application. The application is accompanied by a number of supporting documents, studies, maps etc.

Although the Regional Authority is the "single point" for filing the application for the installation licence, this does not mean that the application is only processed internally in the Region's departments. On the contrary, the Regional Authority asks the opinion of numerous Services before

issuing the installation licence. Also, a number of other "intermediate" licences are required before the final decision.

The installation licence for small hydro projects has a validity period of two years. This means that the applicant has to complete the works within this period. An extension of one more year can be granted, provided that at least 70% of the works will have been completed.

#### Application Package

The application for the Installation Licence is filed together with the following:

- Certificate of exclusive use of the site.
- Technical Description
- Environmental Impact Study
- Maps and photos
- Solemn declarations
- Supporting Technical Description for the interconnection to the transmission system.
- Other supporting documents.

#### Advisory Authorities and Bodies for the Environmental Impact Appraisal

- In the process of issuing the Installation Licence, the Regional Authority also issues an "Approval of Environmental Terms and Conditions" which is a necessary prerequisite for the Installation License. For this Approval, which is based on the Environmental Impact Study submitted by the applicant, the Regional Authority asks for advisory opinions from a number of other Authorities and Bodies: Chief Forester's Office, City Planning Service, curators of Prehistoric and Classical Antiquities, Curators of Byzantine Antiquities and Curators of Modern Monuments, Civil Aviation Authority, Ministry of National Defence General Staff, Greek Telecommunications Organization, Greek National Tourism Organization.

#### Publicity procedure for the Environmental Impact Appraisal

- Before issuing the "Approval of Environmental Terms and Conditions" the Regional Authority has to publicize the application of the prospective RES investor. To this end, a copy of the application package is sent to the competent prefecture and municipal authorities. The authorities of the three levels (regional, prefectural and municipal) put a relevant notification on their bulletin boards and ask for any objection within a period of 30 days.

In case of objections, the proposed project is discussed in an open meeting of the prefectural or municipal council. The council submits its final comments and suggestions to the Regional Authority that finally decides on the environmental authorisation of the given project.

### 9.3.1.2 Operation Licence

This licence is granted by the Regional Authority, following completion of the construction works and after checking and certification by relevant Services of the project's compliance with all the terms and conditions concerning its installation and operation.

The application for the operation licence is submitted together with supporting documents.

### 9.3.2 France<sup>6</sup>

The French regulation distinguishes the projects less than 4 500 kW from those more than 4 500 kW. The first ones need an authorisation delivered by the *préfet*, the local representative of the government. The necessary procedure is described below. Where there are difficulties, this process may take up to five or ten years. Besides the 2001/77/EC Directive, the French government organised a debate on the simplification of procedures in RES projects. The main conclusion for SHP was that the procedure should not last more than 2 years.

Projects bigger than 4 500 kW need a concession which is granted by the Council of state. It has a maximum duration of 75 years and can be renewed in thirty years periods. Whereas the authorization may be precarious and eventually be repealed without indemnity in case of national defence, public safety, etc..., the concession gives the advantages of a public utility status, but its procedure is heavier. These projects need a high level of specialization and the concession procedure is not presented in this guidebook.

#### 9.3.2.1 “Classified rivers”

An important point of the French regulation is that a part of the river network, classified by decrees in reference to the 16 October 1919 law, is forbidden to the energetic use. So, the developer has firstly to check if the site is not “classified”.

#### 9.3.2.2 Authorisation procedure

According to the 16/10/1919 law, like the concession, the authorization is granted for a maximum of 75 years and can be renewed. In fact, this duration is now generally shortened to 30 years, so that at each renewal, the producer can comply with the new regulation.

The 95-1204 decree of 6/11/1995 specifies the documents and information to be supplied in the application file. They mainly include:

- Information on the developer
- A technical and geographical file of the project
- An **environmental impact assessment** for projects of raw maximum power more than 500 kW; if this power is less than 500 kW, a simpler study (“notice d’impact”) is enough
- Duration asked for the authorization
- Economic and financial information
- Land properties

The application file is to be sent to the *préfet* who forwards it to the service in charge of the police of water (SPE, “service chargé de la police des Eaux”). The SPE studies the file and transmits it to the regional public authorities: Direction régionale de l’industrie, de la recherche et de l’environnement (DRIRE), Direction régionale de l’environnement (DIREN), Conseil supérieur de la pêche (CSP). It can ask the developer for more information. After reception of the various opinions, the SPE forwards the file to the *préfet*. If the *préfet* agrees with the project, he passes a decree deciding a public inquiry.

After receiving the advice of the County Council, the Mayors and of all the concerned services, a water right is written and proposed by the SPE. The *préfet* takes his final decision. If he agrees, he signs an authorization *decree* and the works are executed. At the end of the works, the equipment is checked and the agreement of the public authority is given in a report of checking.

### 9.3.2.3 Connection to the grid

According to the law of the 10 February 2000 and its decrees, the grid has the obligation to buy the electricity generated by RES plants of capacity less than 12 MW, but the producer has to demonstrate that he cannot sell its production at a good price to another client and he must forward an application to the utility. For capacities less than 10 MW, the connection is done to the distribution grid (low voltage). For capacities upper than 10 MW, the plant is connected to the high voltage electricity transfer grid.

In parallel, the developer has two procedures to follow:

- An application of authorization to run the plant is to be sent to the ministry in charge of energy (2000-877 decree of 7 September 2000).
- A certificate of purchasing obligation is to be asked to the regional Direction of Industry.

### 9.3.3 Ireland

In Ireland, the procedures are as follows:

#### 9.3.3.1 Planning Permission

The planning application consists of an application form and of several documents maps and plans. The planner must take all references to renewable energy in the Development Plan into account. Development Plans must be reviewed every 5 years.

The developer has to provide information on how the development will impact on the area. This is done via an Environmental Impact Statement (EIS). An EIS will also be required if the development is located in a National Heritage Area (NHA), Special Area of Conservation (SAC), Special Protection Area (SPA) or other designated areas.

An Environmental Impact Statement is legally defined in the Local Government (Planning and Development) Regulations, 1990. A typical EIS would contain examinations of the impact of the project on the following: Water, soils & geology, air quality, noise, flora & fauna, cultural heritage, electromagnetic fields, visual impact, climatic effects, interaction of impacts, alternatives. An EIS will decide whether the application is successful or not. It needs to be clear, thorough and cover all areas of interest to the planner. Planners, and officers from the statutory bodies, are available to provide advice on scooping an EIS.

### 9.3.3.2 Electricity Regulation Agreements

There are two agreements to be arranged:

1. Licence to Construct. Anyone wishing to construct a new generating station or reconstruct an existing generating station must obtain an Authorisation to Construct under Section 16 of the Electricity Regulation Act, 1999.
2. Generators Licence. Under Section 14 (1) (a) the Electricity Regulation Act, 1999, the Commission has powers to grant, or refuse to grant, a Licence to Generate Electricity.

There is a streamlined application process, for both licences, for developments under 5MW. The commission must be satisfied that the development meets the criteria below in order to grant a licence. However, discussions are underway regarding exemptions from these licences for smaller developments:

- Will not impact adversely on grid capacity or stability
- Is financially viable
- Observes environmental standards

### 9.3.3.3 Power Purchase Agreements (PPA)

In order to arrange finance from a bank, the developer will have to demonstrate a guaranteed purchaser for his electricity for a number of years. There are currently two main ways of doing this:

1. Alternative Energy Requirement (AER) programme. This is a competition organised by the government, who awards contracts to individual generators. These contracts require the Public Electricity Supplier to purchase the electricity at a set price for 15 years. There is significant competition for these contracts and there is no guarantee of being granted one.
2. Third Party Access: It is possible to come to an arrangement with a supplier in the electricity market, who would give the developer a contract guaranteeing that they will purchase the electricity at a given price for a given period. These can also be quite competitive and will not be significantly higher than the AER prices.

### 9.3.4 Austria

The first administrative step should be discussion with the responsible experts at the governmental body. The developer has to write what amounts to a pre-feasibility with the main decisions (river, location, head, discharge, system, power, production etc.) and to present it to the government. This is a pre-check to avoid collision with possible other projects or general position of the government.

After passing that step usually a so-called "wasserrechtliches Einreichprojekt" (a project prepared to get the right to building the site) is prepared. Compared with the pre-feasibility it gives all the necessary details. That project is the basis for the negotiations within the granting procedure. A main part of this procedure is the public discussions. Within this step people involved (including fishermen etc.) can say what they want or what they do not want. The chairman of this meeting has to collect all the opinions and finally find a decision whether the project can be built or not.

The next step is related to the environmental law. Although ecological items are included in the "water right" there might be additional demands and a separate procedure. The license will be valid for at least 30 years but longer periods can also be asked for. There is no "water fee" (Wasserzins) to be paid.

A good preparation of the project and co-operating with those responsible for the governmental evaluation is of highest importance. This preparation has to include several talks, serious ecological management (proposed by an additional expert, being part of the team). Up to now there are no "forbidden rivers" although in some cases everybody knows, that a project would never get a license – there are implicit forbidden rivers.

There is no general rule about residual flow. Usually the value varies between NNQ (lowest low flow) and MNQ (mean low flow). In many cases it makes sense to make a short individual study. Without this the governmental experts are able to provide their position without specific information, the result of which is often cautiously high - very much higher than the result of the study, so it can be worth the expense.

### 9.3.5 Portugal

The Portuguese administrative procedure flowchart below is given by way of example. The main steps of the administrative process to fulfil exploitation of a SHP scheme and to achieve independent production of electricity (production in special regime) are represented in this flowchart - it considers the grant of the four fundamental licences:

- Licence of Construction of Hydraulic Works.
- Licence of Establishment.
- Licence of Water Use.
- Licence of Exploitation.

Due to informational purposes, the necessary taxes and guarantees for the development of the process are included, except the ones related to the General Directorate for Energy, which represent much lower financial costs.

In the chart does not address the question of SHP development in an environmental sensitive area (e.g. Natura 2000 Network), it is considered that the costs of the EIA process (Environmental Impact Assessment) are not compatible with the relatively small budgets of SHP with a lower capacity than 1 MW. In the flowchart of the process development the request for the Reception Point made to General Directorate for Energy was inserted as a consequence of the granting of the Dispatch of the Regional Direction for the Ministry of Environment - though this specific situation is not addressed by the legislation.

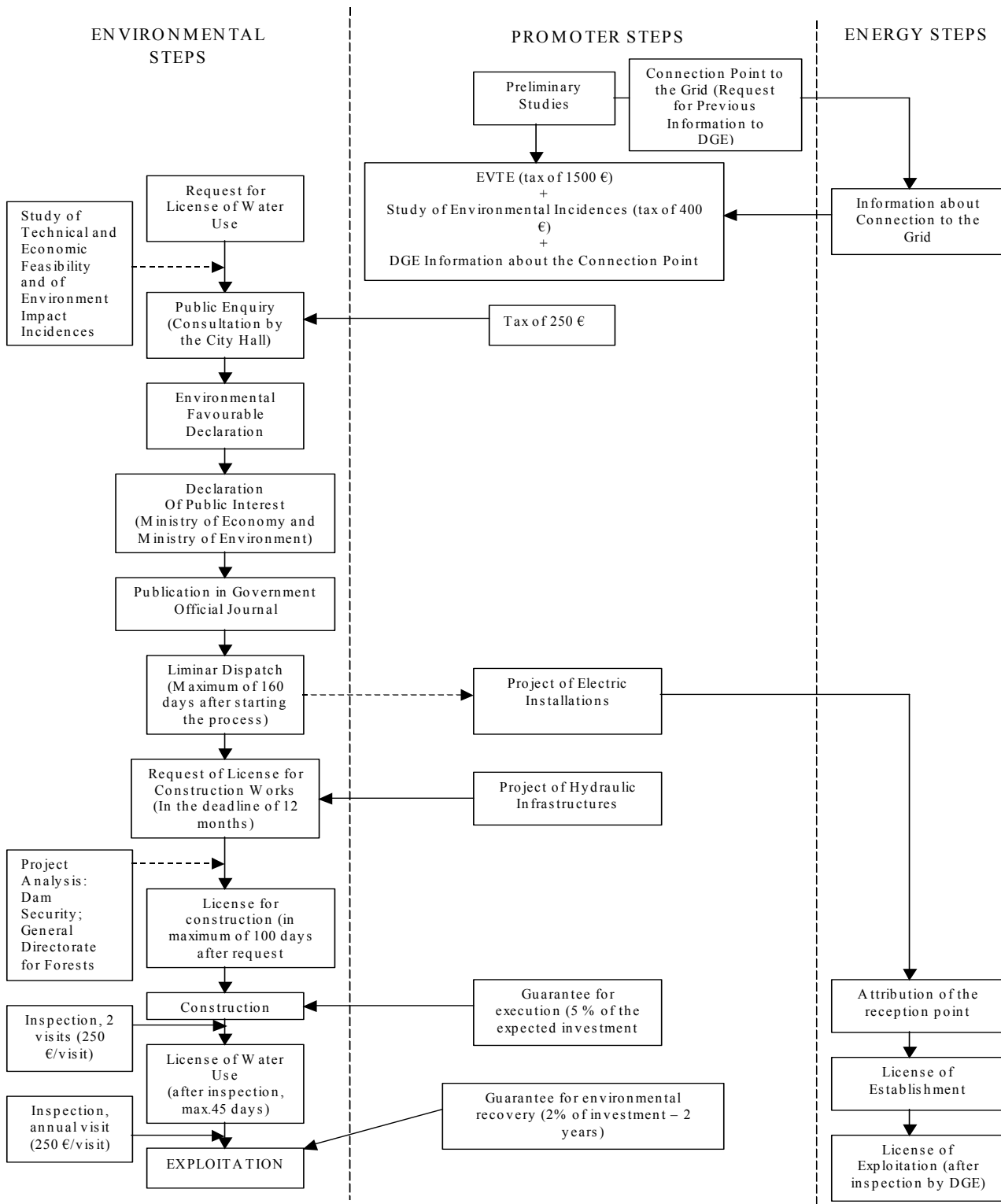


Figure 9.2: Portuguese administrative procedures flowchart



### 9.3.6 Poland

The procedure includes four main stages:

#### Stage 1

Application to the Water Authority (*Regionalny Zarząd Gospodarki Wodnej, RZGW*) An initial approach is made to the Water Authority in which a site is proposed as a possible location. The Water Authority considers this and then gives a decision. If **general approval** is given, this will outline the general conditions that are needed.

#### Stage 2

Application to the Gmina in which the proposal is situated. A more detailed proposal is made to the local *Gmina* (the municipality). This is an application for the *WZIZT (Warunki Zabudowy I zagospodarowania terenu* – Conditions for Construction and management of land). This proposal gives basic data about the investment (size, where exactly located, what changes this will make to the land etc.). The Gmina considers this in relation to its planning documents and policies (in particular its local plan) and then issues a decision including the relevant conditions

#### Stage 3

An application is made to the *Powiat* (District Authority). This will award the *Operat wodno-prawny* (Water and Legal Operating permission). This is the key document and to obtain this all the data about the investment need to be produced. The document is very detailed and also contains the approval of the water authority which can change its opinion at this stage should it so decide. Information to be provided includes a business plan, and environmental assessment and detailed maintenance arrangements and so on. Following this the *Powiat* gives the developer a *Pozwolenie na budowę* (Building permit) in it says who will have to approve the construction after completion. They have complete freedom in this – it can be anyone even the local chimney sweep. Following this a new application has to be made to the Water Authority, *Gmina* and *Powiat* to get permission to start operating.

#### Stage 4

Connection to the networks. Negotiation of conditions of access to the network and contracts for sale are carried out separately and can be very difficult. Normally a prediction of daily production expected and hourly production schedules are required and fines are levied if the producer does not keep to his predictions.

### 9.3.7 Switzerland

As any federal State, Switzerland has rules, which vary from one canton to another. Nevertheless the procedures are similar and a certain number of federal laws apply:

- Law on the protection of water: [http://www.admin.ch/ch/f/rs/c814\\_20.html](http://www.admin.ch/ch/f/rs/c814_20.html) (residual flows)
- Law on energy: [http://www.admin.ch/ch/f/rs/c730\\_0.html](http://www.admin.ch/ch/f/rs/c730_0.html) (access to the network and buy-back conditions)
- Law on the hydraulic forces: [http://www.admin.ch/ch/f/rs/c721\\_80.html](http://www.admin.ch/ch/f/rs/c721_80.html) (regulation of the concessions)

They are the principal laws fixing the legislative framework in Switzerland for the hydroelectric power stations, the small ones in particular.

In addition, the new law on the nuclear energy which will come into effect amends the law on energy as it introduces a compensation fund taken from the high voltage transmission to finance the preferential rates granted to the energy producers from SHP.

The granting of the concession can be of cantonal (canton of Vaud for example), communal (it is the case in Valais) or bourgeoisiale (in some cantons) competence. There is no request for concession, which goes up at the federal level. On the other hand, there is an authority for the supervision of great installations.

The plants using drinking water and wastewater do not need concessions. In general, a simple authorization of the canton is enough. It is not systematic.

The normal procedure is given in the chapter 7 of the document “Introduction to the construction and the exploitation of SHP”. This document is downloadable on: [http://www.smallhydro.ch/français/download/download\\_f.htm](http://www.smallhydro.ch/français/download/download_f.htm)

For more information, contact the federal energy office (<http://www.suisse-energie.ch/internet/02007/index.html?lang=fr>)

**Appendix A** gives a general overview of the current legislative framework that the small hydropower sector has to comply with at European level.

## **APPENDIX A: SMALL HYDROPOWER IN THE INTERNAL ELECTRICITY MARKET**

### **INTRODUCTION**

The European electricity sector is moving away from a monopoly on generation toward a competitive market in which customers will have the opportunity to choose among power suppliers. That is already happening in some Member States (MS) of the European Union (EU) like Austria, Denmark, Finland, Germany, Spain, Sweden and the UK (where the declared market opening is of 100%)<sup>7</sup> and shortly it will happen in all of them. We are moving away from complex regulatory schemes toward greater reliance upon market mechanisms. One essential element of the new market rules is to ensure that those rules drive the restructured market toward cleaner resources that are compatible with the public interest. Climate scientists overwhelmingly agree that greenhouse gases are responsible for the Climate Change and that serious damage to the earth's environment will result, with enormous consequences for humanity. Furthermore the EU has to comply with the Kyoto Protocol and improve the security of energy resources supply, using indigenous renewable resources to reduce our dependence upon imported fuels.

In this new context, the market position of the European small hydropower sector depends on the legislative framework in force in the EU. There are mainly two relevant legislative pieces:

- Directive 2001/77/EC for the promotion of electricity from renewable energy sources (RES), known as the RES-E Directive. It sets the legal framework applicable in all MS for the promotion of electricity generated from RES establishing an ambitious target of doubling the contribution of RES to the gross inland consumption by 2010 in the EU.
- Directive 2003/53/EC concerning common rules for the internal market in electricity which establishes common rules for the generation, transmission, distribution and supply of electricity. It lays down the rules relating to the organisation and functioning of the electricity sector, access to the market and the operation of the systems among others.

Within this legislative framework, there are three aspects which concern the small hydropower sector in particular: (i) targets settled in the legislation and the difficulty to achieve them, (ii) tariff structures and support schemes currently in force and their effectiveness and (iii) barriers still standing despite the new favourable legislative framework.

### **A.1 TARGETS**

The RES-E Directive establishes national indicative targets for the contribution of electricity from RES to gross electricity consumption by 2010 in each MS. However, it does not give any indication for the contribution of each RES to the total objective, letting this decision to each MS. Although this is totally according to the definition of a Directive and the subsidiarity principle, it could create unhealthy competition between the different RES. Table A.1 shows the indicative national targets for each MS settled in the Directive.

**Table A.1: Reference values for Member States' national indicative targets for the contribution of electricity from renewable energy sources to gross electricity consumption by 2010**

	RES-E TWh 1997	RES-E TWh 1997	RES-E % 2010
<b>Belgium</b>	0.86	1.1	6.0
<b>Denmark</b>	3.21	8.7	29.0
<b>Germany</b>	24.91	4.5	12.5
<b>Greece</b>	3.94	8.6	20.1
<b>Spain</b>	37.15	19.9	29.4
<b>France</b>	66.00	15.0	21.0
<b>Ireland</b>	0.84	3.6	13.2
<b>Italy</b>	46.46	16.0	25.0
<b>Luxembourg</b>	0.14	2.1	5.7
<b>Netherlands</b>	3.45	3.5	9.0
<b>Austria</b>	39.05	70.0	78.1
<b>Portugal</b>	14.30	38.5	39.0
<b>Finland</b>	19.03	24.7	31.5
<b>Sweden</b>	72.03	49.1	60.0
<b>United Kingdom</b>	7.04	1.7	10.0
<b>European Community</b>	<b>338.41</b>	<b>13.9</b>	<b>22</b>

In October 2003, MS will start to report to the European Commission about their national strategy on how to reach the foreseen target according to the different RES. Once the national legislation establishes concrete objectives for the short-medium term by type of technology, an assessment of RES-E directive effectiveness for the small hydropower (SHP) sector can be carried out.

Nevertheless, The White Paper for a Community Strategy and Action Plan COM (97) 599 final (26/11/97) set up a concrete and ambitious target for small hydropower of about 14 000 MW of install capacity by the year 2010. As shown in figure A.1, applying the average annual growth rate of the last years up to the year 2010, the European small hydraulic capacity would remain in the neighbourhood of 12 000 MW but is generally agreed that the target still could be achieved if the regulatory framework were streamlined.

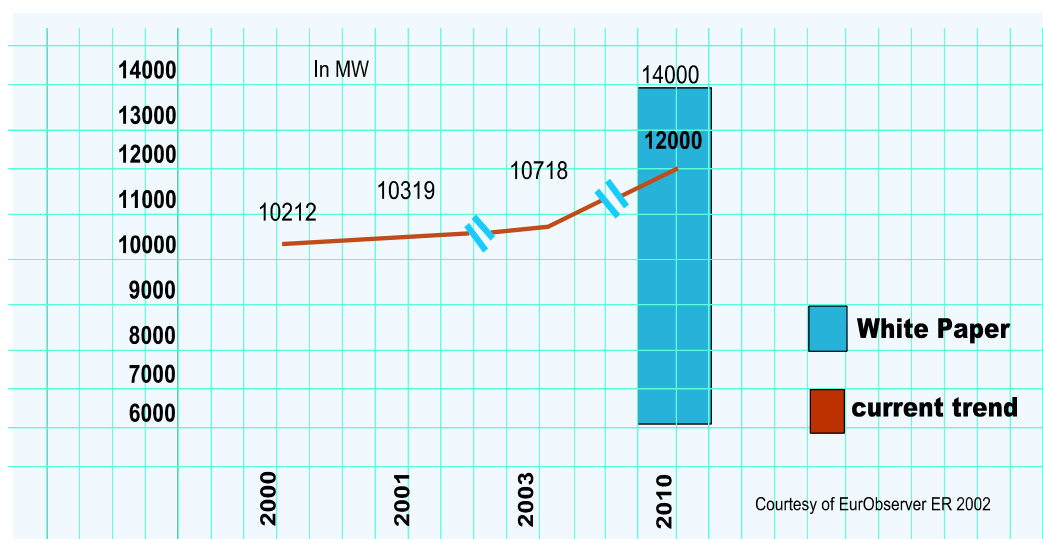


Figure A.1: SHP current trend and White Paper targets

According to the national SHP associations, the slowness of small hydropower development in recent years is not, in most cases, due to economic reasons but to the existence of significant administrative and environmental obstacles. Although the definition of an adequate small hydropower economic support framework is a condition, sine qua non, it is not enough to promote the development thereof. If the Commission wish to design a complete small hydropower support policy it will have to include among its priorities the removal of the administrative and environmental barriers that are blocking development and have, at least, the same importance as that with which is given to the creation of a common compensatory framework.

## A.2 TARIFF STRUCTURES & SUPPORT SCHEMES

The promotion of renewables, aimed at increasing their share in the fuel mix, notably by ensuring efficient and appropriate support schemes is at the core of the EU energy policy objectives: security and diversity of supply, competitiveness and environmental protection. Besides, RES will need support in the short and medium term to develop and fulfil Kyoto commitments. The reasons for the need of support are basically linked to two elements:

- **Cost.** The biggest disadvantage of RES at the moment is that under the current framework conditions, characterised by the non-internalisation of external costs of energy production, costs tend to be significantly higher than those of conventional sources of energy. It is generally acknowledged that conventional energy sources not only do not pay their full external costs, but also on top of that are strongly subsidised. Research conducted for the EU in the ExternE project shows that the cost of electricity generated from coal and oil in the EU would on average double if external costs to environment and health were included. The result is that electricity generated with renewable energy sources cannot compete on a free market with the conventional one. Consequently, it appears correct to conclude that in order to develop positively, renewable generated electricity requires two essential elements: (i) a price support mechanism that enables renewables producers to enter the market and make a reasonable profit

and (ii) a stable regulatory environment such that investors can enter the market without concern that the price support mechanism will be modified in a unprofitable way.

- Infrastructure. Renewable generators have a number of important challenges that need to be addressed like planning or grid connection issues. The future of RES-E will most likely depend on a combination of prices and political support. Ending distortion by removing subsidies for conventional generation and internalising external costs would go a long way. The problem of external costs could be corrected within the EU e.g. by a carbon tax, at least with regard to fossil fuels. According to APPA (the Spanish Association of Renewable Independent Producers) the external costs of conventional electricity generating sources should be considered an essential element of reference in order to quantify the compensation that must be received by small hydropower electricity in terms of compensation for its environmental and social benefits

Member States have been supporting RES in one or more ways, via Research and Development (R&D), tax reductions/exemptions, guaranteed prices, investment subsidies and the like. The Commission itself has been supporting for over a decade R&D in the field of renewables in the scope of the different Framework Programmes for Research and Development (FPs), six up to now. Nevertheless, thanks to the White Paper and specially RES-E Directive, policy instruments to encourage investment in the production of electricity from RES have been developed in the EU. It is clear that without a tariff's framework that could guarantee the predictability of the investment's remuneration RES-E technologies, shall not achieve the targets indicated in the legislative framework. The RES-E directive defines renewable energy sources as non-fossil energy sources - the original proposal limited hydropower to plants up to 10 MW of installed capacity, but this provision was eliminated in the final draft. Some MS, like Spain, has a feed in tariff for the electricity generated in plants with an installed power from 10 to 50 MW, although the premium decreases with the increase of capacity. Other MS increase the support to the smaller plants by decreasing the value of the premium when production increases. An example is Austria, where the first GWh generated on a new plant is paid at 5.96 cts €, the next 3 GWh at cts € 4.58 and once exceeded the 24 GWh at 3.31 cts €. A complete detailed picture of the tariffs applicable for small hydropower in the EU is given in chapter 8. The EC Directive on common rules for the internal market in electricity also underlines the priority of generation installations using renewable energy sources.

The policy instruments that are in place in the different Member States are all based on two main principles. As figure A.2 shows, the instruments either affect the supply or the demand of renewable electricity, and the focus either on the production of electricity or on the installed capacity of renewable electricity plants.

Within this categorisation, there are basically three main instruments to promote renewable electricity. These instruments are (i) feed-in tariffs, (ii) quota obligations in combination with a green certificate system and (iii) tendering/bidding schemes. Besides the three main instruments there are complementary mechanisms possible, like investment subsidies and fiscal measures.

At the time the RES-E Directive was drafted, the Commission was favourable to adopt the tendering scheme, made popular at that time by the UK NFFO programme but in the final proposal it decided to leave free the choice of support to the Member States. Therefore the Directive does not indicate which set of policy instruments would be favourable. As result, MS continue to develop their own national mix of policy instruments to stimulate renewable electricity.

Generation based (kWh)	
Supply side	Demand side
Feed-in tariffs	Quota obligations /
Fiscal measures	Green certificates
Bidding systems	(Fiscal measures)
(Subsidies)	(Quota obligations)
Investment subsidies	(Quota obligations)
(Fiscal measures)	(Quota obligations)
Capacity based (kW)	

Source: Renewable electricity policies in Europe. Country fact sheets 2003, ECN

**Figure A.2: RES support policy instruments**

- Investment Subsidies:** Authorities offer subsidies on investment for RES-E technologies, in general in terms of % of the Total Investment. This type of support can help to overcome the barrier of a high initial investment and it is commonly used to stimulate investments in less economical renewable energy technologies.
- Feed-in Tariffs:** Operating currently in several EU Member States, (notably Germany and Spain), they are characterised by a specific price being set for RES-E that must be paid by electricity companies, usually distributors, to domestic producers of RES-E. In a variant of the system the government sets a fixed-premium paid above the normal or spot electricity price, to RES-E generators. The fixed price or fixed premium may be revised by the government to reflect falling costs of the technology.
- Quota Obligation Systems and Green Certificates:** Quota obligations are used to impose a minimum production or consumption of electricity from RES. The government sets the framework within which the market has to produce, sell or distribute a certain amount of energy from renewable sources. The obligation is imposed on consumption or production. The quota can usually be traded between companies to avoid market distortions. A Tradable Green Certificate (TGC) is needed for this system. Operating notably in Ireland and The Netherlands, and foreseen for introduction in Denmark and Flanders, the producers sell electricity in the open market, but at the same time receive a “Green Certificate” per MWh produced, which is traded separately from the physical commodity. The value of the TGC comes as the result of the obligation, placed on all consumers to purchase a certain amount of green certificates from RES-E producers according to a fixed percentage, or quota, of their total electricity consumption/production. Since consumers wish to buy these certificates as cheaply as possible, a secondary market of certificates develops where RES producers compete with one-another for the sale of the green certificates.

- **Tendering schemes and bidding systems:** Historically operating in the United Kingdom under the NFFO agreements but no longer in place, prospective RES-E generators submit competitive bids for fixed-price contracts offered by authorities. The system is combined either with feed-in tariffs or TGCs. In UK, where this system operated with some technologies, the TGCs are known as ROCs (Renewable Obligation Certificates). Bidding procedures can be used to select beneficiaries for investment support or production support or for other limited rights. Potential investors or producers have to compete through a competitive bidding system. The criteria for the evaluation of the bids are set before each bidding round. The government decides on the desired level of electricity from each of the RES, their growth rate over time and the level of long-term price security offered to producers over time. The bidding is accompanied by an obligation on the part of electricity providers to purchase a certain amount of electricity from renewable sources at a premium price. The difference between the premium and market price is reimbursed to the electricity consumption. In each bidding round the most cost-effective offers will be selected to receive the subsidy. The mechanism therefore leads to the lowest cost option.
- **Fiscal measures:** Some MS like Austria, Belgium, Denmark or Portugal support renewable electricity by means of fiscal system. These schemes may take different forms, which range from rebates on general energy taxes, rebates from special emission taxes, proposals for lower VAT rates, tax exemption for green funds to fiscal attractive depreciation schemes, which must be in line with the Community guidelines on State aid for environmental protection.

Concerning SHP, table A.2, elaborated recently by ESHA, shows the support systems adopted by the different Member States and currently in force. Prices generated by these support systems or buy-back prices are detailed in chapter 8.

No significant changes will take place in the medium term in the Member States, but there is still uncertainty about that possibility. In Denmark, one of the original supporters of the feed-in tariffs for wind energy, the introduction of a TGC system has been announced and postponed several times, and still there is a large uncertainty on the planned introduction in 2004. In Ireland, the government has announced the intention to release a consultation document in the first quarter of 2003 with the objective to set new targets for the RES-E technologies in the year 2010, and to examine alternative measures for supporting them. In Spain the feed-in tariffs will probably remain for years although investors demand clearer rules in the determination of the future premium prices. In Austria after the negative experience with the tradable green certificate system for small hydro it is unlikely that the feed-in tariffs support scheme will change now that a certain harmonization at state level has been achieved. In Germany, the Federal Environment Ministry published an amendment to the Renewable Energy Law (in 2003) with the request for comments. The proposal still supports the feed in tariff scheme as the preferred instrument to reach the 2010 target, but introduces more differentiated tariffs, some lower and some higher than those of the present law. No significant changes are expected in the other countries. RES-E producers try to limit the price uncertainty, in the feed tariff system, requesting the authorities to issue transparent rules that determine the premium for the next years.

The RES-E Directive – Art 4, paragraph 2 -, puts an obligation on the Commission to present, not later than 27 October 2005, a well-documented report on experience gained with the application and coexistence of the different mechanisms of support. The report shall assess the success of the support systems in promoting the consumption of electricity produced from renewable energy. This report shall, if necessary, be accompanied by a proposal for a Community framework with regard to support schemes for electricity produced from renewable energy sources. Any such proposal must include a transitional period of at least seven years, this means that no mandatory unified system will be in force until 2012.



**Table A.2: SHP current support systems used in EU Members States**

<b>Member State</b>	<b>Compensation Scheme</b>
Belgium	Wallonia: Green certificates since 1 <sup>st</sup> October 2002 Flanders: Green certificates since 1 <sup>st</sup> January 2003
Denmark	Transition period from fixed price to green certificates.
Germany	Feed-in tariff
Greece	Feed-in tariff
Spain	Fixed price (feed-in tariff) and premium payment adjusted annually by government.
France	Feed-in tariffs applicable only to renewable plants up to 12 MW. Price paid to SHP plants depends on their construction date. Winter tariff for SHP plants commissioned after 2001 is guaranteed for 20 years.
Ireland	Public tender: Alternative Energy Requirement (AER) competitions. The Irish Government launched in February 2003 the AER VI.
Italy	Quota + tradable green certificates: The quota should increase by 0.3% each year starting from 2005. The grid authority fixes a cap (upper) price for green certificates every year. Certificates are issued only for the first eight years of operation.
Luxembourg	Feed-in tariff. Premium is guaranteed for 10 years.
Netherlands	New support system as from 1 <sup>st</sup> July 2003. Wholesale electricity market and feed-in premium. Hydropower does not receive green certificates.
Austria	Feed-in tariff: a) Old plants: Plants which obtained planning permission before January 1 <sup>st</sup> 2003, including all those currently operating, are entitled to receive the guaranteed feed-in tariff for the first 10 years of operation. b) New plants: Plants obtaining all planning permissions between January 1 <sup>st</sup> 2003 and December 31 <sup>st</sup> 2005 and which start generating by the end of 2006 are entitled to receive the feed-in tariff for the first 13 years of operation.
Portugal	Feed-in tariff
Finland	Nordpool market plus premium
Sweden	Green certificates: This system was started May 1 2003.
United Kingdom	Market price (energy market – NETA) and Renewable Energy Obligation Certificates – ROC's (only available for Hydropower up to 20MW when they have been built since 1990 or if built before 1990 have been refurbished with new turbine runners and control equipment. Also hydro plants commissioned since 2000 are also eligible for ROC's

### **A.3 BARRIERS**

One major barrier to the further development of RES electricity in the EU is the administrative and planning procedures that potential generators must meet. This has been highlighted by ESHA on behalf of a large number of representative organisations responsible for the small hydro producers. It should be noted that these rules, often developed for both large generation projects and small RES projects alike, place a significant burden on RES producers given their smaller size, both overall and in terms of average generation site.

The planning procedures vary significantly among Member States, regions and projects. Articles 4-6 of the RES-E Directive provide the basic rules in this respect, notably that where an authorisation procedure is followed, the rules must be objective and non-discriminatory. In the BlueAge study carried out on behalf of ESHA and partially funded by the Commission, the length of the authoritative procedures was estimated from 12 weeks in Scotland to two years in Italy and 4 years in Spain. But what is more significant is that in almost every MS of the EU only a few dozens of permissions have been granted recently. Without authorizations no development is possible and therefore support schemes favouring competitive prices become useless, not only to promote SHP but also to achieve 2010 objectives.

RES-E Directive suggests that an effort is necessary to make progress in this area and propose to require all Member States:

- To review the existing measures, planning and administrative, that potential RES producers must meet, to determine which action, if any, can be taken to reduce the regulatory barriers to increasing RES production such as:
  - ⇒ The setting up of a single reception point for authorisation applications,
  - ⇒ Ensuring co-ordination between the different administrative bodies involved and the establishment of reasonable deadlines,
  - ⇒ The establishment of a “fast-track” planning procedure for RES producers,
  - ⇒ Where applicable, the possibility of establishing mechanisms under which the absence of a decision by the competent bodies on an application for authorisation within a certain period of time automatically results in an authorisation,
  - ⇒ The production of specific planning guidelines for RES projects,
  - ⇒ The identification, at national, regional or local level, of sites suitable for establishing,
  - ⇒ New capacity for generating RES electricity,
  - ⇒ The introduction of training programmes for the personnel responsible for the authorisation procedures.
- To publish a report in this respect, outlining the conclusions reached as to what action, will be taken, no later than two years following the entry into force of the Directive. The Commission

would, on the basis of the Member States reports, present a report on the experience of Member States, highlighting best practice.

Directive 2003/54/EC concerning common rules for the internal market in electricity suggest also some measures on this respect. For example:

- In the preamble of the Directive it is mentioned that:
  - ⇒ To avoid imposing a disproportionate financial and administrative burden on small distribution companies, Member States should be able, where necessary, to exempt such companies from the legal distribution unbundling requirements.
  - ⇒ Authorisation procedures should not lead to an administrative burden disproportionate to the size and potential impact of electricity producers.
  - ⇒ Nearly all Member States have chosen to ensure competition in the electricity generation market through a transparent authorisation procedure. However, Member States should ensure the possibility to contribute to security of supply through the launching of a tendering procedure or an equivalent procedure in the event that sufficient electricity generation capacity is not built on the basis of the authorisation procedure. Member States should have the possibility, in the interests of environmental protection and the promotion of infant new technologies, of tendering for new capacity on the basis of published criteria. New capacity includes inter alia renewables and combined heat and power (CHP).
- Article 3 about public service obligations and customer protection mentions that:
  - ⇒ Member States shall ensure, on the basis of their institutional organisation and with due regard to the principle of subsidiarity, that electricity undertakings are operated in accordance with the principles of this Directive with a view to achieving a competitive, secure and environmentally sustainable market in electricity, and shall not discriminate between these undertakings as regards either rights or obligations.
  - ⇒ Having full regard to the relevant provisions of the Treaty, in particular Article 86 thereof, Member States may impose on undertakings operating in the electricity sector, in the general economic interest, public service obligations which may relate to security, including security of supply, regularity, quality and price of supplies and environmental protection, including energy efficiency and climate protection. Such obligations shall be clearly defined, transparent, non discriminatory, verifiable and shall guarantee equality of access for EU electricity companies to national consumers. In relation to security of supply, energy efficiency/demand-side management and for the fulfilment of environmental goals, as referred to in this paragraph, Member States may introduce the implementation of long term planning, taking into account the possibility of third parties seeking access to the system.
  - ⇒ Member States shall ensure that electricity suppliers specify in or with the bills and in promotional materials made available to final customers the contribution of each energy source to the overall fuel mix of the supplier over the preceding year and at least the reference to existing reference sources, such as web-pages, where information on the environmental impact, in terms of at least emissions of CO<sub>2</sub> and the radioactive waste resulting from the electricity produced by the overall fuel mix of the supplier over the preceding year is publicly available.

- ⇒ Member States shall implement appropriate measures to achieve the objectives of social and economic cohesion, environmental protection, which may include energy efficiency/demand-side management, measures and means to combat climate change, and security of supply. Such measures may include, in particular, the provision of adequate economic incentives, using, where appropriate, all existing national and Community tools, for the maintenance and construction of the necessary network infrastructure, including interconnection capacity.
- ⇒ Member States shall, upon implementation of this Directive, inform the Commission of all measures adopted to fulfil universal service and public service obligations, including consumer protection and environmental protection, and their possible effect on national and international competition, whether or not such measures require a derogation from this Directive. They shall inform the Commission subsequently every two years of any changes to such measures, whether or not they require derogation from this Directive.
- Article 6 on authorisation procedure for new capacity underlines that:
  - ⇒ The authorisation procedures and criteria shall be made public. Applicants shall be informed of the reasons for any refusal to grant an authorisation. The reasons must be objective, non discriminatory, well founded and duly substantiated. Appeal procedures shall be made available to the applicant.
- Article 7 on tendering for new capacity mentions that:
  - ⇒ Member States may ensure the possibility, in the interests of environmental protection and the promotion of infant new technologies, of tendering for new capacity on the basis of published criteria. This tender may relate to new capacity or energy efficiency/demand-side management measures. A tendering procedure can, however, only be launched if on the basis of the authorisation procedure the generating capacity being built or the measures being taken are not sufficient to achieve these objectives.

### THE ISSUE OF GRID CONNECTION AND ACCESS TO THE NETWORK

With the exception of isolated schemes, the plant cannot be operated without connection to the grid. Specifications for connection to the grid can also be a deterrent to the development of SHP and/or affect the viability of a scheme. Utilities that require unreasonable or unnecessary specifications or conditions (locating the connection point far away from the plant) strongly affect the feasibility of a scheme. In any case, utilities should guarantee a certain quality in their service, therefore asking for certain requirements from the independent producer to be connected to the grid.

The RES-E Directive in Art 7 states that “without prejudice to the maintenance of the reliability and safety of the grid, Member States shall take the necessary measures to ensure that transmission system operators and distribution system operators in their territory guarantee the transmission and distribution of electricity produced from renewable energy sources. This is of particular importance for RES-E being often small projects and, thus economically vulnerable towards interruptions in feeding in their electricity. They may also provide for priority access to the grid system of electricity produced from renewable energy sources. When dispatching generating installations, transmission system operators shall give priority to generating

installations using renewable energy sources insofar as the operation of the national electricity system permits". The Directive demands that Member States require the transmission system operators and distribution system operators to set up and publish their standard rules relating to the bearing of costs of technical adaptations, such as grid connections and grid reinforcements, which are necessary in order to integrate new producers feeding electricity produced from renewable energy sources into the interconnected grid and even to bear in full or in part the cost of the grid connections and grid reinforcements. The question of who has to pay for these grid-strengthening investments may affect the rate of uptake of RES-E in general. It should be noted that the Electricity Directive in Article 7(2) provides that Member States must ensure that technical rules and operational requirements concerning the connection of generators to the transmission grid are developed in an objective and non-discriminatory manner and are published.

Directive 2003/54/EC concerning common rules for the internal market in electricity is more precise and strict on this respect. For example, in the preamble when talking about the benefits of the internal market it is clearly stated that: "However important, shortcomings and possibilities for improving the functioning of the market remain, notably concrete provisions are needed to ensure a level playing field in generation and to reduce the risks of market dominance and predatory behaviour, ensuring non-discriminatory transmission and distribution tariffs, through access to the network on the basis of tariffs published prior to their entry into force, and ensuring that the rights of small and vulnerable customers are protected and that information on energy sources for electricity generation is disclosed, as well as reference to sources, where available, giving information on their environmental impact. The main obstacles in arriving at a fully operational and competitive internal market relate amongst other things to issues of access to the network, tarification issues and different degrees of market opening between Member States. For competition to function, network access must be non-discriminatory, transparent and fairly priced. In order to complete the internal electricity market, non-discriminatory access to the network of the transmission or the distribution system operator is of paramount importance. A transmission or distribution system operator may comprise one or more undertakings."

It also underlines that: "The maintenance and construction of the necessary network infrastructure, including interconnection capacity and decentralised electricity generation, are important elements in ensuring a stable electricity supply. The respect of the public service requirements is a fundamental requirement of this Directive, and it is important that common minimum standards, respected by all Member States, are specified in this Directive, which take into account the objectives of common protection, security of supply, environmental protection and equivalent levels of competition in all Member States. It is important that the public service requirements can be interpreted on a national basis, taking into account national circumstances and subject to the respect of Community law."

Several articles in the directive deal directly with the access to the network, access to the grid and new capacity:

- Article 5 on technical rules specifies that "Member States shall ensure that technical safety criteria are defined and that technical rules establishing the minimum technical design and operational requirements for the connection to the system of generating installations, distribution systems, directly connected consumers' equipment, interconnector circuits and direct lines are developed and made public. These technical rules shall ensure the interoperability of systems and shall be objective and non discriminatory. They shall be notified to the Commission in accordance with Article 8 of Directive 98/34/EC of the European Parliament and of the Council of 22 June 1998 laying down a procedure for the

provision of information in the field of technical standards and regulations and of rules on Information Society Services”.

- Article 6 on authorisation procedure for new capacity underlines that “Member States shall lay down the criteria for the grant of authorisations for the construction of generating capacity in their territory. These criteria may relate to, among others: protection of public health and safety, protection of the environment and energy efficiency”.
- Article 14 on tasks of the Distribution System Operator is very explicit as regards RES, “A Member State may require the distribution system operator, when dispatching generating installations, to give priority to generating installations using renewable energy sources or waste or producing combined heat and power. Where distribution system operators are responsible for balancing the electricity distribution system, rules adopted by them for that purpose shall be objective, transparent and non discriminatory, including rules for the charging of system users of their networks for energy imbalance.”

Commission shall monitor and review the application of this Directive and submit an overall progress report to the European Parliament and the Council before the end of the first year following the entry into force of the Directive (this Directive is already in force since August 2003 and should be transpose into national law by 1 July 2004 at the latest), and thereafter on an annual basis. The report shall cover at least, among other things, the experience gained and progress made in creating a complete and fully operational internal market in electricity and the obstacles that remain in this respect, including aspects of market dominance, concentration in the market, predatory or anti-competitive behaviour and the effect of this in terms of market distortion. The Commission shall, no later than 1 January 2006, forward to the European Parliament and Council, a detailed report outlining progress in creating the internal electricity market. The report shall, in particular, consider the *existence of non-discriminatory network access*.

#### **A.4 EU CURRENT INTERNAL MARKET**

The latest report from the European Commission about the advances and success of the implementation of the internal electricity market in the EU shows that the situation is as follows:

- Implementation of the Electricity Directive. Although progress has been made in the electricity sector since 2001 in terms of general functioning of the market, there are still some areas causing particular difficulties:
  - ⇒ Differential rates of market opening are reducing the scope of benefits to customers from competition.
  - ⇒ Disparities in access tariffs between network operators, which due to the lack of transparency may form a barrier to competition.
  - ⇒ High level of market power among existing generating companies which impedes new entrants.
  - ⇒ Insufficient interconnection infrastructure between Member States.
- Results of market opening for customers. The two immediate consequences of market opening are a normal decrease of electricity prices and a free opportunity to switch and negotiate

supplier. Nevertheless, the trend of the electricity prices since 1999 is not remarkably downwards in the EU. The trend varies depending on the country with some MS experiencing rising prices and the falling effect is more remarkable in large consumers (industry) than in smaller ones (households). As far as concerns switching and renegotiating suppliers, in almost all MS, the majority of large eligible customers have taken the opportunity to explore alternative suppliers. For smaller customers it is of particular note that customers switching in Germany and Austria have increased.

- Public service issues. Member States are aware of the need to ensure security of supply, to deliver high levels of services to all customers and to defend the Community’s environmental objectives. Key issues being addressed in MS include, among others, measures to increase the share of renewable energy.
- Access to networks. Two issues affect the effective access to the network:

⇒ Network Tariffs: There is a wide variation between Member States in terms of the number of companies operating the different parts of transmission and distribution network. This is, in most cases, a legacy of how electricity supply was organised prior to market opening. In some cases such as in France, Ireland and Greece, there is a single national company that owns both the transmission and most or all of the distribution system at national level. In other cases, like Germany and Austria, transmission systems are operated on a regional basis, with distribution based on numerous individual municipal areas. Other Member States fall in between these two extremes in terms of the number of system operators.

**Table A.3: Network access in the EU, electricity**

TOTAL NETWORK TARIFFS	Number of transmission companies	Number of distribution companies	Medium Voltage		Low voltage	
			Estimated average charge (€/MWh)	Approx. range high-low (€/MWh)	Estimated average charge (€/MWh)	Approx. range high-low (€/MWh)
Austria	3	155	20	15-25	65	50-80
Belgium	1	33	15	n.a.		
Denmark	2	77	15	n.a.	25	unknown
Finland	1	100	15	10-20	35	unknown
France	1	172	15	n.a.	50	n.a.
Germany	4	880	25	15-45	55	40-75
Greece	1	1	15	n.a.		
Ireland	1	1	10	n.a.	40	n.a.
Italy	1	219	10	n.a.		
Luxembourg	-	15	20	n.a.		
Neth	1	18	10	unknown	35	unknown
Portugal	1	3	15	n.a.		
Spain	1	297	15	n.a.	45	n.a.
Sweden	1	248	10	5-15	40	20-60
UK	4	15	unknown	10-15	40	30-50

Source: Second benchmarking report on the implementation of the internal electricity and gas market. Commission staff working paper, SEC (2003) 448

⇒ Balancing: Another important issue for ensuring fair network access centres on the conditions associated with balancing. Balancing is carried out by the transmission system operator (TSO) who usually charges network users for the service of providing “top-up” or

disposing of “spill” energy. The conditions for balancing are important for new entrants since they often have a smaller portfolio of clients and the risk of imbalance is usually higher. In most Member States the price of balancing electricity is now established on the basis of market principles, with the methodology used approved by the regulator. In other cases the prices are subject to direct regulation. However, in Belgium and Luxembourg it would appear that the TSO controls balancing without any regulatory intervention or a market process and there is some evidence that this makes conditions for new entrants unfavourable.

- Security of supply. The introduction of competition in the electricity and gas markets must be arranged so that customers can rely on a close to continuous and reliable supply. This means that there must be sufficient production and transportation capacity to deal with the varying levels of demand during the year and in different conditions. For electricity, the security of supply position is usually monitored by the transmission system operators (TSO) in the Member States concerned as a consequence of their function in balancing supply and demand in the network. TSOs, in any case, need to be aware of trends in generation and demand in order to plan for appropriate investments in the network. Table A.4 provides data on the reserve generating capacity position for 2002. Normally Member States expect to maintain the level of “remaining capacity” above 5% of available capacity, taking into account the scope for imports.

**Table A.4: Electricity security of supply**

	Security of Supply Position 2002				Measures to Encourage Peak Capacity			
	amount of reserve generating capacity <sup>30</sup>	import capacity (% of peak consumption)	% p.a. increase in peak load	increase in capacity by 2004 (GW)	Market based	Incentives e.g. capacity payments	Obligation on TSO or supplier	Tender by Regulator or TSO
Austria	34%	45%	+2.1%	0.4	x			
Belgium	2%	31%	+2.1%	0.2			x	
Denmark					x			
Finland					unknown			
France	16%	19%	+1.9%	0.4	x			
Germany	5%	15%	+0.5%	0.8	x			
Greece	7%	13%	+3.2%	1.2				(x)
Italy	9%	12%	+3.7%	5.7		(x)		
Ireland	-2%	6%	+3.0%	0.8		x		(x)
Luxembourg	-	100%	+2.8%	0.0	n.a.			
Netherlands	7%	28%	+3.0%	0.7			x	
Portugal	13%	13%	+4.0%	0.5		x		
Spain	16%	7%	+3.1%	4.6		x		
Sweden							x	
UK	12%	3%	+1.0%	5.0	x			
Nordel	1%	5%	+0.8%	6.0				

Source: Second benchmarking report on the implementation of the internal electricity and gas market. Commission staff working paper, SEC (2003) 448

- Environmental objectives. The low capital costs of gas-fired generation and its relative efficiency in fuel use is leading to its widespread adoption throughout the EU. Similarly, competition may also lead to the more rapid retirement of older and less environmentally sound capacity. This has happened in particular in the UK, which reduced emissions considerably



during the 1990s. However, the introduction of competition is also likely to lead to lower energy prices than would otherwise be the case. This is because competition will provide incentives for companies to reduce costs, for example, by closing inefficient plant. This provides a challenge in environmental terms since lower prices in themselves may encourage greater consumption and also reduce the viability of renewable energy, particularly if the external cost of the use of fossil fuels is not recognised. Since Member States have commitments to meet relating to the reduction of greenhouse gas and other emissions, it is important to ensure that market opening is made compatible with these. Table A.5 shows efforts of Member States to manage demand and encourage renewable generation.

**Table A.5: Environmental policy framework**

	VAT rate	energy tax	main RES support mechanism	Net addition to generation 1998-2001 (MW)			
				net new coal/oil	net new gas	net new RES/CHP	other
Austria	20	**	fixed feed in tariff	no information			
Belgium	21	*	quota system (green certs.)	-225	-225	+433	-
Denmark	25	***	quota system (green certs)	-803	+317	-	+32
Finland	22	*	investment subsidies	+270	+160	+307	+220
France	19.6/5.5	*	quota system (tender)	no information			
Germany	16	**	fixed feed in tariff	-166	-101	+3150	+1251
Greece	8	none	fixed feed in tariff plus subsidies	-80	+492	-	-
Ireland	12.5	none	quota system (tender)	0	+310	+1074	+84
Italy	20/10	**	quota system	-	+4880	+1167	-
Lux	6	*	fixed feed in tariff	no information			
Neth	19	***	quota system (green certs)	-	+227	+511	-
Portugal	5	none	fixed feed in tariff	-50	+660	-	-
Spain	16	*	fixed feed in tariff	+341	-	+5942	+1057
Sweden	25	**	quota system (green certs)	-2500	-	+7	-600
UK	17.5/5	*	quota system (tender)	-5228	+5734	+109	-257
<b>Total</b>				<b>-8400</b>	<b>+12500</b>	<b>+12700</b>	<b>+1800</b>

Source: Second benchmarking report on the implementation of the internal electricity and gas market. Commission staff working paper, SEC (2003) 448

The table demonstrates that all Member States have some kind of programme to support renewables and the effectiveness of such policies can be gauged by an examination of the fuel mix of net new capacity added during the years 1998-2001. This shows that remarkable progress is being made with regard to renewables, which comprise of nearly 50% of new capacity being added in Europe. The most important contributors to the increase in renewable energy sources in the period concerned are Germany and Spain. It should also be underlined that many Member States have an active fiscal policy for energy with the aim of increasing the use of renewable energy and reducing consumption. The main leaders in this area are Denmark and the Netherlands. However on this issue of energy taxation it is important to remember that gas and electricity cannot be considered in isolation. Coal and oil are also carbon-intensive fuels and need to be included in a comprehensive energy taxation system. The Council restarted discussions on the Commission’s proposal for a Directive to restructure the taxation of energy [COM (1997) 30] and the adoption of these proposals is also encouraged.

To conclude, table A.6 shows the basic position by MS as at the end of February 2003, indicating the proportion of the market open to competition, the relevant thresholds and information on the regulation of the market and unbundling.

**Table A.6: Electricity internal market situation in the EU**

	<b>Electricity</b>					
	Market opening	size of open market Twh	eligibility threshold	100% in/by	Unbundling transmission	Network access
Austria	100%	52	-	2001	Legal	Reg.
Belgium <sup>7</sup>	52%	40	1/10Gwh	2003/7	Legal	Reg.
Denmark	<b>100%</b>	32	-	2003	Legal	Reg.
Finland	100%	75	-	1997	Ownership	Reg.
France	<b>37%</b>	131	<b>7 Gwh</b>	<b>2007</b>	Management	Reg.
Germany	100%	483	-	1999	Legal <sup>9</sup>	Neg.
Greece	34%	15	1kV	<b>2007</b>	Legal\Mgmt	Reg.
Ireland	<b>56%</b>	8	<b>0.1 Gwh</b>	2005	Legal\Mgmt	Reg.
Italy	<b>70%</b>	191	<b>0.1 Gwh</b>	<b>2007</b>	Own\Legal.	Reg.
Luxembourg	57%	3	20 gwh	<b>2007</b>	Management	Reg.
Netherlands	63%	62	3*80 A	2003	Ownership	Reg.
Portugal	45%	17	1kV	<b>2004</b>	Legal	Reg.
Spain	<b>100%</b>	188	-	2003	Ownership	Reg.
Sweden	100%	129	-	1998	Ownership	Reg.
UK	100% <sup>11</sup>	330	-	1998	Ownership	Reg.

Source: Second benchmarking report on the implementation of the internal electricity and gas market. Commission staff working paper, SEC (2003) 448.

## **BIBLIOGRAPHY**

1. Working paper of the European Commission “ Electricity from renewable sources and the internal electricity market.
2. ECN Report “Renewable electricity policies in Europe. Country fact sheets 2003”.
3. Directive 2003/54/EC concerning common rules for the internal market in electricity and repealing Directive 96/92/EC
4. Commission staff working paper “Second benchmarking report on the implementation of the internal electricity and gas market. SEC(2003) 448.
5. Directive 2001/77/EC on the promotion of electricity produced from renewable energy sources in the internal electricity market.

---

<sup>1</sup> By Francis Armand (ADEME), Gema San Bruno (ESHA), Maria Laguna (ESHA), and Celso Penche (ESHA)

<sup>2</sup> A part of the information presented in this chapter is taken from the French guidebook “Guide pour le montage de projets de petite hydroélectricité” ADEME – Géokos mai 2003.

<sup>3</sup> ESHA - Presentation by Georges Babalis at Hidroenergia 97

<sup>4</sup> See also TNSHP – Environmental group – Reserved flow – Short critical review of the methods of calculation at [Hwww.esha.be](http://www.esha.be)

<sup>5</sup> A part of the following examples have been supplied by countries working in the European contract “SPLASH” (Spatial plans and Local Arrangement for Small Hydro): Ireland, Greece, and Portugal. Let them be thanked.

<sup>6</sup> A part of the information presented in this chapter is taken from the French guidebook “Guide pour le montage de projets de petite hydroélectricité” ADEME – Géokos mai 2003.

<sup>7</sup> Commission staff working paper, “Second benchmarking report on the implementation of the internal electricity and gas market”. SEC(2003) 448.

## GLOSSARY

**Alternating current (AC):**

Electric current that reverses its polarity periodically (in contrast to direct current). In Europe the standard cycle frequency is 50 Hz, in N. and S. America 60 Hz.

**Anadromous fish:**

Fish (e.g. salmon), which ascend rivers from the sea at certain seasons to spawn.

**Average Daily Flow:**

The average daily quantity of water passing a specified gauging station.

**Base flow:**

That part of the discharge of a river contributed by groundwater flowing slowly through the soil and emerging into the river through the banks and bed.

**BFI baseflow index:**

The proportion of run-off that baseflow contributes.

**Butterfly Valve:**

A disc type water control valve, wholly enclosed in a circular pipe that may be opened and closed by an external lever. Often operated by a hydraulic system.

**Capacitor:**

A dielectric device, which momentarily absorbs and stores electric energy.

**Catchment Area:**

The whole of the land and water surface area contributing to the discharge at a particular point on a watercourse.

**Cavitation:**

A hydraulic phenomenon whereby liquid gasifies at low pressure and the vapour bubbles form and collapse virtually instantaneously causing hydraulic shock to the containing structure. This can lead to severe physical damage in some cases.

**Compensation flow:**

The minimum flow legally required to be released to the watercourse below an intake, dam or weir, to ensure adequate flow downstream for environmental, abstraction or fisheries purposes.

**Demand (Electric):**

The instantaneous requirement for power on an electric system (kW or MW). Demand Charge that portion of the charge for electric supply based upon the customer's demand characteristics.

**Direct Current (DC):**

Electricity that flows continuously in one direction sd contrasted with alternating current.

**Draft tube:**

A tube full of water extending from below the turbine to below the minimum water tailrace level.

**Energy:**

Work, measured in Newton metres or Joules. The electrical energy term generally used is kilowatt-hours (kWh) and represents power (kilowatts) operating for some period of time (hours)

1 kWh =  $3.6 \times 10^3$  Joules.

**Evapotranspiration:**

The combined effect of evaporation and transpiration.

**FDC:**

Flow duration curve: a graph of discharges against v. the percentage of time (of the period of record) during which particular magnitudes of discharge were equalled or exceeded.

**Fish Ladder:**

A structure consisting e.g. of a series of overflow weirs which are arranged in steps that rise about 30 cm in 3 50 4 m horizontally, and serve as a means for allowing migrant fish to travel upstream past a dam or weir.

**Flashboards:**

One or more tier of boards supported by vertical pins embedded in sockets in the spillway crest.

**Flow duration curve:**

See FDC

**Forebay:**

A pond or basin of enlarged water. Surface and depth, usually at the end of a canal or leat, from whence a penstock leads to a powerhouse.

**Freeboard:**

In a canal, the height of the bank above the water level.

**Gabions:**

Large, usually rectangular, boxes of metal mesh filled with stones or broken rock.

**Gate Valve:**

A vertical gate type water control valve, requiring more space than an equivalent diameter butterfly valve, which can be opened either mechanically or hydraulically.

**Geotextiles:**

Synthetic materials (e.g. polypropylene, nylon) woven into rolls or mats which are laid as permanent but permeable foundation blankets under stone, rock or other revetment materials.

**Governor:**

A controlling device that adjust the flow of water through the turbine following the output signal of a certain sensor (turbine speed, intake water level etc.).

**Gravitational constant g:**

Acceleration due to gravity, approximately 9.81 m/s<sup>2</sup>.

**HDPE:**

High-density polyethylene

**Head, gross:**

The difference in level between the water surfaces at intake and tailrace of a hydroelectric system

**Head, net:**

The head available for power generation at the turbine, incorporating all head losses in screens, intakes, pipes, valves, draft tube and tailrace.

**Headpond:**

See “forebay”.

**Hertz (Hz):**

Cycles per second, as applied to ac generation.

**Hydraulic gradient:**

The hydraulic pressure profile along a pipe or conduit, which is flowing full.

**Infiltration:**

The process whereby rainfall penetrates through the land surface to form soil moisture or groundwater.

**Installed capacity:**

The total maximum capacity of the generating units in a hydropower plant.

**Isovels:**

Lines of equal velocity drawn on cross-sections of watercourses.

**Leat:**

An open channel that conveys water at a shallow gradient from a river intake to point where sufficient head has been gained for a turbine to be installed. (Also sometimes called GOIT or CONTOUR CANAL).

**Load (Electrical):**

The power capacity supplied by a particular plant on an electric system.

**Load factor:**

Is defined as the ratio annual energy output kWh/max power output x 8760 hours

**Outage:**

The period in which a generating unit, transmission line, or other facility, is out of service.

**Output:**

The amount of power (or energy, depending on definition) delivered by a piece of equipment, station or system.

**(In) Parallel:**

The term used to signify that a generating unit is working in connection with the mains supply, and hence operating synchronously at the same frequency.

**Overspeed:**

The speed of the runner when, under design conditions, all external loads are removed

**P.E.:**

Polyethylene

**Peak Load:**

The electric load at the time of maximum demand.

**Peaking Plant:**

A power plant, which generates principally during the maximum demand periods of an electrical supply network.

**Penstock:**

A pipe (usually of steel, concrete or cast iron and occasionally plastic) that conveys water under pressure from the forebay to the turbine.

**Percolation:**

The movement of water downwards through the soil particles to the phreatic surface (surface of saturation within the soil; also called the groundwater level).

**Power:**

The capacity to perform work. Measured in joules/sec or watts ( $1\text{MW} = 1\text{ j/s}$ ). Electrical power is measured in kW.

**Power factor:**

The ratio of the amount of power, measured in kilowatts (kW) to the apparent power measured in kilovolt-amperes (kVA).

**Rating curve:**

The correlation between stage and discharge.

**Reynolds Number:**

A dimensionless parameter used in pipe friction calculations (interalia), and derived from pipe diameter, liquid velocity and kinematic viscosity.

**Rip-rap:**

Stone, broken rock or concrete block revetment materials placed randomly in layers as protection from erosion.

**Runoff:**

The rainfall, which actually does enter the stream as either surface or subsurface flow.

**Run-of-river scheme:**

Plants where water is used at a rate no greater than that with which it “runs” down the river.

**SOIL:**

A parameter of permeability

**Stage (of a river):**

The elevation of water surface

**Supercritical flow:**

Rapid flow who is unaffected by conditions downstream

**Synchronous speed:**

The rotational speed of the generator such that the frequency of the alternating current is precisely the same as that of the system being supplied.

**Tailrace:**

The discharge channel from a turbine before joining the main river channel.

**Trashrack:**

An structure made up of one or more panels, each generally fabricated of a series of evenly spaced parallel metal bars.

**Utilisation Factor:**

The ratio found by dividing the number of hours per year (or other unit time) that a plant is generating, by the number of hours in a year (or in the other unit time). (This is not the same as load factor).

**Weighted average rainfall:**

The average rainfall over an entire catchment that allows for the variation in rainfall between the wetter and drier areas.

**Weir:**

A low dam, which is designed to provide sufficient upstream depth for, a water intake while allowing water to pass over its crest.